



Radial Leaded Multilayer Ceramic Capacitors For Automotive Applications Class 1 and Class 2, 50 V_{DC}, 100 V_{DC}, 200 V_{DC}



FEATURES

- AEC-Q200 qualified with PPAP available
- High reliability MLCC insert with wet build process
- High operating temperature up to 160 °C
- High capacitance with small size
- Radial mounting style
- Crimp and straight leadstyles
- Parts compliant with ELV directive
- Material categorization:
for definitions of compliance please see www.vishay.com/doc?99912



APPLICATIONS

- Automotive

| QUICK REFERENCE DATA | | | | | | |
|----------------------------|--------|--------|------|-----------|---------|---------|
| DESCRIPTION | VALUE | | | | | |
| Ceramic class | 1 | | | 2 | | |
| Ceramic dielectric | C0G | | | X7R | | |
| Voltage (V _{DC}) | 50 | 100 | 200 | 50 | 100 | 200 |
| Min. capacitance (pF) | 100 | 100 | 100 | 330 | 330 | 330 |
| Max. capacitance (pF) | 12 000 | 12 000 | 8200 | 1 000 000 | 470 000 | 180 000 |
| Mounting | Radial | | | | | |

MARKING

Marking indicates capacitance value and tolerance in accordance with "EIA 198".

OPERATING TEMPERATURE RANGE

-55 °C to +160 °C (50 % rated voltage above 150 °C)

TEMPERATURE CHARACTERISTICS

Class 1: C0G

Class 2: X7R

SECTIONAL SPECIFICATIONS

Climatic category (acc. to EN 60058-1)

Class 1 and 2: 55/125/21

APPROVALS

EIA 198
IEC 60384-9
AEC-Q200

DESIGN

- The capacitors consist of a high reliability MLCC
- The lead wires are 0.5 mm / 0.6 mm and are made of 100 % tinned copper clad steel wire (nickel wires for welding are available on request)
- The capacitors may be supplied with straight or kinked leads having a lead spacing of 2.5 mm and 5.0 mm
- Coating is made of black colored flame retardant epoxy resin in accordance with UL 94 V-0

CAPACITANCE RANGE

100 pF to 1 µF

TOLERANCE ON CAPACITANCE

± 5 %, ± 10 %, ± 20 %

RATED VOLTAGE

50 V_{DC}, 100 V_{DC}, 200 V_{DC}

TEST VOLTAGE

- 50 V_{DC} and 100 V_{DC}: 250 % of rated voltage
- 200 V_{DC}: 200 % of rated voltage

INSULATION RESISTANCE

100 GΩ or 1000 ΩF whichever is less at rated voltage within 2 min of charging.

DISSIPATION FACTOR

Class 1: 0.1 % max.
(at 1 MHz, 1 V where C ≤ 1000 pF;
at 1 kHz, 1 V where C > 1000 pF)

Class 2: 2.5 % max.
(at 1 kHz, 1 V)

LEAD CONFIGURATION AND DIMENSIONS in millimeters

| SIZE CODE | Wb _{MAX.} | H _{MAX.} | T _{MAX.} | Lead Diameter | MAXIMUM SEATING HEIGHT (SH) | | | |
|-----------|--------------------|-------------------|-------------------|---------------|-----------------------------|-----|-----|-----|
| | | | | | L2 | H5 | K2 | K5 |
| 15 | 3.0 - 3.8 | 2.0 - 3.8 | 1.6 - 2.6 | 0.50 ± 0.05 | 1.6 | 2.6 | 3.5 | 3.5 |
| 20 | 4.3 - 5.1 | 2.5 - 5.1 | 1.9 - 3.2 | 0.60 ± 0.05 | 1.6 | 2.6 | 3.5 | 3.5 |

Notes

- Bulk packed types have a standard lead length L = 30 mm ± 5 mm
- L2 and H5 are preferred styles

MARKING

| SIZE 15 | | SIZE 20 | |
|----------|----------|----------|----------|
| Side One | Side Two | Side One | Side Two |
| | | | |

Notes

- Two significant digits followed by one digit for the multiplier as given following: 1 = * 10, 2 = * 100, 3 = * 1000, 4 = * 10 000, 5 = * 100 000
- The tolerance codes are J = 5 %, K = 10 %, M = 20 %

ORDERING CODE INFORMATION

| Product Type | Capacitance (pF) | Capacitance Tolerance | Size Code | T.C. Code | Rated Voltage | Lead Diameter | Packaging / Lead Length | Lead Style | Lead Spacing | AEC-Q200 qualified |
|------------------------|--|---------------------------------------|------------------------------------|------------------------------------|--|-----------------------|---|---|--------------------------|---|
| K = radial leaded MLCC | The first two digits are the significant figures of capacitance and the last digit is a multiplier as follows: 1 = * 10 2 = * 100 3 = * 1000 4 = * 10 000 5 = * 100 000 | J = ± 5 % K = ± 10 % M = ± 20 % | Please refer to relevant datasheet | Please refer to relevant datasheet | F = 50 V _{DC} H = 100 V _{DC} K = 200 V _{DC} | 5 = 0.50 mm ± 0.05 mm | 3 = bulk T = tape and reel U = ammo | H = flat crimp L = straight K = outside crimp | 2 = 2.5 mm 5 = 5.0 mm | G = AEC-Q200 qualified and Vishay Green |



ORDERING CODES

| DIELECTRIC COG | | | |
|----------------|--------------------|---------------------|---------------------|
| CAP. (pF) | 50 V _{DC} | 100 V _{DC} | 200 V _{DC} |
| 100 | K101#15C0GF5###G | K101#15C0GH5###G | K101#15C0GK5###G |
| 120 | K121#15C0GF5###G | K121#15C0GH5###G | K121#15C0GK5###G |
| 150 | K151#15C0GF5###G | K151#15C0GH5###G | K151#15C0GK5###G |
| 180 | K181#15C0GF5###G | K181#15C0GH5###G | K181#15C0GK5###G |
| 220 | K221#15C0GF5###G | K221#15C0GH5###G | K221#15C0GK5###G |
| 270 | K271#15C0GF5###G | K271#15C0GH5###G | K271#15C0GK5###G |
| 330 | K331#15C0GF5###G | K331#15C0GH5###G | K331#15C0GK5###G |
| 390 | K391#15C0GF5###G | K391#15C0GH5###G | K391#15C0GK5###G |
| 470 | K471#15C0GF5###G | K471#15C0GH5###G | K471#15C0GK5###G |
| 560 | K561#15C0GF5###G | K561#15C0GH5###G | K561#15C0GK5###G |
| 680 | K681#15C0GF5###G | K681#15C0GH5###G | K681#15C0GK5###G |
| 820 | K821#15C0GF5###G | K821#15C0GH5###G | K821#15C0GK5###G |
| 1000 | K102#15C0GF5###G | K102#15C0GH5###G | K102#15C0GK5###G |
| 1200 | K122#15C0GF5###G | K122#15C0GH5###G | K122#20C0GK6###G |
| 1500 | K152#15C0GF5###G | K152#15C0GH5###G | K152#20C0GK6###G |
| 1800 | K182#15C0GF5###G | K182#15C0GH5###G | K182#20C0GK6###G |
| 2200 | K222#15C0GF5###G | K222#20C0GH6###G | K222#20C0GK6###G |
| 2700 | K272#15C0GF5###G | K272#20C0GH6###G | K272#20C0GK6###G |
| 3300 | K332#15C0GF5###G | K332#20C0GH6###G | K332#20C0GK6###G |
| 3900 | K392#15C0GF5###G | K392#20C0GH6###G | K392#20C0GK6###G |
| 4700 | K472#20C0GF6###G | K472#20C0GH6###G | K472#20C0GK6###G |
| 5600 | K562#20C0GF6###G | K562#20C0GH6###G | K562#20C0GK6###G |
| 6800 | K682#20C0GF6###G | K682#20C0GH6###G | K682#20C0GK6###G |
| 8200 | K822#20C0GF6###G | K822#20C0GH6###G | K822#20C0GK6###G |
| 12 000 | K123#20C0GF6###G | K123#20C0GH6###G | - |

Notes

- Lead diameter is 0.5 mm for size 15 and 0.6 mm for size 20
- # 5th digit is capacitance tolerance code: ± 5 % = J; ± 10 % = K
- # 13th digit is packaging code: bulk = 3; reel = T; ammo = U
- # 14th digit is lead style code: L; H; K (L and H are preferred lead configuration)
- # 15th digit is lead spacing code: 2.5 mm = 2; 5.0 mm = 5



| DIELECTRIC X7R | | | |
|----------------|--------------------|---------------------|---------------------|
| CAP. (pF) | 50 V _{DC} | 100 V _{DC} | 200 V _{DC} |
| 330 | K331#15X7RF5###G | K331#15X7RH5###G | K331#15X7RK5###G |
| 390 | K391#15X7RF5###G | K391#15X7RH5###G | K391#15X7RK5###G |
| 470 | K471#15X7RF5###G | K471#15X7RH5###G | K471#15X7RK5###G |
| 560 | K561#15X7RF5###G | K561#15X7RH5###G | K561#15X7RK5###G |
| 680 | K681#15X7RF5###G | K681#15X7RH5###G | K681#15X7RK5###G |
| 820 | K821#15X7RF5###G | K821#15X7RH5###G | K821#15X7RK5###G |
| 1000 | K102#15X7RF5###G | K102#15X7RH5###G | K102#15X7RK5###G |
| 1200 | K122#15X7RF5###G | K122#15X7RH5###G | K122#15X7RK5###G |
| 1500 | K152#15X7RF5###G | K152#15X7RH5###G | K152#15X7RK5###G |
| 1800 | K182#15X7RF5###G | K182#15X7RH5###G | K182#15X7RK5###G |
| 2200 | K222#15X7RF5###G | K222#15X7RH5###G | K222#15X7RK5###G |
| 2700 | K272#15X7RF5###G | K272#15X7RH5###G | K272#15X7RK5###G |
| 3300 | K332#15X7RF5###G | K332#15X7RH5###G | K332#15X7RK5###G |
| 3900 | K392#15X7RF5###G | K392#15X7RH5###G | K392#15X7RK5###G |
| 4700 | K472#15X7RF5###G | K472#15X7RH5###G | K472#15X7RK5###G |
| 5600 | K562#15X7RF5###G | K562#15X7RH5###G | K562#15X7RK5###G |
| 6800 | K682#15X7RF5###G | K682#15X7RH5###G | K682#15X7RK5###G |
| 8200 | K822#15X7RF5###G | K822#15X7RH5###G | K822#15X7RK5###G |
| 10 000 | K103#15X7RF5###G | K103#15X7RH5###G | K103#15X7RK5###G |
| 12 000 | K123#15X7RF5###G | K123#15X7RH5###G | K123#15X7RK5###G |
| 15 000 | K153#15X7RF5###G | K153#15X7RH5###G | K153#15X7RK5###G |
| 18 000 | K183#15X7RF5###G | K183#15X7RH5###G | K183#15X7RK5###G |
| 22 000 | K223#15X7RF5###G | K223#15X7RH5###G | K223#15X7RK5###G |
| 27 000 | K273#15X7RF5###G | K273#15X7RH5###G | K273#15X7RK5###G |
| 33 000 | K333#15X7RF5###G | K333#15X7RH5###G | K333#20X7RK6###G |
| 39 000 | K393#15X7RF5###G | K393#15X7RH5###G | K393#20X7RK6###G |
| 47 000 | K473#15X7RF5###G | K473#15X7RH5###G | K473#20X7RK6###G |
| 56 000 | K563#15X7RF5###G | K563#15X7RH5###G | K563#20X7RK6###G |
| 68 000 | K683#15X7RF5###G | K683#15X7RH5###G | K683#20X7RK6###G |
| 82 000 | K823#15X7RF5###G | K823#15X7RH5###G | K823#20X7RK6###G |
| 100 000 | K104#15X7RF5###G | K104#15X7RH5###G | K104#20X7RK6###G |
| 120 000 | K124#15X7RF5###G | K124#20X7RH6###G | K124#20X7RK6###G |
| 150 000 | K154#20X7RF6###G | K154#20X7RH6###G | K154#20X7RK6###G |
| 180 000 | K184#20X7RF6###G | K184#20X7RH6###G | K184#20X7RK6###G |
| 220 000 | K224#20X7RF6###G | K224#20X7RH6###G | - |
| 270 000 | K274#20X7RF6###G | K274#20X7RH6###G | - |
| 330 000 | K334#20X7RF6###G | K334#20X7RH6###G | - |
| 390 000 | K394#20X7RF6###G | K394#20X7RH6###G | - |
| 470 000 | K474#20X7RF6###G | K474#20X7RH6###G | - |
| 560 000 | K564#20X7RF6###G | - | - |
| 680 000 | K684#20X7RF6###G | - | - |
| 820 000 | K824#20X7RF6###G | - | - |
| 1 000 000 | K105#20X7RF6###G | - | - |

Notes

- Lead diameter is 0.5 mm for size 15 and 0.6 mm for size 20
- # 5th digit is capacitance tolerance code: ± 10 % = K; ± 20 % = M
- # 13th digit is packaging code: bulk = 3; reel = T; ammo = U
- # 14th digit is lead style code: L; H; K (L and H are preferred lead configuration)
- # 15th digit is lead spacing code: 2.5 mm = 2; 5.0 mm = 5

TAPING AND PACKAGING
LABELLING

Each reel is provided with a label showing the following details:

manufacturer, K style, capacitance, tolerance, batch number, quantity of components, rated voltage, dielectric.

On special request other designations can be shown.

For example:

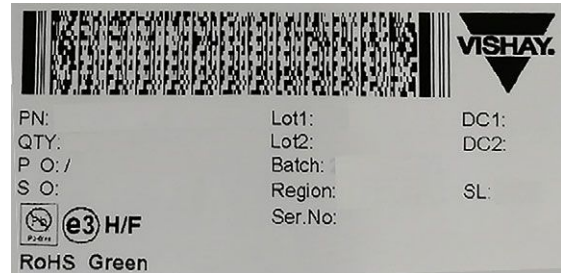

| PACKAGING QUANTITIES AND BOX DIMENSIONS | | | |
|---|-----------|-----------------------------------|-------------------------------|
| PACKAGING | SIZE CODE | SMALLEST PACKAGING QUANTITY (SPQ) | BOX DIMENSIONS L x W x H (mm) |
| Tape on reel | 15 | 4000 | 370 x 370 x 60 |
| | 20 | 3000 | |
| Ammopack | 15, 20 | 2500 | 335 x 290 x 50 |
| Bulk ⁽¹⁾ | 15, 20 | 5000 | 245 x 120 x 65 |

Note

⁽¹⁾ SPQ contains one or a multiple of poly-bags, 1000 units per bag.

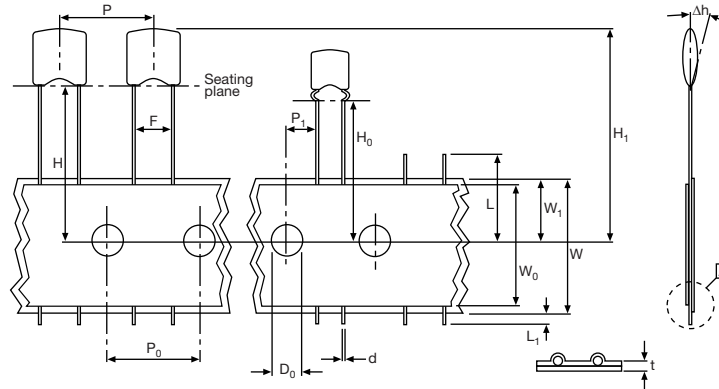
CAPACITORS ON TAPE

| PARAMETER | SYMBOL | DIMENSIONS | |
|---|----------------|-----------------------|-------------------------|
| | | mm | INCH |
| Cut-off length | L | ≤ 11.0 | ≤ 0.443 |
| Lead end protrusion | L ₁ | ≤ 1.0 | ≤ 0.039 |
| Height to seating plane (straight leads) | H | ≥ 18.0 | ≥ 0.709 |
| Height to seating plane (crimp leads) | H ₀ | 16.0 ± 0.5 | 0.630 ± 0.020 |
| Top of component height | H ₁ | ≤ 32 | ≤ 1.26 |
| Body inclination | Δh | 0.0 ± 1.0 | 0.000 ± 0.039 |
| Carrier tape width | W | 18.0 + 1.0 / - 0.5 | 0.709 + 0.039 / - 0.020 |
| Hold down tape width | W ₀ | 15.0 REF. | 0.591 REF. |
| Sprocket hole position | W ₁ | 9.00 + 0.075 / - 0.50 | 0.354 + 0.030 / - 0.020 |
| Lead space | F | 2.50 + 0.60 / - 0.40 | 0.100 + 0.024 / - 0.016 |
| | | 5.00 + 0.60 / - 0.40 | 0.200 + 0.024 / - 0.016 |
| Sprocket hole pitch | P ₀ | 12.70 ± 0.30 | 0.500 ± 0.012 |
| Sprocket hole center to lead center at F = 2.5 mm | P ₁ | 5.08 ± 0.70 | 0.200 ± 0.028 |
| Sprocket hole center to lead center at F = 5 mm | | 3.85 ± 0.70 | 0.150 ± 0.028 |
| Sprocket hole diameter | D ₀ | 4.00 ± 0.30 | 0.157 ± 0.012 |
| Overall tape thickness | t | ≤ 0.90 | ≤ 0.035 |
| Wire lead diameter | d | 0.50 ± 0.05 | 0.020 ± 0.002 |
| Taping pitch | P | 12.7 REF. | 0.50 REF. |

REEL DATA

A maximum of 0.5 % of the total number of capacitors per reel may be missing.

A maximum of 1 consecutive vacant positions is followed by 6 consecutive components.

Tape begins and ends with a minimum of 4 empty positions (50 mm tape).

Maximum of 5 splicers per reel.

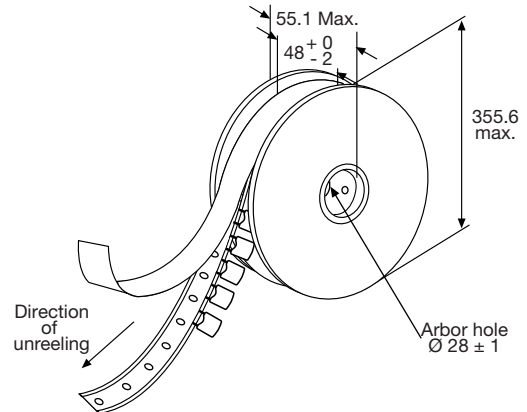
REEL

| REEL DIMENSIONS | | |
|-----------------|----------------|--------------|
| | | |
| REEL SIZE | | (mm) |
| A | Outer diameter | 355.6 max. |
| L | Hole diameter | 28 ± 1 |
| K | Core diameter | 90 |
| H ₁ | Internal width | 48 + 0 / - 2 |
| H ₂ | External width | 55 max. |

AMMOPACK DATA

A maximum of 0.5 % of the total number of capacitors per pack may be missing.

A maximum of 1 consecutive vacant positions is followed by 6 consecutive components.

Tape begins and ends with a minimum of 4 empty positions (50 mm tape).

Maximum of 5 splicers per pack.

The cumulative pitch tolerance over 20 consecutive units is not to exceed ± 1.0 mm.

Lead space (F) shall be measured at (3.6 ± 0.5) mm from the capacitor seating plane.

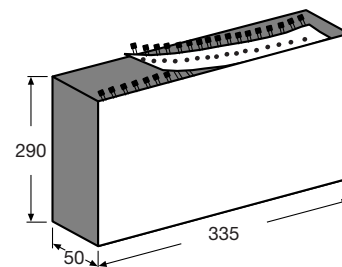
AMMOPACK

| RELATED DOCUMENTS | |
|---------------------|--|
| General Information | www.vishay.com/doc?45214 |



Disclaimer

ALL PRODUCT, PRODUCT SPECIFICATIONS AND DATA ARE SUBJECT TO CHANGE WITHOUT NOTICE TO IMPROVE RELIABILITY, FUNCTION OR DESIGN OR OTHERWISE.

Vishay Intertechnology, Inc., its affiliates, agents, and employees, and all persons acting on its or their behalf (collectively, "Vishay"), disclaim any and all liability for any errors, inaccuracies or incompleteness contained in any datasheet or in any other disclosure relating to any product.

Vishay makes no warranty, representation or guarantee regarding the suitability of the products for any particular purpose or the continuing production of any product. To the maximum extent permitted by applicable law, Vishay disclaims (i) any and all liability arising out of the application or use of any product, (ii) any and all liability, including without limitation special, consequential or incidental damages, and (iii) any and all implied warranties, including warranties of fitness for particular purpose, non-infringement and merchantability.

Statements regarding the suitability of products for certain types of applications are based on Vishay's knowledge of typical requirements that are often placed on Vishay products in generic applications. Such statements are not binding statements about the suitability of products for a particular application. It is the customer's responsibility to validate that a particular product with the properties described in the product specification is suitable for use in a particular application. Parameters provided in datasheets and / or specifications may vary in different applications and performance may vary over time. All operating parameters, including typical parameters, must be validated for each customer application by the customer's technical experts. Product specifications do not expand or otherwise modify Vishay's terms and conditions of purchase, including but not limited to the warranty expressed therein.

Hyperlinks included in this datasheet may direct users to third-party websites. These links are provided as a convenience and for informational purposes only. Inclusion of these hyperlinks does not constitute an endorsement or an approval by Vishay of any of the products, services or opinions of the corporation, organization or individual associated with the third-party website. Vishay disclaims any and all liability and bears no responsibility for the accuracy, legality or content of the third-party website or for that of subsequent links.

Except as expressly indicated in writing, Vishay products are not designed for use in medical, life-saving, or life-sustaining applications or for any other application in which the failure of the Vishay product could result in personal injury or death. Customers using or selling Vishay products not expressly indicated for use in such applications do so at their own risk. Please contact authorized Vishay personnel to obtain written terms and conditions regarding products designed for such applications.

No license, express or implied, by estoppel or otherwise, to any intellectual property rights is granted by this document or by any conduct of Vishay. Product names and markings noted herein may be trademarks of their respective owners.