

**STRATUM 3 SIMPLIFIED CONTROL
 TIMING MODULES (STM-S3)**

DESCRIPTION

The Connor-Winfield Stratum 3 Simplified Control Timing Module acts as a complete system clock module for general Stratum 3 timing applications. The STM is designed for external control functions. Full external control input allows for selection and monitoring of any of four possible operating states: 1) Holdover, 2) External Reference #1, 3) External Reference #2, and 4) Free Run. The table below illustrates the control signal inputs and corresponding operational states:

In the absence of External Control Inputs (A,B), the STM enters the Free Run mode and signals an External Alarm. The STM will enter other operating modes upon application of a proper control signal. Mode 1 operation (A=1, B=0) results in an output signal that is phase locked to the External Reference Input #1. Mode 2 operation (A=0, B=1) results in an output signal that is phase locked to External Reference Input #2. Holdover mode operation (A=1, B=1) results in an output signal at or near the frequency as determined by the latest (last) locked-signal input values and the holdover performance of the STM.

Alarm signals are generated at the Alarm Output during Holdover and Free Run operation. Alarm Signals are also generated by loss-of-lock, loss of Reference, and by a Tune-Limit indication from the PLL. A Tune-Limit alarm signal indicates that the VCXO tuning voltage is approaching within 10% the limits of its lock capability and that the External Reference Input may be erroneous. A high level indicates an alarm condition. Real-time indication of the operational mode is available at unique operating mode outputs on pins 1-4.

Control loop filters effectively attenuate any reference jitter and smooth out phase transients.

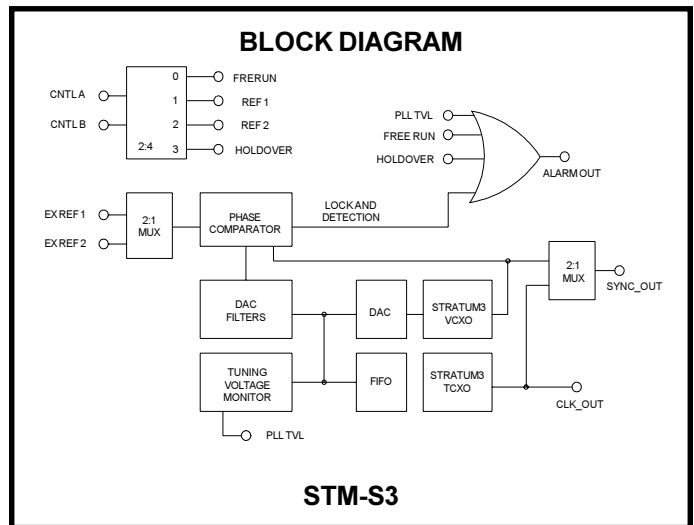
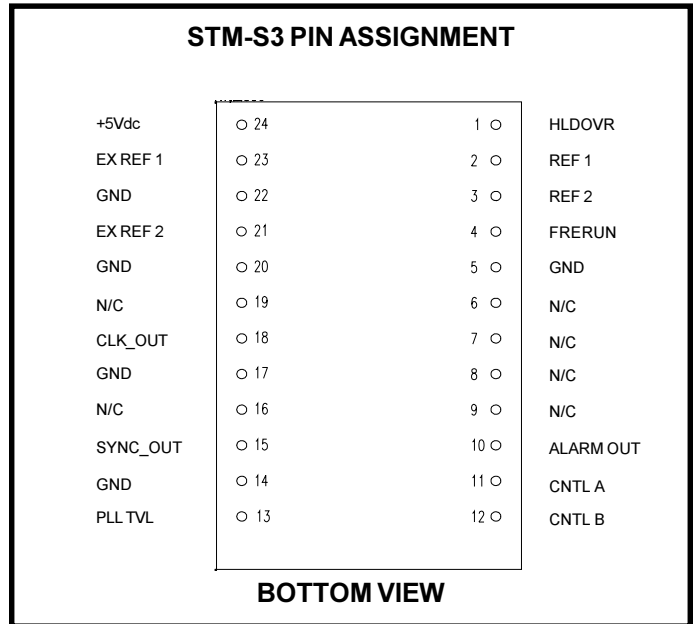

CONTROL INPUT		OPERATIONAL MODE		REF 1	REF 2	HLDOVR	FRERUN	PLL_TVL*	ALARM OUTPUT
A	B								
0	0	Free Run (Default)		0	0	0	1	0	1
1	0	External Reference #1	Normal	1	0	0	0	0	0
			Tune Limit	1	0	0	0	1	1
			LOS + LOL	1	0	0	0	0	1
0	1	External Reference #2	Normal	0	1	0	0	0	0
			Tune Limit	0	1	0	0	1	1
			LOS + LOL	0	1	0	0	0	1
1	1	Holdover		0	0	1	0	0	1



**STRATUM 3 SIMPLIFIED CONTROL
 TIMING MODULES (STM-S3)**

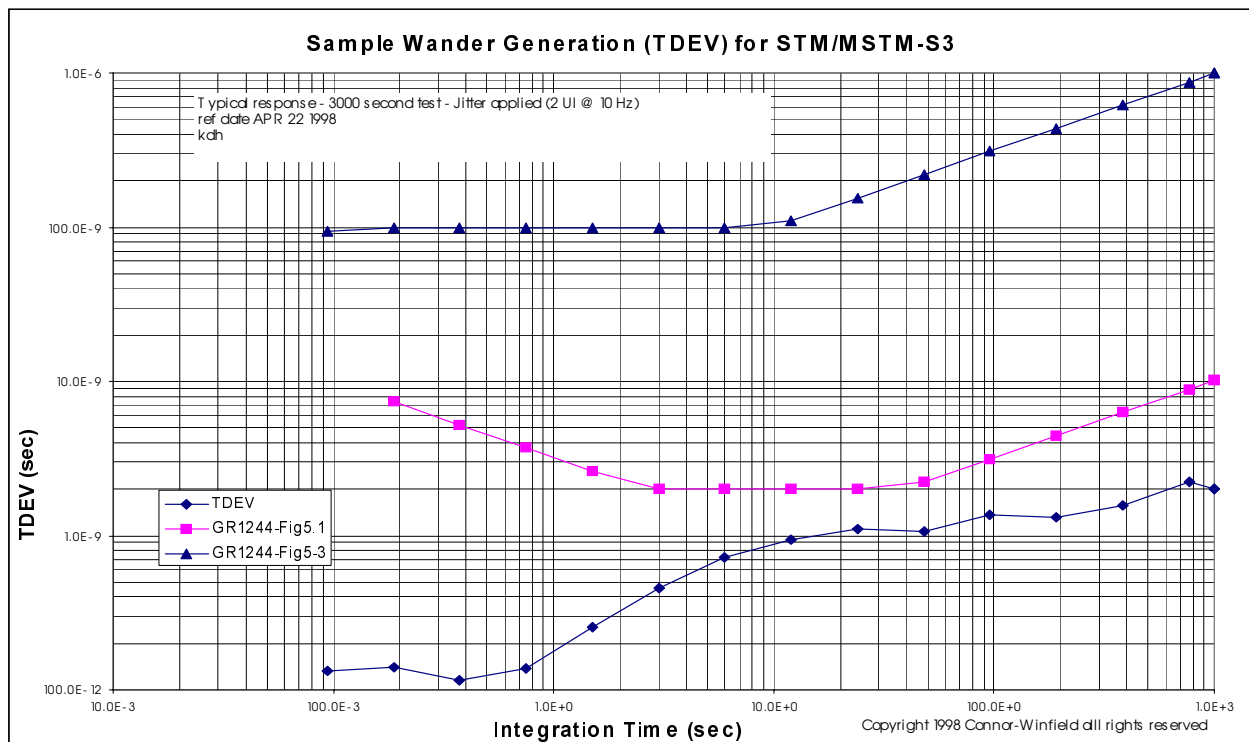
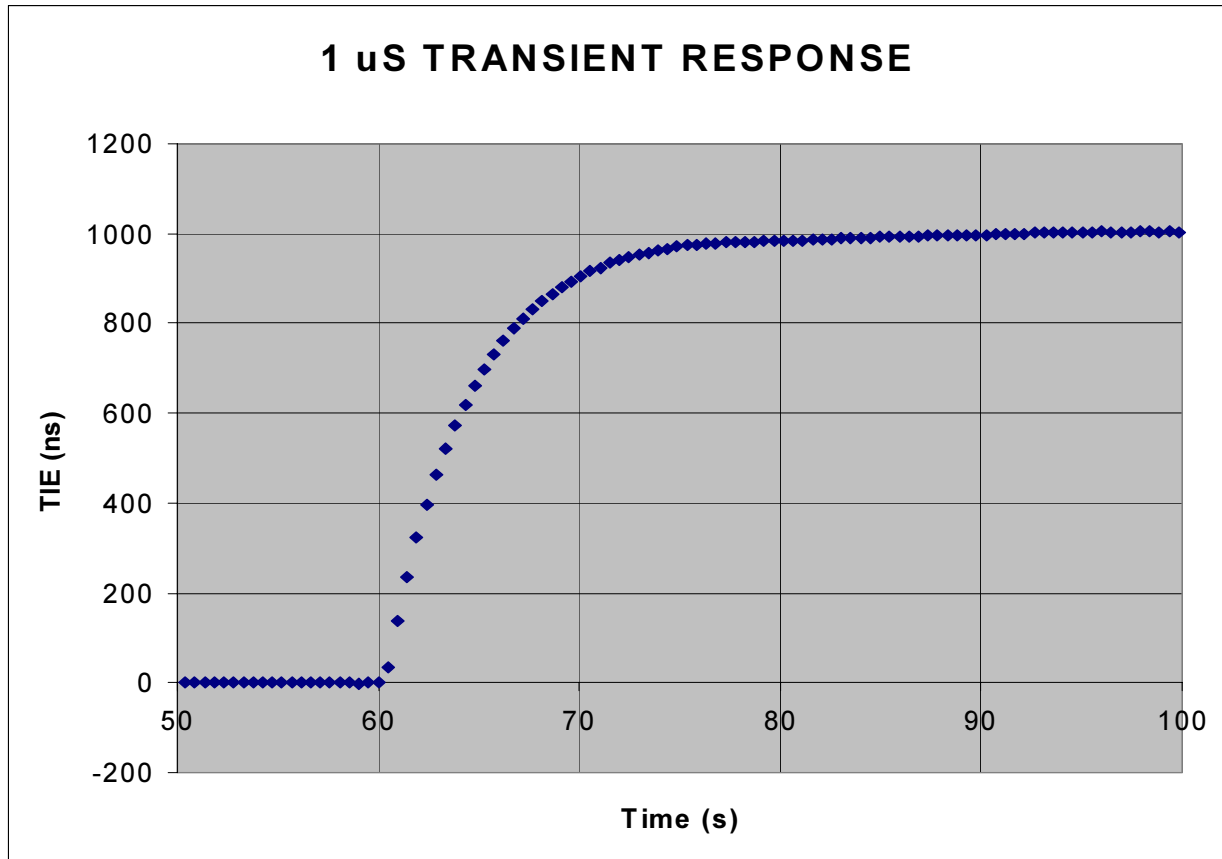



**STRATUM 3 SIMPLIFIED CONTROL
 TIMING MODULES (STM-S3)**

Sample MTIE Data for STM-S3/MSTM-S3

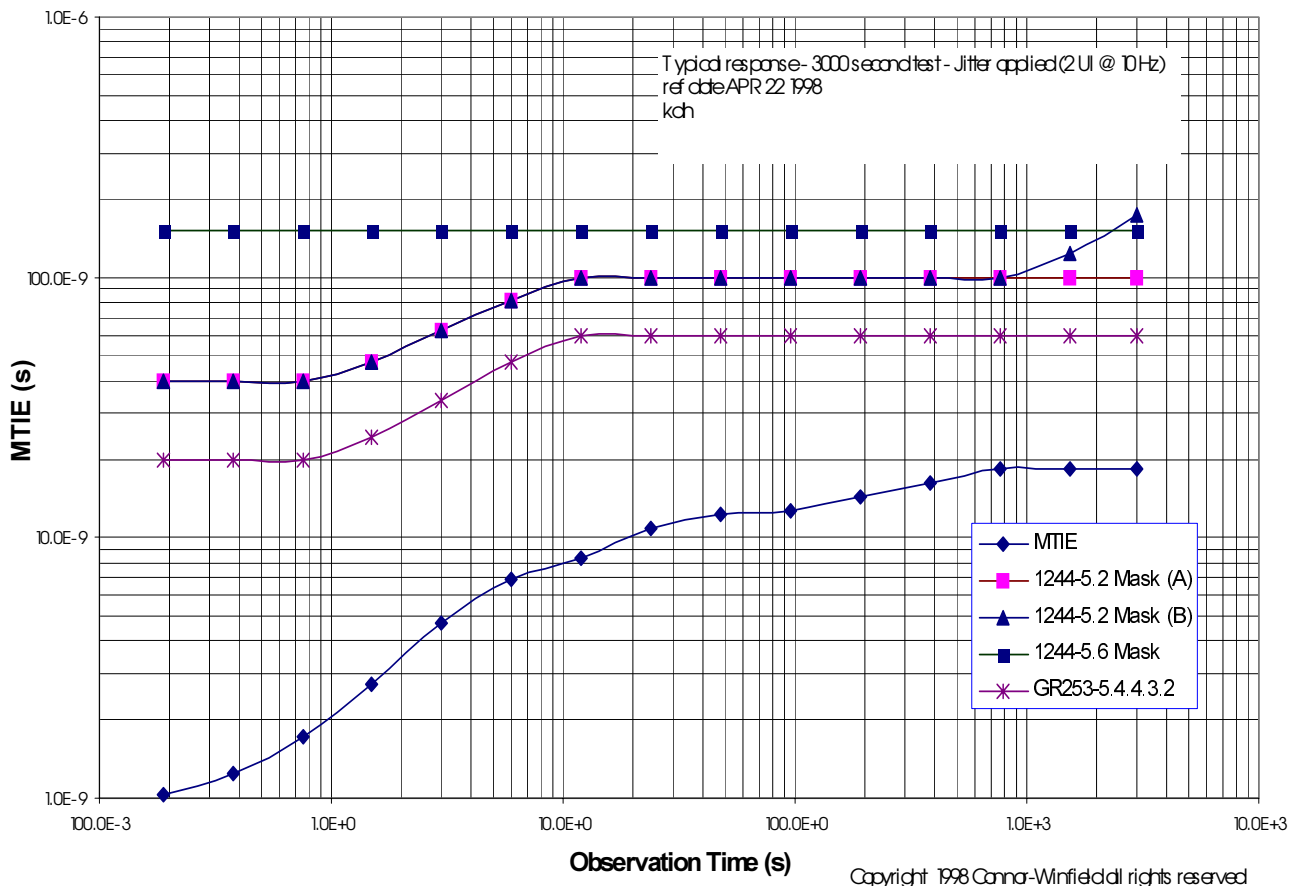

Copyright 1998 Connor-Winfield all rights reserved



**STRATUM 3 SIMPLIFIED CONTROL
 TIMING MODULES (STM-S3)**

TABLES OF CONTENTS

TABLE 1.0 ABSOLUTE MAXIMUM RATING

SYMBOL	PARAMETER	MINIMUM	NOMINAL	MAXIMUM	UNITS	NOTES
V _{CC}	Power supply voltage (V _{CC} to GND)	-0.5		+7.0	Volts	1.0
V _{IN}	Input voltage with respect to ground	-0.5		V _{CC} +0.5	Volts	1.0
T _{STG}	Storage temperature	-65.0		+150.0	deg. C	1.0

NOTE 1.0: Operation of the device at these or any other conditions beyond those listed under Recommended Operating Conditions is not implied. Exposure to Absolute Maximum Ratings conditions for extended periods of time may affect device reliability.

TABLE 2.0 INPUT AND OUTPUT CHARACTERISTICS

SYMBOL	PARAMETER	MINIMUM	NOMINAL	MAXIMUM	UNITS	NOTES
V _{IH}	High level input voltage (TTL Compatible)	2.0		V _{CC}	V	
V _{IL}	Low level input voltage (TTL Compatible)	0		0.8	V	
T _{IN}	Input signal transition time			250	nS	
C _{IN}	Input capacitance			15	pF	
V _{OH}	High level output voltage @ I _{OH} = -8.0 mA, V _{CC} minimum	3.86			V	
V _{OL}	Low level output voltage @ I _{OL} = 8.0 mA, V _{CC} maximum			0.4	V	
T _{HL}	Clock out transition time high-to-low, no load		4.0		nS	
T _{LH}	Clock out transition time low-to-high, no load		4.0		nS	
T _{RIP}	Input 8 KHz reference signal positive pulse width	30			nS	
T _{RIN}	Input 8 KHz reference signal negative pulse width	30			nS	
T _{OP1}	Standard Operating Temperature	0		50	deg. C	
T _{OP2}	Optional Operating Temperature	0		70	deg. C	8.0

TABLE 3.0 SPECIFICATIONS

PARAMETER		NOTES
Frequency Range	16.384 MHz , 19.44 MHz	5.0
Supply Current	60 mA Typical at 16.384 MHz	9.0
Timing Reference Inputs	8 KHz	6.0
Jitter and Phase Tolerance	Ref-GR-1244-CORE 4.2-4.4	
Wander Generation	Ref-GR-1244-CORE 5.3	
Free-Run Accuracy	±4.6 ppm	
Holdover Stability	±0.37 ppm	2.0
Initial Offset	0.05 ppm	
Temperature	0.28 ppm	
Drift	0.04 ppm	
Holdover History	30 seconds	
Pull-in / Hold-in Range	±4.6 ppm Minimum	3.0
Lock Time	< 100 secs	
Correction Period	125 uS	
TVL Alarm	1= WARNING: Reference nearing operational limit	7.0

INT Specifications subject to change without notice.

**STRATUM 3 SIMPLIFIED CONTROL
TIMING MODULES (STM-S3)****PIN DESCRIPTION****STM-S3
PIN #**

1	HLDOVR	-Output. High when the control inputs select Holdover.
2	REF_1	-Output. High when the control inputs select EX REF_1.
3	REF_2	-Output. High when the control inputs select EX REF_2.
4	FRERUN	-Output. High when the control input selects Free Run.
5	Gnd	-Ground.
10	ALARM_OUT	-Output. =1, If (FRERUN + HOLDOVER + LOS + LOL + PLL_TVL) .
11	CNTL_A	-Mode control input.
12	CNTL_B	-Mode control input.
13	PLL_TVL	-Tuning Voltage Alarm. =1 If CAPTURE RANGE NEAR 10% OF EXTREME (~11ppm).
14	Gnd	-Ground.
15	SYNC_OUT	-Synchronized output.
17	Gnd	-Ground.
18	CLK_OUT	-Stratum 3 TCXO output. (Non-synchronized).
20	Gnd	-Ground.
21	EX_REF_2	-External Reference #2 Input. (8 KHz)
22	Gnd	-Ground.
23	EX_REF_1	-Input. External Reference #1 Input. (8 KHz)
24	+5 Vdc	+5 Volt DC supply.

NOTES FOR TABLES 1-3**NOTES:**

- 2.0 Holdover stability is the cumulative fractional frequency offset containing Initial Offset, Temperature, and Drift components as described by Bellcore GR-1244-CORE 5.2.
- 3.0 Pull-in range is the minimum frequency deviation on the reference inputs to the timing module that can be overcome to pull itself into synchronization with the reference.
- 4.0 After 100 seconds at stable room temperature.
- 5.0 Consult factory for other output frequencies.
- 6.0 Ref- GR1244-CORE 3.2.1 R3-1.
- 7.0 A '1' level indicates unit is within the extreme 10% of its operating range tracking the reference (~11ppm). Consult factory for use as a reference quillifier.
- 8.0 Add '-T2' to model number.
- 9.0 Consult factory for power dissipation of -T2 (0 to +70 deg. C.) devices.

INT

Specifications subject to change without notice.

**STRATUM 3 SIMPLIFIED CONTROL
 TIMING MODULES (STM-S3)**

**STM-S3
 PACKAGE
 WITH COVER**

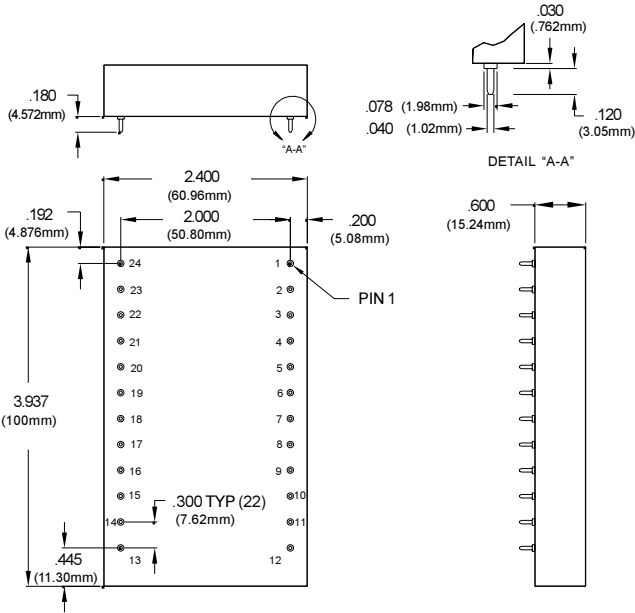

BOTTOM VIEW

APPLICATIONS CIRCUIT DIAGRAM

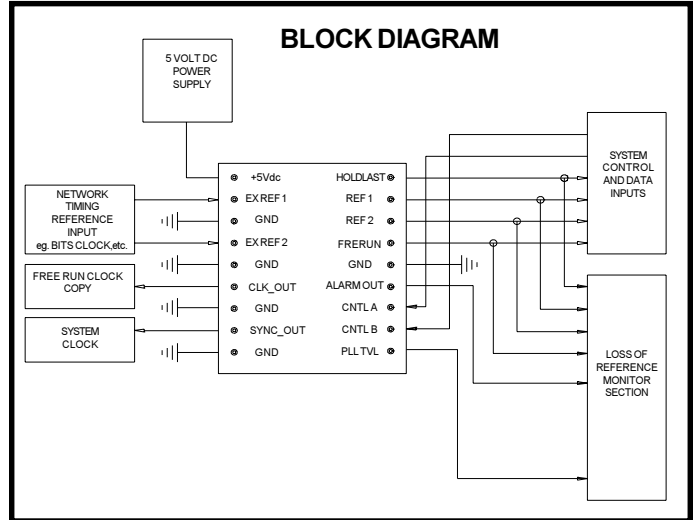

BLOCK DIAGRAM

MECHANICAL CHARACTERISTICS

MECHANICAL SHOCK 883D 2002 CONDITION B
 1500 G's 0.5 ms.

VIBRATION 883D-2007 CONDITION A
 0.06" DA or 20 g Peak Acceleration 20 to 2000 Hz.

ENVIRONMENTAL CHARACTERISTICS

TEMPERATURE CYCLE 883D METHOD 1010.7 CONDITION B
 10 Cycles -55 to +125 Degrees C.

HTOB - HIGH TEMPERATURE OPERATING BIAS
 1000 Hours +125 Degrees C.

FACTORY RELIABILITY AUDIT

TEMPERATURE CYCLE
 500 Cycles -55 to +125 Degrees C.

HTOB - HIGH TEMPERATURE OPERATING BIAS
 1000 Hours +125 Degrees C.

PARTS TO BE QUALIFIED TO BELLCORE TR-NWT-00357

TEMPERATURE CYCLE
 -40 to +85 Degrees C.

72 HOUR BURN-IN
 +25 Degrees C.