

## 150mA 10V INPUT LDO REGULATOR

No. EA-245-200219

### OUTLINE

The RP171x is LDO regulator featuring 150mA output current. Because of the 10V maximum input voltage, RP171x can be used in 2 cell lithium-ion battery powered portable appliances and besides a portable equipment. The supply current is Typ. 23 $\mu$ A though an excellent response characteristics.

The output voltage range from 1.2V is possible. The output voltage accuracy and temperature-drift coefficient of output voltage of the RP171x Series are excellent.

RP171x has a fold-back protection circuit and a thermal shutdown circuit. Moreover, a standby mode with ultra-low supply current can be realized with the chip enable function.

SC-88A and SOT-23-5 with high power dissipation packages are available.

### FEATURES

- Supply Current ..... Typ. 23 $\mu$ A
- Standby Mode ..... Typ. 0.1 $\mu$ A
- Dropout Voltage ..... Typ. 0.20V ( $I_{OUT}=100mA$ ,  $V_{OUT}=3.0V$ )  
Typ. 0.40V ( $I_{OUT}=150mA$ ,  $V_{OUT}=2.8V$ )
- Ripple Rejection ..... Typ. 70dB ( $f=1kHz$ )
- Temperature-Drift Coefficient of Output Voltage ..... Typ.  $\pm 80ppm/^{\circ}C$
- Line Regulation ..... Typ. 0.02%/V
- Output Voltage Accuracy .....  $\pm 1.0\%$
- Packages ..... SC-88A, SOT-23-5
- Input Voltage Range ..... 2.6V to 10.0V
- Output Voltage Range ..... 1.2V to 6.5V (0.1V steps)  
(For other voltages, please refer to  
MARK INFORMATIONS.)
- Built-in Fold Back Protection Circuit ..... Typ. 40mA (Current at short mode)
- Built-in Thermal Shutdown Circuit ..... Shutdown Temperature at 165 $^{\circ}C$
- Built-in Constant Slope Circuit (Soft-start Function)
- Ceramic capacitors are recommended to be used with this IC ..... 1.0 $\mu$ F or more

### APPLICATIONS

- Power source for portable communication equipment.
- Power source for electrical appliances such as cameras, VCRs and camcorders.
- Power source for battery-powered equipment.
- Power source for home appliances.

---

## RP171x

---

No. EA-245-200219

## SELECTION GUIDE

The output voltage, auto-discharge<sup>(1)</sup> function, and package, etc. for the ICs can be selected at the user's request.

Product Name	Package	Quantity per Reel	Pb Free	Halogen Free
RP171Qxx2*-TR-FE	SC-88A	3,000 pcs	Yes	Yes
RP171Nxx1*-TR-FE	SOT-23-5	3,000 pcs	Yes	Yes

xx: The output voltage can be designated in the range from 1.2V(12) to 6.5V(65) in 0.1V steps.

The voltage in 0.05 V step is shown as follows.

Example. 1.25 V: RP171x12x\*5

\* : The auto discharge function at off state are options as follows.

(B) without auto discharge function at off state

(D) with auto discharge function at off state

## BLOCK DIAGRAMS

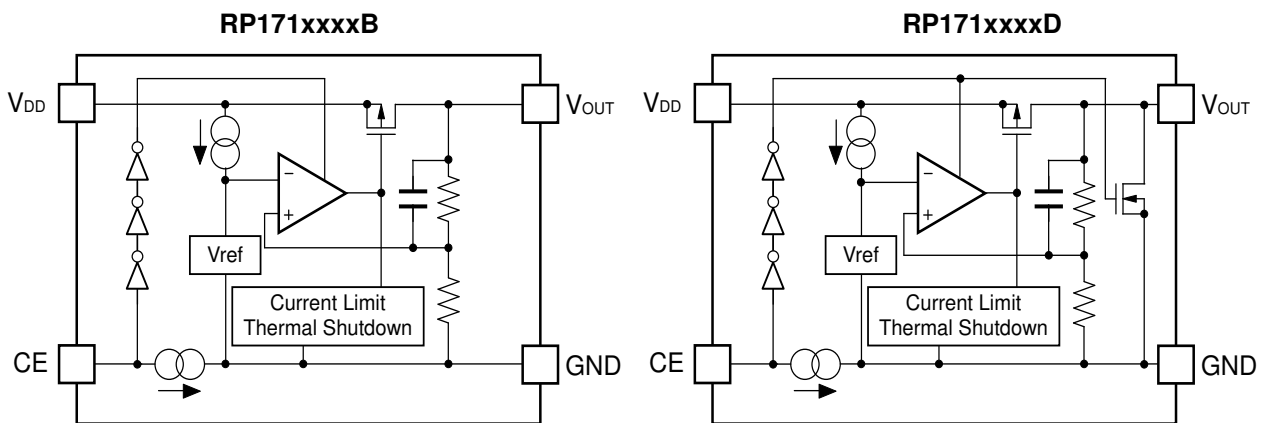

---

<sup>(1)</sup> Auto-discharge function quickly lowers the output voltage to 0V by releasing the electrical charge accumulated in the external capacitor when the chip enable signal is switched from the active mode to the standby mode.

---

## PIN CONFIGURATIONS

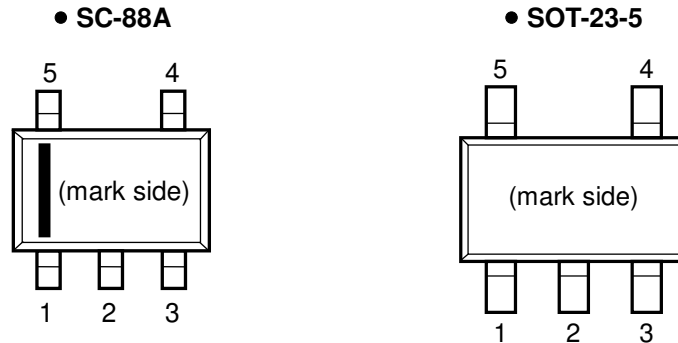

## PIN DESCRIPTIONS

### • SC-88A

Pin No.	Symbol	Pin Description
1	CE	Chip Enable Pin ("H" Active)
2 *	NC	No Connection
3	GND	Ground Pin
4	VOUT	Output Pin
5	VDD	Input Pin

\* Pin No. 2 is connected to the bottom of the IC. It is recommended that the pin be connected to the ground plane on the board, or otherwise be left floating so that there is no contact with other potentials.

### • SOT-23-5

Pin No	Symbol	Pin Description
1	VDD	Input Pin
2	GND	Ground Pin
3	CE	Chip Enable Pin ("H" Active)
4	NC	No Connection
5	VOUT	Output Pin

## RP171x

No. EA-245-200219

### ABSOLUTE MAXIMUM RATINGS

Symbol	Item	Rating	Unit	
$V_{IN}$	Input Voltage	12	V	
$V_{CE}$	Input Voltage (CE Pin)	12	V	
$V_{OUT}$	Output Voltage	-0.3 to $V_{IN}+0.3$	V	
$I_{OUT}$	Output Current	330	mA	
$P_D$	Power Dissipation <sup>(1)</sup>	SC-88A (Our Standard Test Land Pattern)	380	mW
		SOT-23-5 (JEDEC STD. 51-7)	660	
$T_j$	Junction Temperature Range	-40 to 125	°C	
$T_{stg}$	Storage Temperature Range	-55 to 125	°C	

#### ABSOLUTE MAXIMUM RATINGS

Electronic and mechanical stress momentarily exceeded absolute maximum ratings may cause permanent damage and may degrade the life time and safety for both device and system using the device in the field. The functional operation at or over these absolute maximum ratings is not assured.

### RECOMMENDED OPERATING CONDITIONS

Symbol	Parameter	Rating	Unit
$V_{IN}$	Input Voltage	2.6 to 10	V
$T_a$	Operating Temperature Range	-40 to 85	°C

#### RECOMMENDED OPERATING CONDITIONS

All of electronic equipment should be designed that the mounted semiconductor devices operate within the recommended operating conditions. The semiconductor devices cannot operate normally over the recommended operating conditions, even if they are used over such ratings by momentary electronic noise or surge. And the semiconductor devices may receive serious damage when they continue to operate over the recommended operating conditions.

<sup>(1)</sup>Refer to POWER DISSIPATION for detailed information

## ELECTRICAL CHARACTERISTICS

$V_{IN} = \text{Set } V_{OUT} + 1V$ ,  $I_{OUT} = 1mA$ , unless otherwise noted.

The specifications in   are guaranteed by Design Engineering at  $-40^{\circ}C \leq T_a \leq 85^{\circ}C$ .

### RP171xxxxB/D

( $T_a = 25^{\circ}C$ )

Symbol	Item	Conditions	Min.	Typ.	Max.	Unit	
$V_{OUT}$	Output Voltage	$T_a = 25^{\circ}C$	$V_{OUT} > 1.5V$	$\times 0.99$		$\times 1.01$	V
			$V_{OUT} \leq 1.5V$	-15		+15	mV
		$-40^{\circ}C \leq T_a \leq 85^{\circ}C$	$V_{OUT} > 1.5V$	<span style="border: 1px solid black; padding: 0 2px;"><math>\times 0.974</math></span>		<span style="border: 1px solid black; padding: 0 2px;"><math>\times 1.023</math></span>	V
			$V_{OUT} \leq 1.5V$	<span style="border: 1px solid black; padding: 0 2px;">-40</span>		<span style="border: 1px solid black; padding: 0 2px;">+35</span>	mV
$I_{OUT}$	Output Current		<span style="border: 1px solid black; padding: 0 2px;">150</span>			mA	
$\Delta V_{OUT}/\Delta I_{OUT}$	Load Regulation	$0.1mA \leq I_{OUT} \leq 150mA$		5	<span style="border: 1px solid black; padding: 0 2px;">40</span>	mV	
$V_{DIF}$	Dropout Voltage	$I_{OUT} = 150mA$	$1.2V \leq V_{OUT} < 1.3V$		-	<span style="border: 1px solid black; padding: 0 2px;">1.400</span>	V
			$1.3V \leq V_{OUT} < 1.5V$		-	<span style="border: 1px solid black; padding: 0 2px;">1.300</span>	
			$1.5V \leq V_{OUT} < 1.8V$		-	<span style="border: 1px solid black; padding: 0 2px;">1.100</span>	
			$1.8V \leq V_{OUT} < 2.3V$		-	<span style="border: 1px solid black; padding: 0 2px;">0.800</span>	
			$2.3V \leq V_{OUT} < 3.0V$		0.400	<span style="border: 1px solid black; padding: 0 2px;">0.580</span>	
			$3.0V \leq V_{OUT} < 4.0V$		0.300	<span style="border: 1px solid black; padding: 0 2px;">0.480</span>	
			$4.0V \leq V_{OUT} \leq 6.5V$		0.250	<span style="border: 1px solid black; padding: 0 2px;">0.400</span>	
$I_{SS}$	Supply Current	$I_{OUT} = 0mA$		23	<span style="border: 1px solid black; padding: 0 2px;">40</span>	$\mu A$	
$I_{standby}$	Standby Current	$V_{IN} = 10.0V$ , $V_{CE} = GND$		0.1	1.0	$\mu A$	
$\Delta V_{OUT}/\Delta V_{IN}$	Line Regulation	Set $V_{OUT} + 0.5V \leq V_{IN} \leq 10.0V$ (In case that $V_{OUT} \leq 2.1V$ , $2.6V \leq V_{IN} \leq 10.0V$ )		$\pm 0.02$	<span style="border: 1px solid black; padding: 0 2px;"><math>\pm 0.2</math></span>	%/V	
RR	Ripple Rejection	$f = 1kHz$ , Ripple 0.2Vp-p, $I_{OUT} = 30mA$ (In case that $V_{OUT} < 2.0V$ , $V_{IN} = 3.0V$ )		70		dB	
$I_{SC}$	Short Current Limit	$V_{OUT} = 0V$		40		mA	
$I_{PD}$	CE Pull-down Current			0.30		$\mu A$	
$V_{CEH}$	CE Input Voltage "H"		<span style="border: 1px solid black; padding: 0 2px;">1.7</span>			V	
$V_{CEL}$	CE Input Voltage "L"				<span style="border: 1px solid black; padding: 0 2px;">0.8</span>	V	
$T_{TSD}$	Thermal Shutdown Temperature	Junction Temperature		165		$^{\circ}C$	
$T_{TSR}$	Thermal Shutdown Released Temperature	Junction Temperature		110		$^{\circ}C$	
en	Output Noise	$BW = 10Hz$ to $100kHz$		100		$\mu V_{rms}$	
$R_{LOW}$	Low Output Nch Tr. ON Resistance (of D version)	$V_{IN} = 7.0V$ $V_{CE} = 0V$		250		$\Omega$	

All of unit are tested and specified under load conditions such that  $T_j \approx T_a = 25^{\circ}C$  except for Output Noise, Ripple Rejection and Thermal Shutdown.

**RP171x**

No. EA-245-200219

**Product-specific Electrical Characteristics**The specifications surrounded by   are guaranteed by design engineering at  $-40^{\circ}\text{C} \leq T_a \leq 85^{\circ}\text{C}$ .**RP171xxxxB/D**

(Ta = 25°C)

Product Name	V <sub>OUT</sub> [V] (Ta = 25°C)			V <sub>OUT</sub> [V] (Ta = -40 to 85°C)			V <sub>DIF</sub> [V]	
	MIN.	TYP.	MAX.	MIN.	TYP.	MAX.	TYP.	MAX.
RP171x12xx	1.185	1.2	1.215	<span style="border: 1px solid black; padding: 0 2px;">1.160</span>	1.2	<span style="border: 1px solid black; padding: 0 2px;">1.235</span>	1.400	<span style="border: 1px solid black; padding: 0 2px;">1.800</span>
RP171x12xx5	1.235	1.25	1.265	<span style="border: 1px solid black; padding: 0 2px;">1.210</span>	1.25	<span style="border: 1px solid black; padding: 0 2px;">1.285</span>		
RP171x13xx	1.285	1.3	1.315	<span style="border: 1px solid black; padding: 0 2px;">1.260</span>	1.3	<span style="border: 1px solid black; padding: 0 2px;">1.335</span>	1.350	<span style="border: 1px solid black; padding: 0 2px;">1.750</span>
RP171x14xx	1.385	1.4	1.415	<span style="border: 1px solid black; padding: 0 2px;">1.360</span>	1.4	<span style="border: 1px solid black; padding: 0 2px;">1.435</span>		
RP171x15xx	1.485	1.5	1.515	<span style="border: 1px solid black; padding: 0 2px;">1.460</span>	1.5	<span style="border: 1px solid black; padding: 0 2px;">1.535</span>	1.200	<span style="border: 1px solid black; padding: 0 2px;">1.550</span>
RP171x16xx	1.584	1.6	1.616	<span style="border: 1px solid black; padding: 0 2px;">1.558</span>	1.6	<span style="border: 1px solid black; padding: 0 2px;">1.637</span>		
RP171x17xx	1.683	1.7	1.717	<span style="border: 1px solid black; padding: 0 2px;">1.656</span>	1.7	<span style="border: 1px solid black; padding: 0 2px;">1.739</span>		
RP171x18xx	1.782	1.8	1.818	<span style="border: 1px solid black; padding: 0 2px;">1.753</span>	1.8	<span style="border: 1px solid black; padding: 0 2px;">1.841</span>	0.980	<span style="border: 1px solid black; padding: 0 2px;">1.300</span>
RP171x18xx5	1.832	1.85	1.869	<span style="border: 1px solid black; padding: 0 2px;">1.802</span>	1.85	<span style="border: 1px solid black; padding: 0 2px;">1.893</span>		
RP171x19xx	1.881	1.9	1.919	<span style="border: 1px solid black; padding: 0 2px;">1.851</span>	1.9	<span style="border: 1px solid black; padding: 0 2px;">1.944</span>		
RP171x20xx	1.980	2.0	2.020	<span style="border: 1px solid black; padding: 0 2px;">1.948</span>	2.0	<span style="border: 1px solid black; padding: 0 2px;">2.046</span>		
RP171x21xx	2.079	2.1	2.121	<span style="border: 1px solid black; padding: 0 2px;">2.045</span>	2.1	<span style="border: 1px solid black; padding: 0 2px;">2.148</span>		
RP171x22xx	2.178	2.2	2.222	<span style="border: 1px solid black; padding: 0 2px;">2.143</span>	2.2	<span style="border: 1px solid black; padding: 0 2px;">2.251</span>	0.770	<span style="border: 1px solid black; padding: 0 2px;">1.080</span>
RP171x23xx	2.277	2.3	2.323	<span style="border: 1px solid black; padding: 0 2px;">2.240</span>	2.3	<span style="border: 1px solid black; padding: 0 2px;">2.353</span>		
RP171x24xx	2.376	2.4	2.424	<span style="border: 1px solid black; padding: 0 2px;">2.338</span>	2.4	<span style="border: 1px solid black; padding: 0 2px;">2.455</span>		
RP171x25xx	2.475	2.5	2.525	<span style="border: 1px solid black; padding: 0 2px;">2.435</span>	2.5	<span style="border: 1px solid black; padding: 0 2px;">2.558</span>		
RP171x26xx	2.574	2.6	2.626	<span style="border: 1px solid black; padding: 0 2px;">2.532</span>	2.6	<span style="border: 1px solid black; padding: 0 2px;">2.660</span>		
RP171x27xx	2.673	2.7	2.727	<span style="border: 1px solid black; padding: 0 2px;">2.630</span>	2.7	<span style="border: 1px solid black; padding: 0 2px;">2.762</span>		
RP171x28xx	2.772	2.8	2.828	<span style="border: 1px solid black; padding: 0 2px;">2.727</span>	2.8	<span style="border: 1px solid black; padding: 0 2px;">2.864</span>		
RP171x28xx5	2.822	2.85	2.879	<span style="border: 1px solid black; padding: 0 2px;">2.776</span>	2.85	<span style="border: 1px solid black; padding: 0 2px;">2.916</span>	0.600	<span style="border: 1px solid black; padding: 0 2px;">0.850</span>
RP171x29xx	2.871	2.9	2.929	<span style="border: 1px solid black; padding: 0 2px;">2.825</span>	2.9	<span style="border: 1px solid black; padding: 0 2px;">2.967</span>		
RP171x30xx	2.970	3.0	3.030	<span style="border: 1px solid black; padding: 0 2px;">2.922</span>	3.0	<span style="border: 1px solid black; padding: 0 2px;">3.069</span>		
RP171x31xx	3.069	3.1	3.131	<span style="border: 1px solid black; padding: 0 2px;">3.019</span>	3.1	<span style="border: 1px solid black; padding: 0 2px;">3.171</span>		
RP171x32xx	3.168	3.2	3.232	<span style="border: 1px solid black; padding: 0 2px;">3.117</span>	3.2	<span style="border: 1px solid black; padding: 0 2px;">3.274</span>		
RP171x33xx	3.267	3.3	3.333	<span style="border: 1px solid black; padding: 0 2px;">3.214</span>	3.3	<span style="border: 1px solid black; padding: 0 2px;">3.376</span>		
RP171x34xx	3.366	3.4	3.434	<span style="border: 1px solid black; padding: 0 2px;">3.312</span>	3.4	<span style="border: 1px solid black; padding: 0 2px;">3.478</span>		
RP171x35xx	3.465	3.5	3.535	<span style="border: 1px solid black; padding: 0 2px;">3.409</span>	3.5	<span style="border: 1px solid black; padding: 0 2px;">3.581</span>		
RP171x36xx	3.564	3.6	3.636	<span style="border: 1px solid black; padding: 0 2px;">3.506</span>	3.6	<span style="border: 1px solid black; padding: 0 2px;">3.683</span>		
RP171x37xx	3.663	3.7	3.737	<span style="border: 1px solid black; padding: 0 2px;">3.604</span>	3.7	<span style="border: 1px solid black; padding: 0 2px;">3.785</span>		
RP171x38xx	3.762	3.8	3.838	<span style="border: 1px solid black; padding: 0 2px;">3.701</span>	3.8	<span style="border: 1px solid black; padding: 0 2px;">3.887</span>		
RP171x39xx	3.861	3.9	3.939	<span style="border: 1px solid black; padding: 0 2px;">3.799</span>	3.9	<span style="border: 1px solid black; padding: 0 2px;">3.990</span>		

**Product-specific Electrical Characteristics**

The specifications surrounded by   are guaranteed by design engineering at  $-40^{\circ}\text{C} \leq T_a \leq 85^{\circ}\text{C}$ .

RP171xxxxB/D

( $T_a = 25^{\circ}\text{C}$ )

Product Name	V <sub>OUT</sub> [V] ( $T_a = 25^{\circ}\text{C}$ )			V <sub>OUT</sub> [V] ( $T_a = -40$ to $85^{\circ}\text{C}$ )			V <sub>DIF</sub> [V]	
	MIN.	TYP.	MAX.	MIN.	TYP.	MAX.	TYP.	MAX.
RP171x40xx	3.960	4.0	4.040	<span style="border: 1px solid black; padding: 0 2px;">3.896</span>	4.0	<span style="border: 1px solid black; padding: 0 2px;">4.092</span>	0.500	<span style="border: 1px solid black; padding: 0 2px;">0.750</span>
RP171x41xx	4.059	4.1	4.141	<span style="border: 1px solid black; padding: 0 2px;">3.993</span>	4.1	<span style="border: 1px solid black; padding: 0 2px;">4.194</span>		
RP171x42xx	4.158	4.2	4.242	<span style="border: 1px solid black; padding: 0 2px;">4.091</span>	4.2	<span style="border: 1px solid black; padding: 0 2px;">4.297</span>		
RP171x43xx	4.257	4.3	4.343	<span style="border: 1px solid black; padding: 0 2px;">4.188</span>	4.3	<span style="border: 1px solid black; padding: 0 2px;">4.399</span>		
RP171x44xx	4.356	4.4	4.444	<span style="border: 1px solid black; padding: 0 2px;">4.286</span>	4.4	<span style="border: 1px solid black; padding: 0 2px;">4.501</span>		
RP171x45xx	4.455	4.5	4.545	<span style="border: 1px solid black; padding: 0 2px;">4.383</span>	4.5	<span style="border: 1px solid black; padding: 0 2px;">4.604</span>		
RP171x46xx	4.554	4.6	4.646	<span style="border: 1px solid black; padding: 0 2px;">4.480</span>	4.6	<span style="border: 1px solid black; padding: 0 2px;">4.706</span>		
RP171x47xx	4.653	4.7	4.747	<span style="border: 1px solid black; padding: 0 2px;">4.578</span>	4.7	<span style="border: 1px solid black; padding: 0 2px;">4.808</span>		
RP171x48xx	4.752	4.8	4.848	<span style="border: 1px solid black; padding: 0 2px;">4.675</span>	4.8	<span style="border: 1px solid black; padding: 0 2px;">4.910</span>		
RP171x49xx	4.851	4.9	4.949	<span style="border: 1px solid black; padding: 0 2px;">4.773</span>	4.9	<span style="border: 1px solid black; padding: 0 2px;">5.013</span>		
RP171x50xx	4.950	5.0	5.050	<span style="border: 1px solid black; padding: 0 2px;">4.870</span>	5.0	<span style="border: 1px solid black; padding: 0 2px;">5.115</span>		
RP171x51xx	5.049	5.1	5.151	<span style="border: 1px solid black; padding: 0 2px;">4.967</span>	5.1	<span style="border: 1px solid black; padding: 0 2px;">5.217</span>		
RP171x52xx	5.148	5.2	5.252	<span style="border: 1px solid black; padding: 0 2px;">5.065</span>	5.2	<span style="border: 1px solid black; padding: 0 2px;">5.320</span>		
RP171x53xx	5.247	5.3	5.353	<span style="border: 1px solid black; padding: 0 2px;">5.162</span>	5.3	<span style="border: 1px solid black; padding: 0 2px;">5.422</span>		
RP171x54xx	5.346	5.4	5.454	<span style="border: 1px solid black; padding: 0 2px;">5.260</span>	5.4	<span style="border: 1px solid black; padding: 0 2px;">5.524</span>		
RP171x55xx	5.445	5.5	5.555	<span style="border: 1px solid black; padding: 0 2px;">5.357</span>	5.5	<span style="border: 1px solid black; padding: 0 2px;">5.627</span>		
RP171x56xx	5.544	5.6	5.656	<span style="border: 1px solid black; padding: 0 2px;">5.454</span>	5.6	<span style="border: 1px solid black; padding: 0 2px;">5.729</span>		
RP171x57xx	5.643	5.7	5.757	<span style="border: 1px solid black; padding: 0 2px;">5.552</span>	5.7	<span style="border: 1px solid black; padding: 0 2px;">5.831</span>		
RP171x58xx	5.742	5.8	5.858	<span style="border: 1px solid black; padding: 0 2px;">5.649</span>	5.8	<span style="border: 1px solid black; padding: 0 2px;">5.933</span>		
RP171x59xx	5.841	5.9	5.959	<span style="border: 1px solid black; padding: 0 2px;">5.747</span>	5.9	<span style="border: 1px solid black; padding: 0 2px;">6.036</span>		
RP171x60xx	5.940	6.0	6.060	<span style="border: 1px solid black; padding: 0 2px;">5.844</span>	6.0	<span style="border: 1px solid black; padding: 0 2px;">6.138</span>		
RP171x61xx	6.039	6.1	6.161	<span style="border: 1px solid black; padding: 0 2px;">5.941</span>	6.1	<span style="border: 1px solid black; padding: 0 2px;">6.240</span>		
RP171x62xx	6.138	6.2	6.262	<span style="border: 1px solid black; padding: 0 2px;">6.039</span>	6.2	<span style="border: 1px solid black; padding: 0 2px;">6.343</span>		
RP171x63xx	6.237	6.3	6.363	<span style="border: 1px solid black; padding: 0 2px;">6.136</span>	6.3	<span style="border: 1px solid black; padding: 0 2px;">6.445</span>		
RP171x64xx	6.336	6.4	6.464	<span style="border: 1px solid black; padding: 0 2px;">6.234</span>	6.4	<span style="border: 1px solid black; padding: 0 2px;">6.547</span>		
RP171x65xx	6.435	6.5	6.565	<span style="border: 1px solid black; padding: 0 2px;">6.331</span>	6.5	<span style="border: 1px solid black; padding: 0 2px;">6.650</span>		

---

## RP171x

---

No. EA-245-200219

## APPLICATION INFORMATION

### TYPICAL APPLICATION

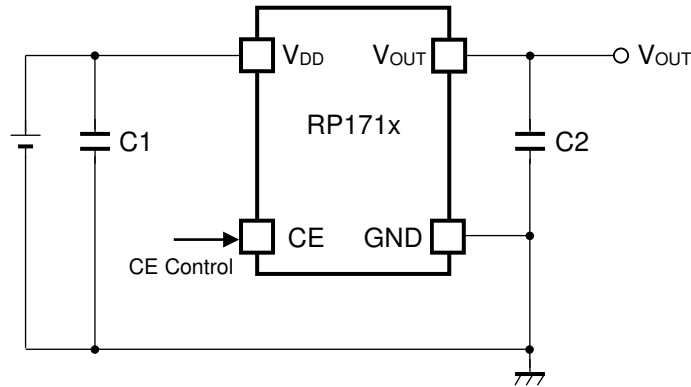

(External Components)

C2 1.0 $\mu$ F MURATA: GRM155B31A105KE15

### Phase Compensation

In these ICs, phase compensation is made for securing stable operation even if the load current is varied. For this purpose, use a capacitor C2 with 1.0 $\mu$ F or more and good ESR (Equivalent Series Resistance).

(Note: If additional ceramic capacitors are connected with parallel to the output pin with an output capacitor for phase compensation, the operation might be unstable. Because of this, test these ICs with as same external components as ones to be used on the PCB.)

### PCB Layout

Make V<sub>DD</sub> and GND lines sufficient. If their impedance is high, noise pickup or unstable operation may result. Connect a capacitor C1 with a capacitance value as much as 1.0 $\mu$ F or more between V<sub>DD</sub> and GND pin, and as close as possible to the pins.

Set external components, especially the output capacitor C2, as close as possible to the ICs, and make wiring as short as possible.



**ESR vs. Output Current**

When using these ICs, consider the following points:

The relations between  $I_{OUT}$  (Output Current) and ESR of an output capacitor are shown below.  
 The conditions when the white noise level is under  $40\mu V$  (Avg.) are marked as the hatched area in the graph.

Measurement conditions

Frequency Band : 10Hz to 2MHz

Temperature :  $-40^{\circ}C$  to  $85^{\circ}C$

C1, C2 : Ceramic  $1.0\mu F$  (Murata GRM155B31A105KE)

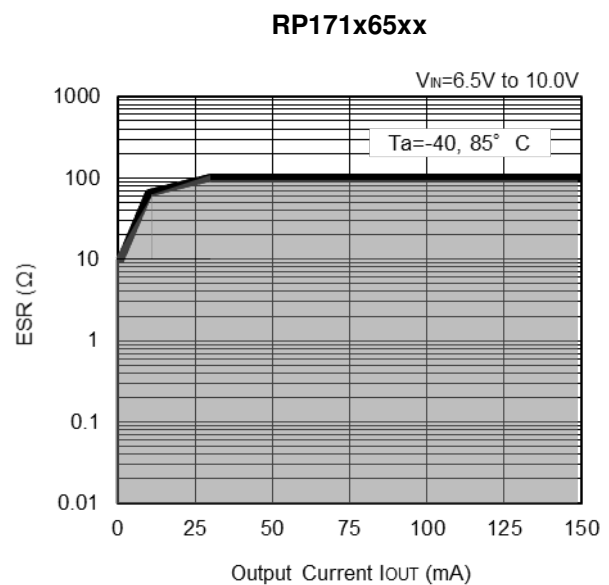
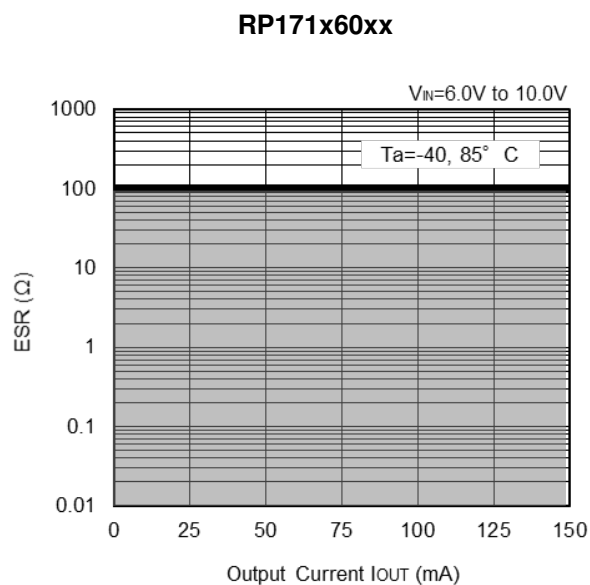
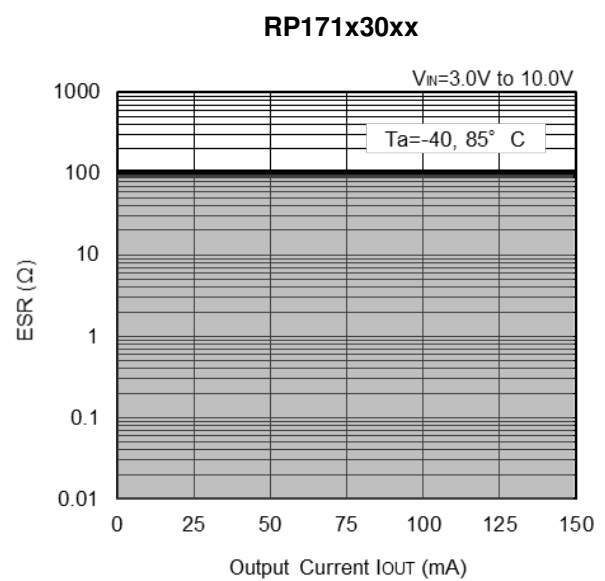
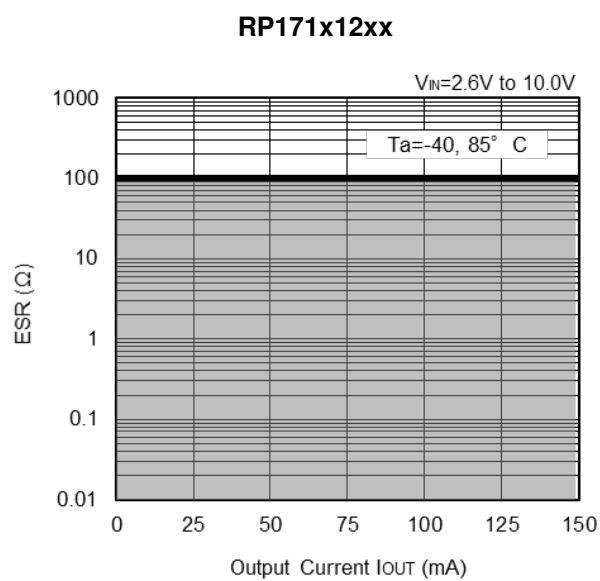

# RP171x

No. EA-245-200219

## TYPICAL CHARACTERISTICS

Note: Typical Characteristics are intended to be used as reference data; they are not guaranteed.

### 1) Output Voltage vs. Output Current (Ta = 25°C)

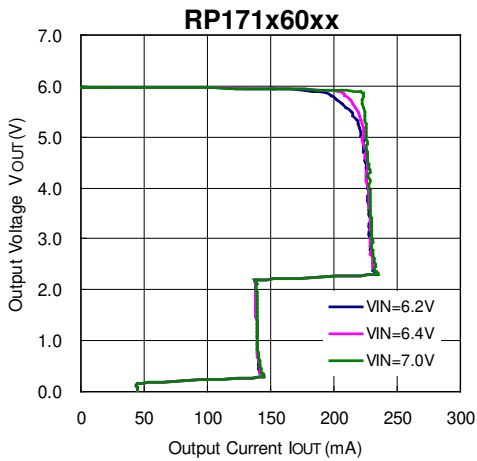
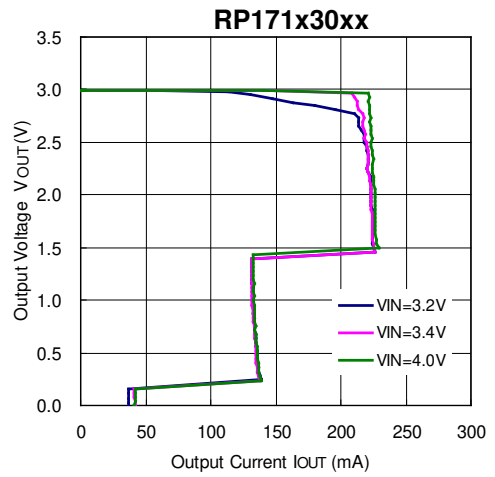
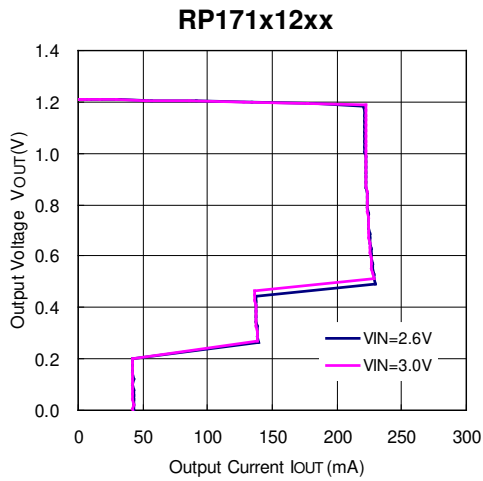

### 2) Output Voltage vs. Input Voltage (Ta = 25°C)

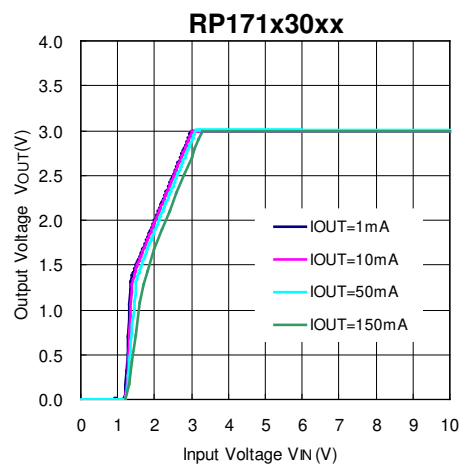
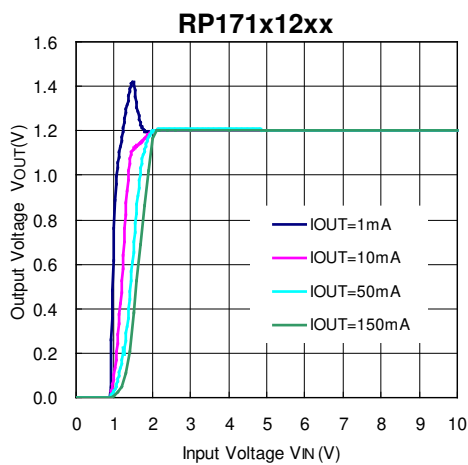

RP171x60xx

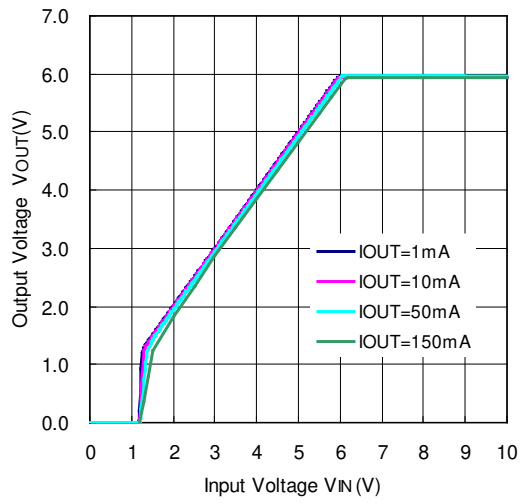

3) Supply Current vs. Input Voltage (Ta = 25°C)

RP171x12xx

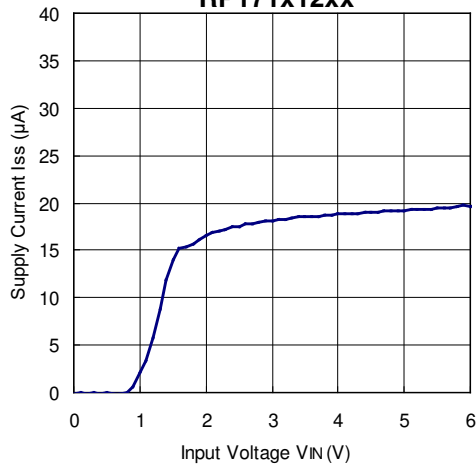

RP171x30xx

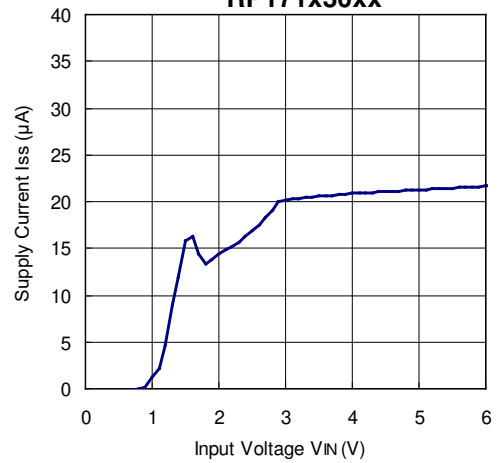

RP171x60xx

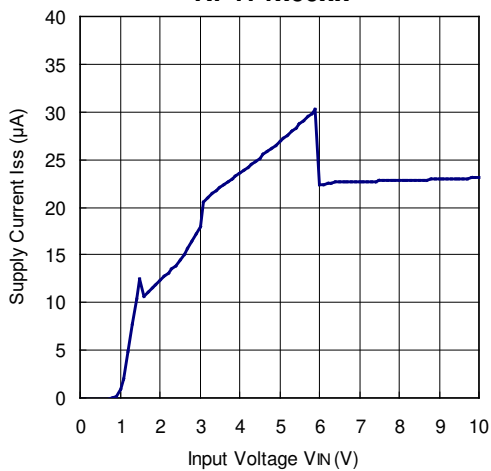

---

## RP171x

---

No. EA-245-200219

### 4) Supply Current vs. Output Current ( $T_a = 25^\circ\text{C}$ )

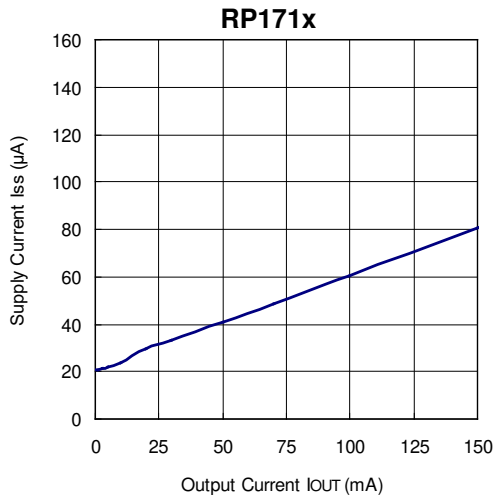

### 5) Output Voltage vs. Temperature

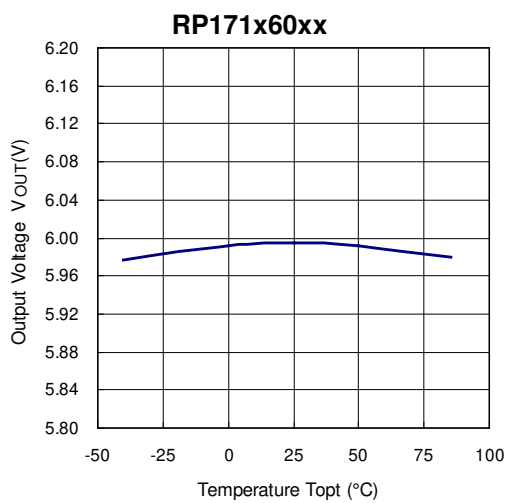
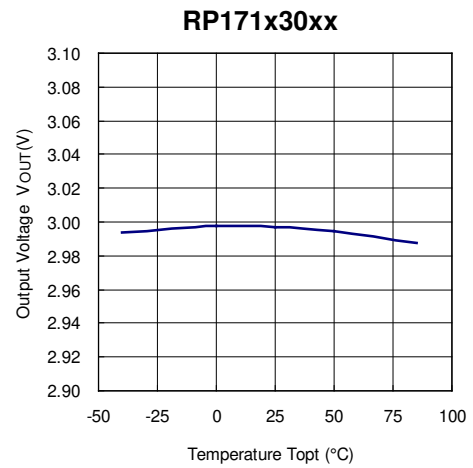
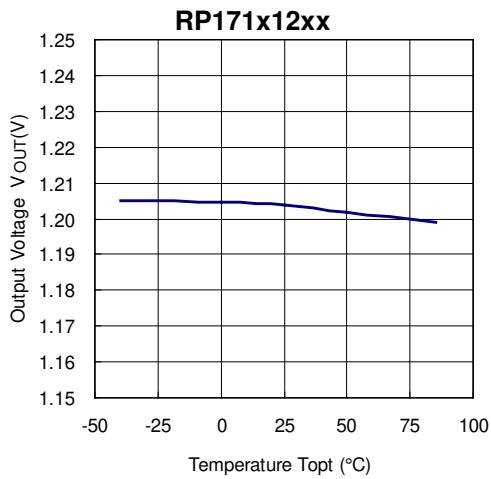

6) Supply Current vs. Temperature

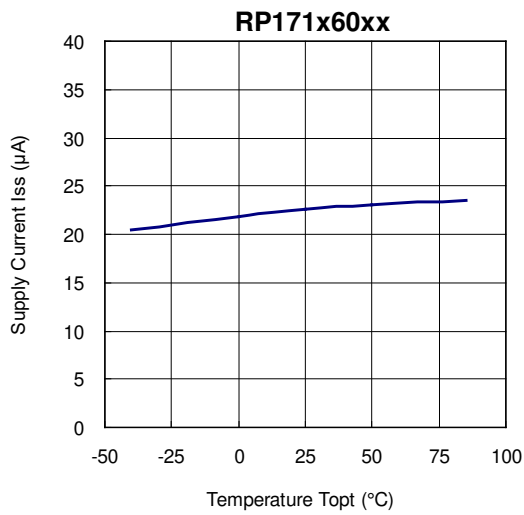
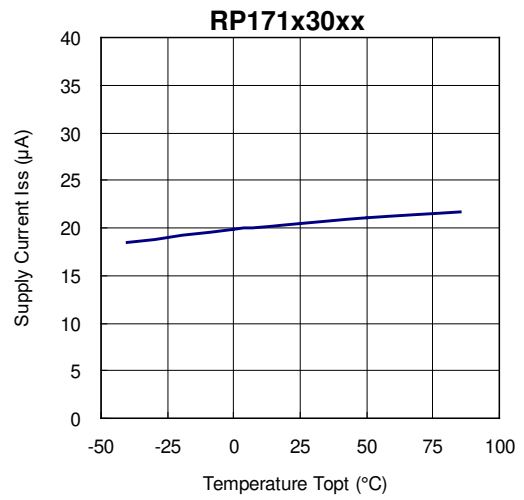
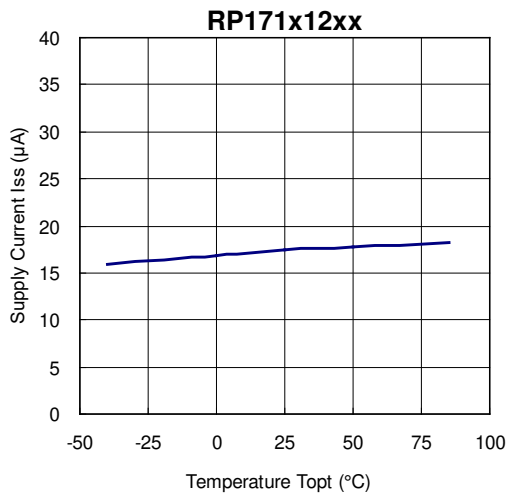

7) Dropout Voltage vs. Output Current

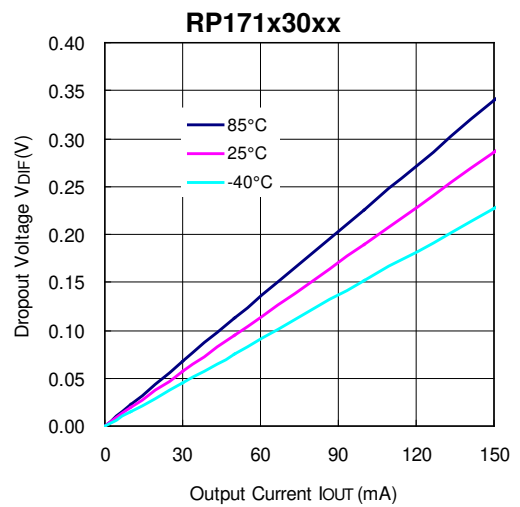
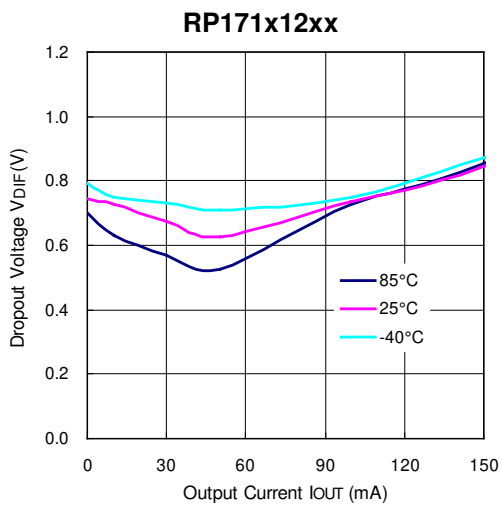

---

# RP171x

---

No. EA-245-200219

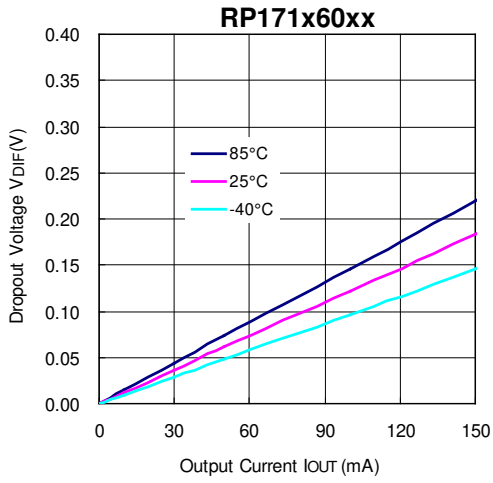

## 8) Dropout Voltage vs. Set Output Voltage (Ta = 25°C) RP171x

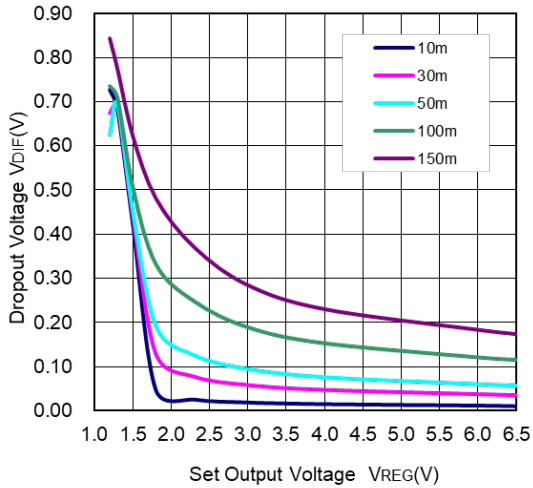

## 9) Minimum Operating Voltage RP171x12xx

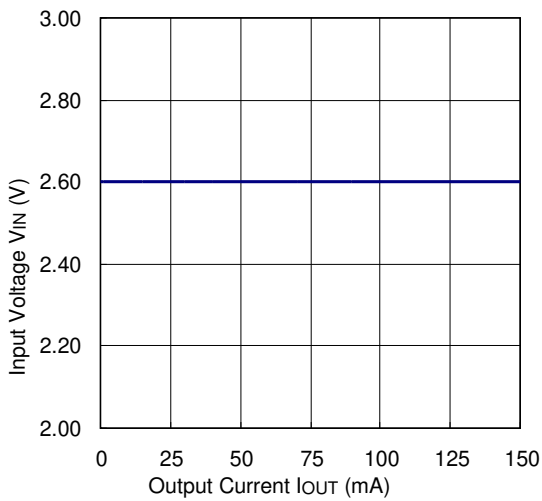

10) Ripple Rejection vs. Input Bias Voltage (C1=none, C2=Ceramic 1.0μF, Ripple=0.2Vp-p, Ta = 25°C)

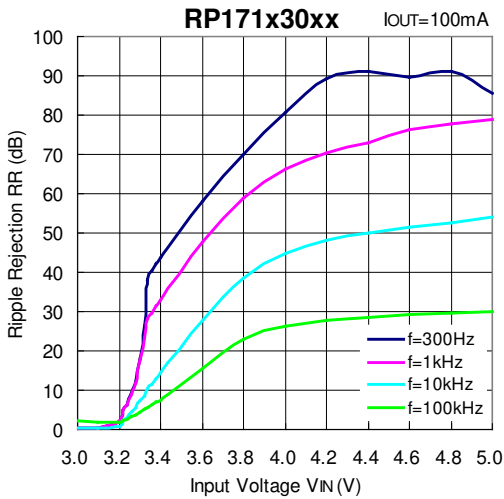
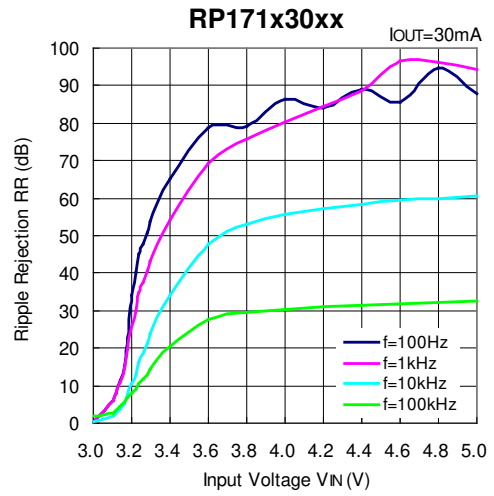
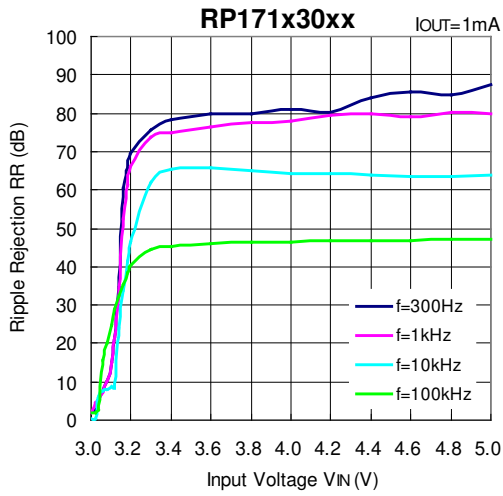

11) Ripple Rejection vs. Frequency (C1=none, C2=Ceramic 1.0μF, Ta=25°C)

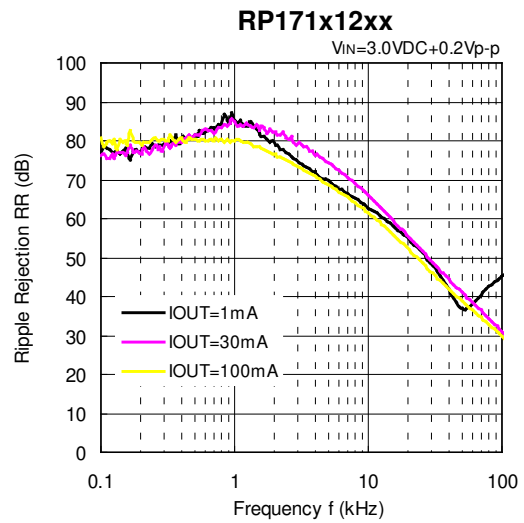
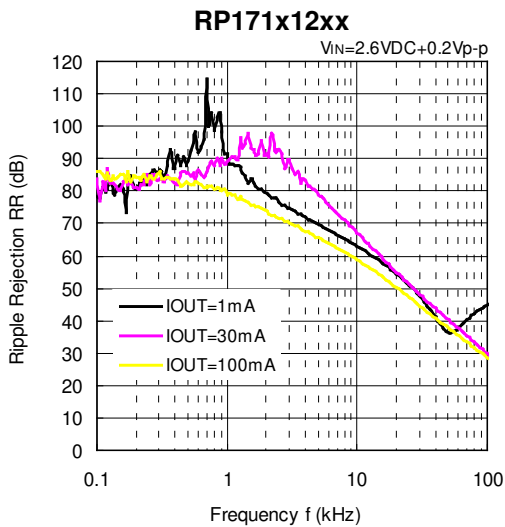

# RP171x

No. EA-245-200219

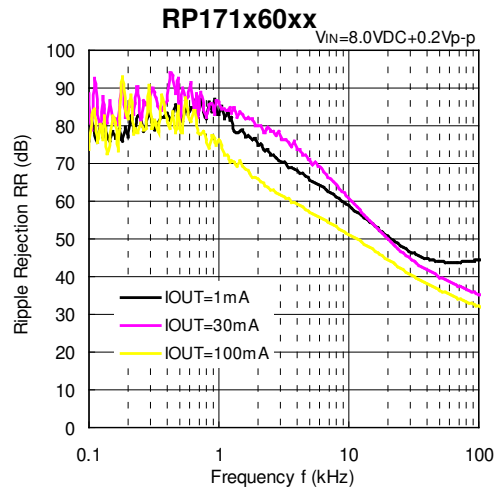
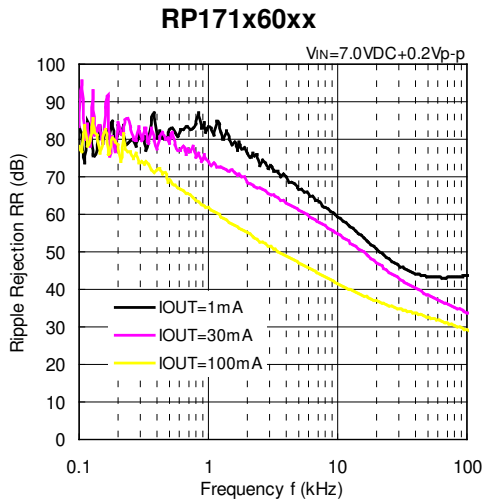
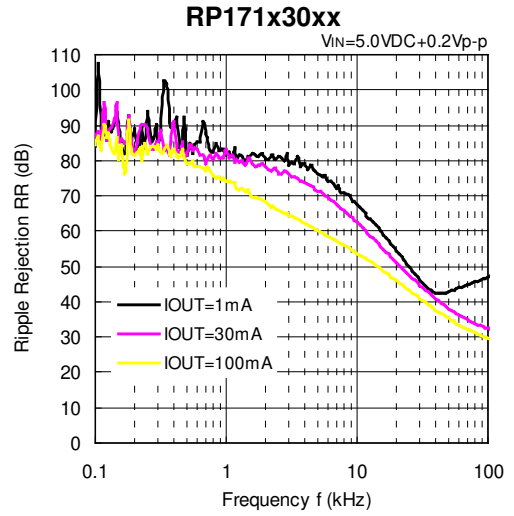
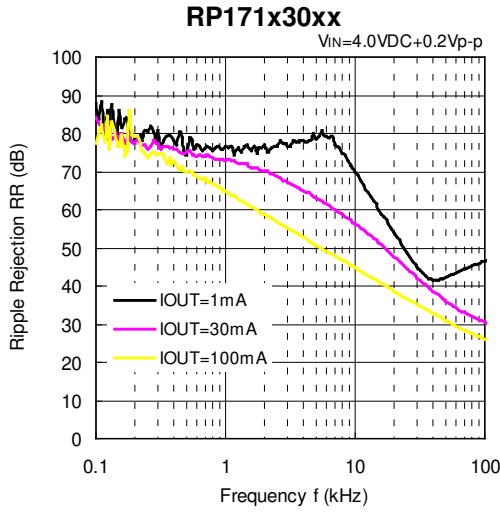

## 12) Input Transient Response (C1=none, IOUT=30mA, tr=tf=5μs, Ta=25°C)

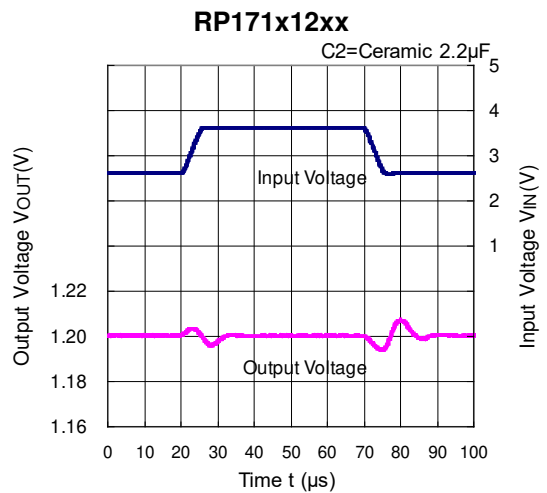
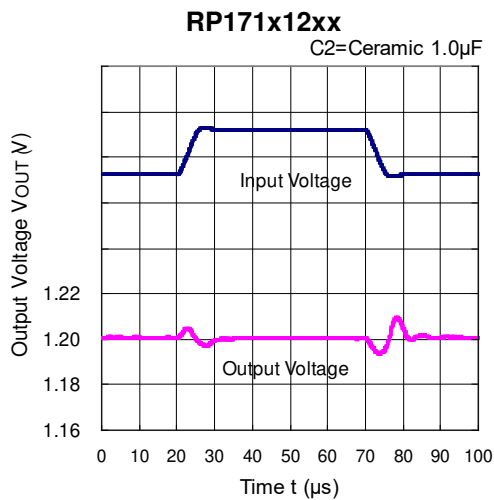



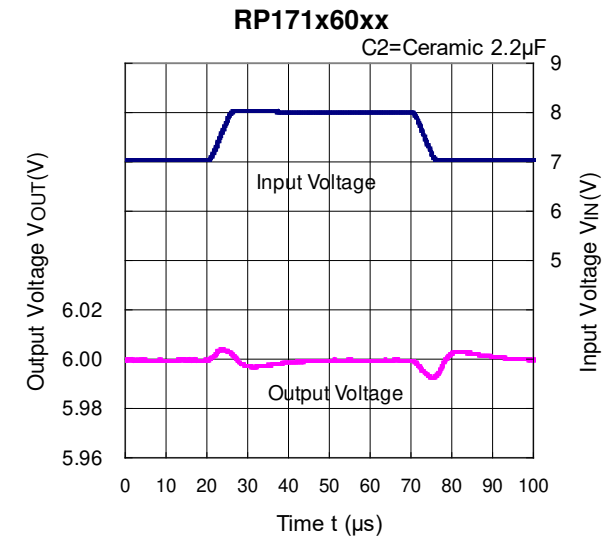
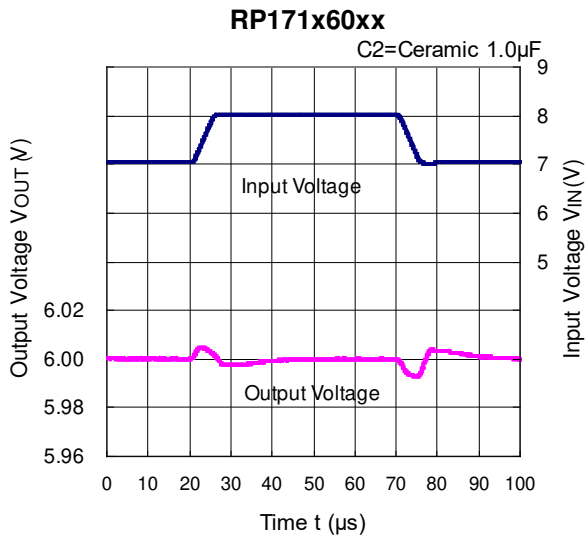
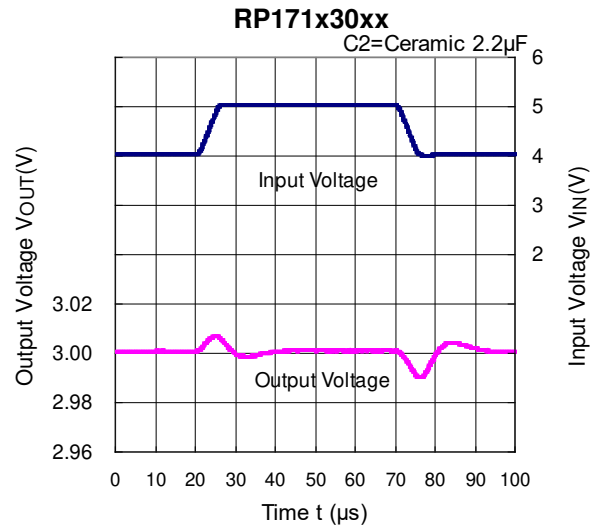
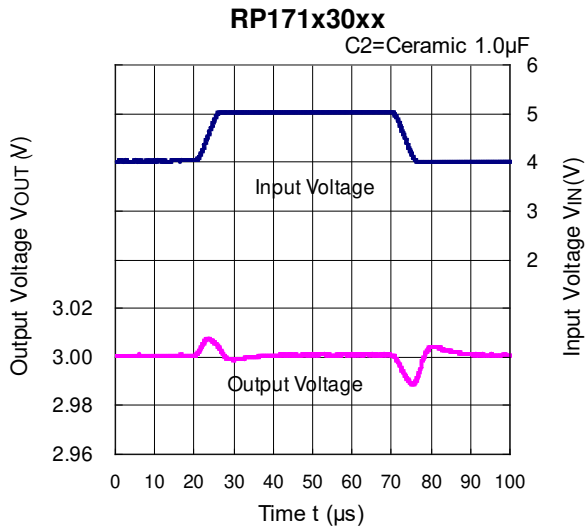

13) Load Transient Response (C1=Ceramic 1.0 $\mu$ F,  $t_r=t_f=500ns$ ,  $T_a=25^\circ C$ )

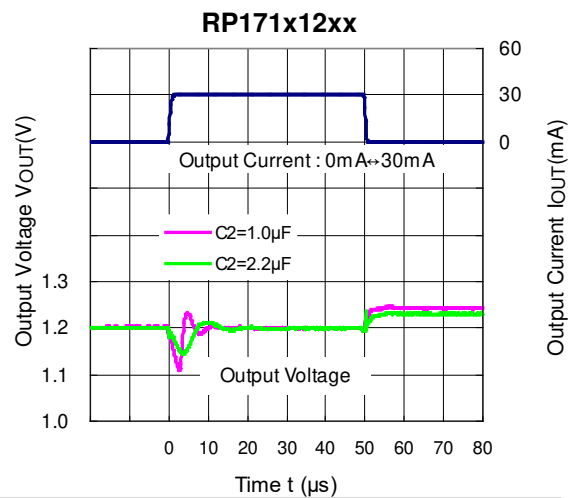
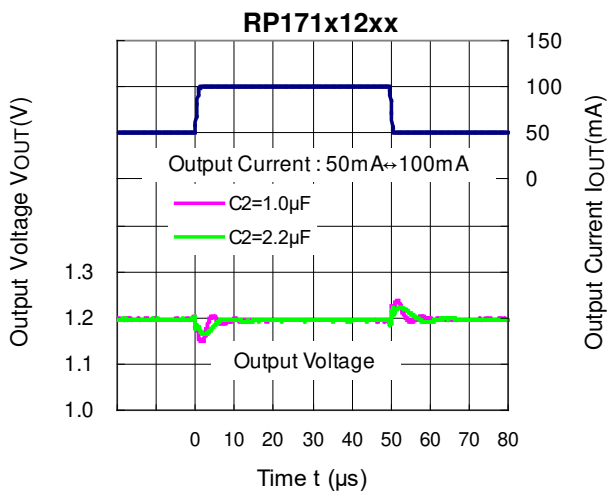

# RP171x

No. EA-245-200219

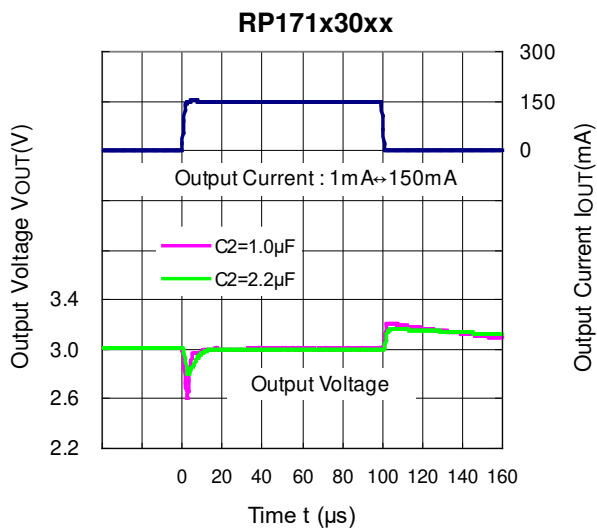
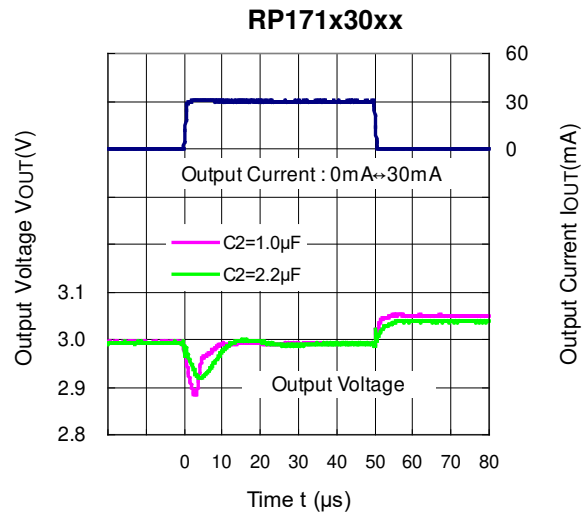
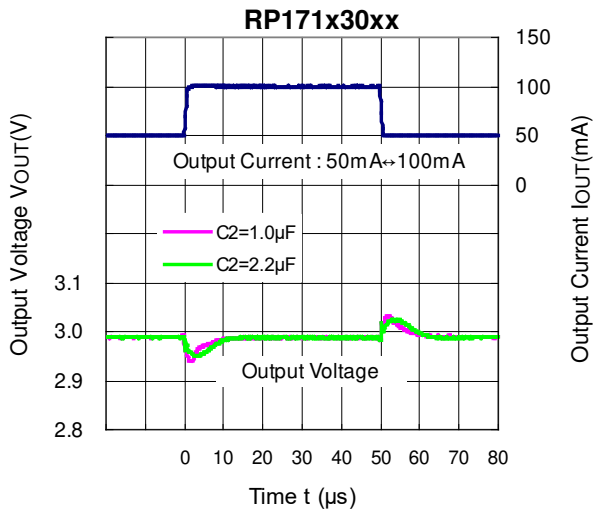
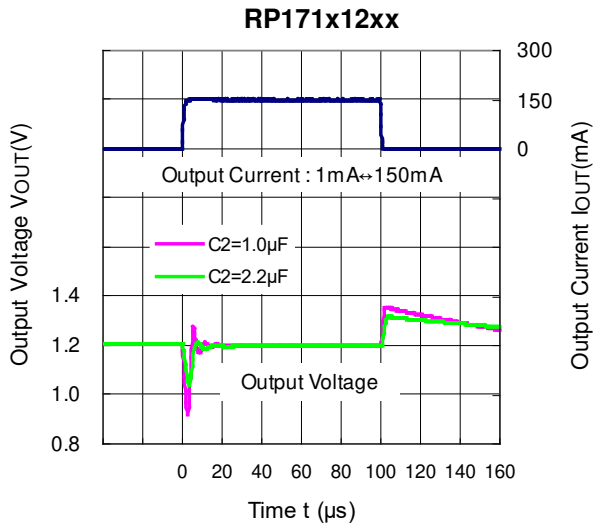

RP171x60xx

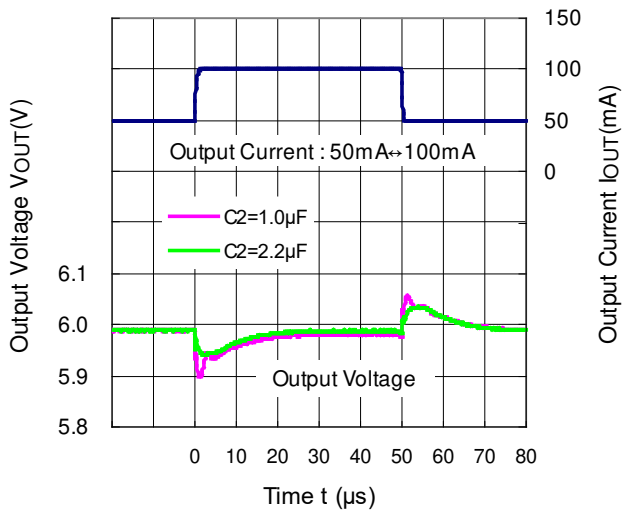

RP171x60xx

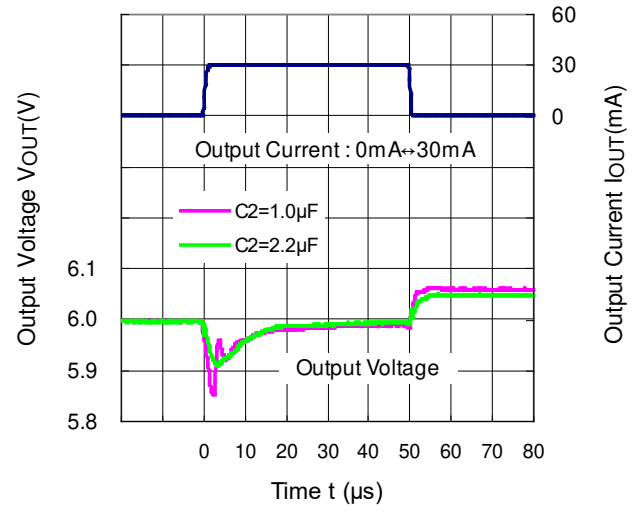

RP171x60xx

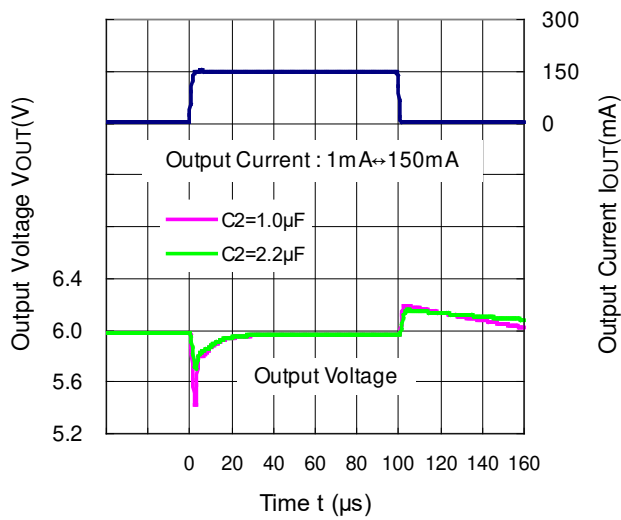

# RP171x

No. EA-245-200219

## 14) Turn On Speed with CE pin (C1=Ceramic 1.0 $\mu$ F, Ta=25°C)

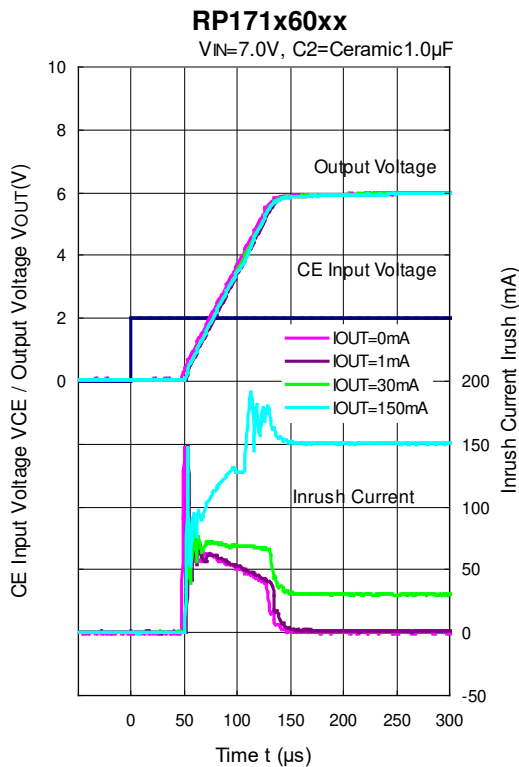
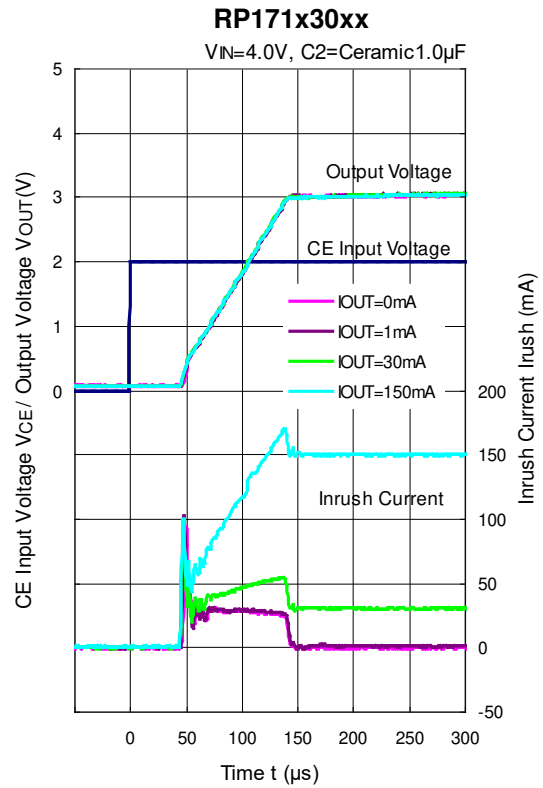
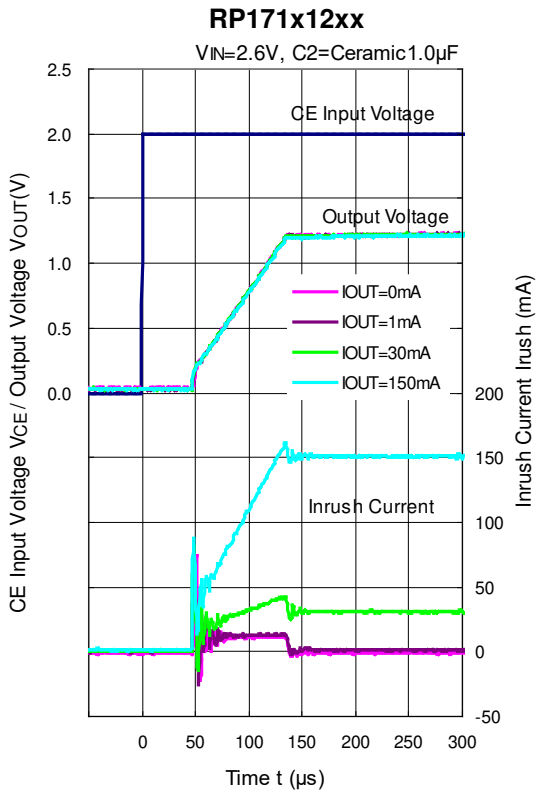

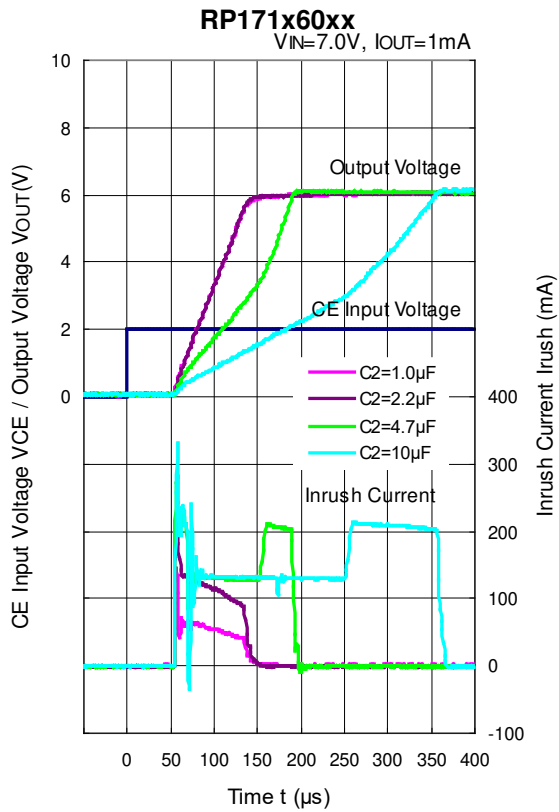
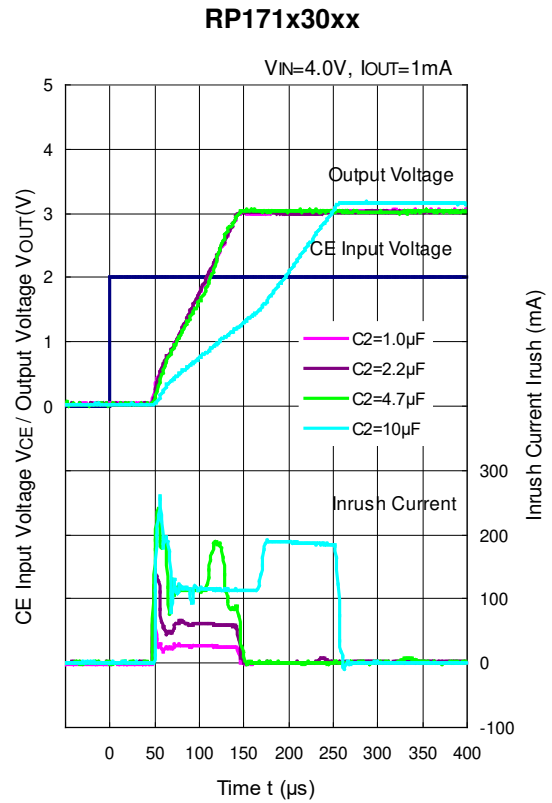
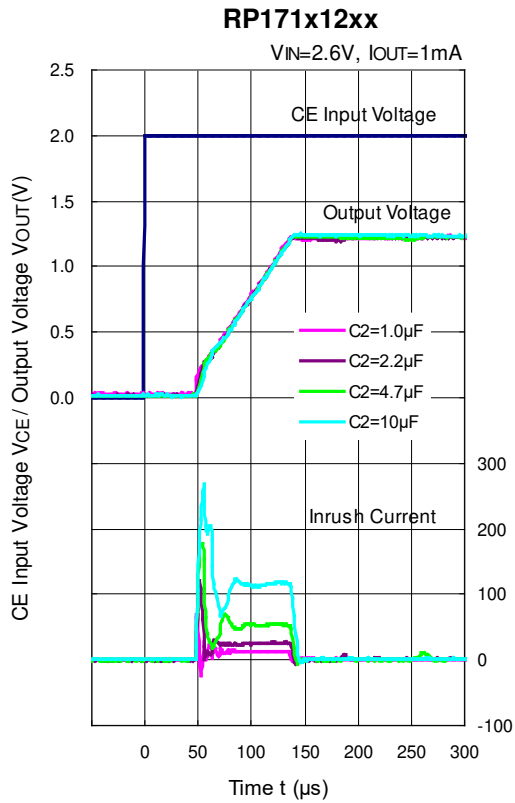

# RP171x

No. EA-245-200219

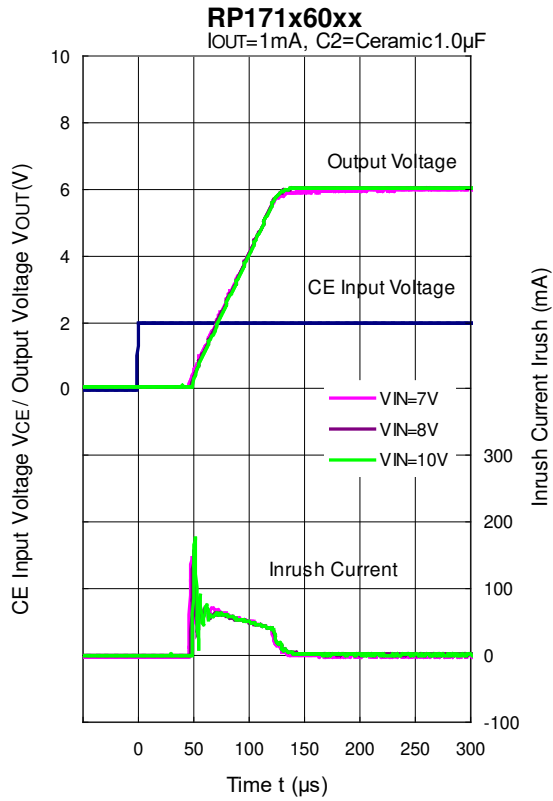
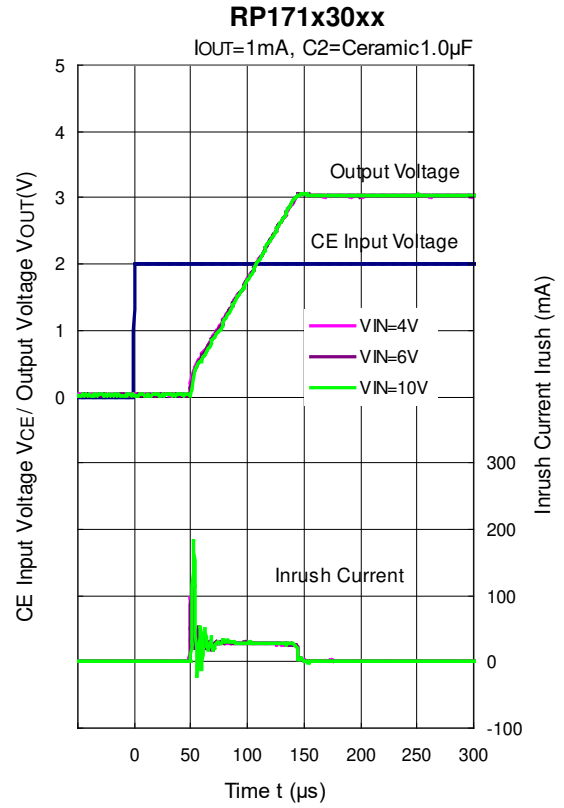
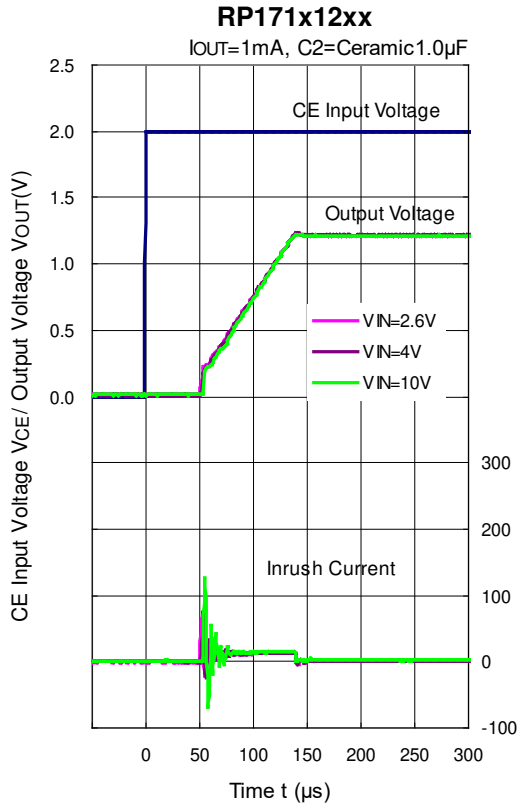

15) Turn Off Speed with CE pin (D Version) (C1=Ceramic 1.0 $\mu$ F, Ta=25°C)

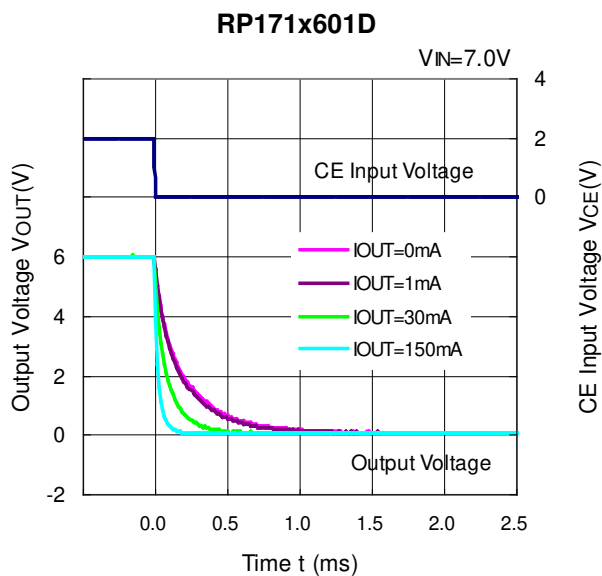
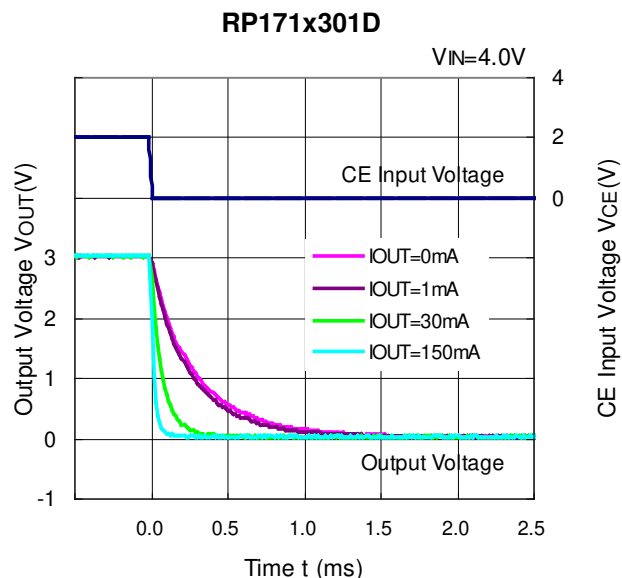
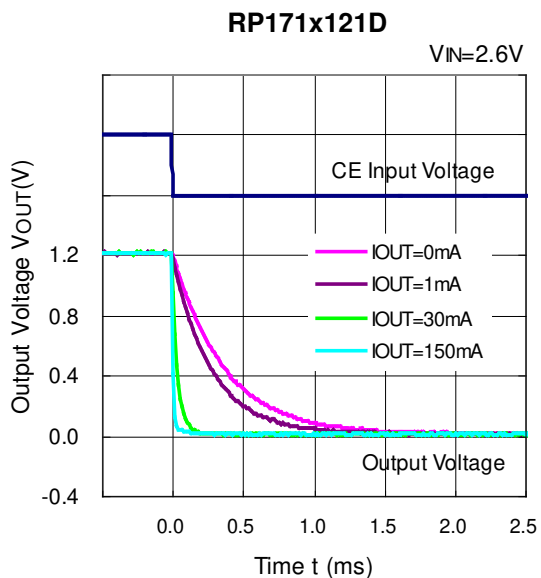

The power dissipation of the package is dependent on PCB material, layout, and environmental conditions. The following conditions are used in this measurement.

**Measurement Conditions**

Item	Standard Test Land Pattern
Environment	Mounting on Board (Wind Velocity = 0 m/s)
Board Material	Glass Cloth Epoxy Plastic (Double-Sided Board)
Board Dimensions	40 mm × 40 mm × 1.6 mm
Copper Ratio	Top Side: Approx. 50% Bottom Side: Approx. 50%
Through-holes	φ 0.5 mm × 44 pcs

**Measurement Result**

(Ta = 25°C, Tjmax = 125°C)

Item	Standard Test Land Pattern
Power Dissipation	380 mW
Thermal Resistance (θja)	θja = 263°C/W
Thermal Characterization Parameter (ψjt)	ψjt = 75°C/W

θja: Junction-to-Ambient Thermal Resistance

ψjt: Junction-to-Top Thermal Characterization Parameter

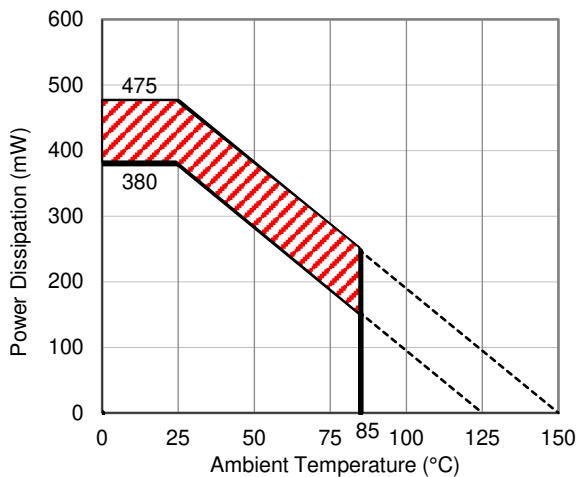

**Power Dissipation vs. Ambient Temperature**

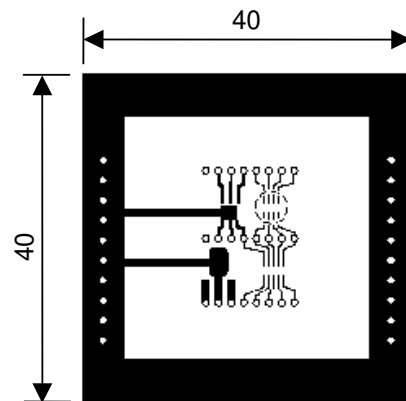

**Measurement Board Pattern**

The above graph shows the power dissipation of the package at Tjmax = 125°C and Tjmax = 150°C. Operating the device in the hatched range might have a negative influence on its lifetime. The total hours of use and the total years of use must be limited as follows:

Total Hours of Use	Total Years of Use (4 hours/day)
13,000 hours	9 years



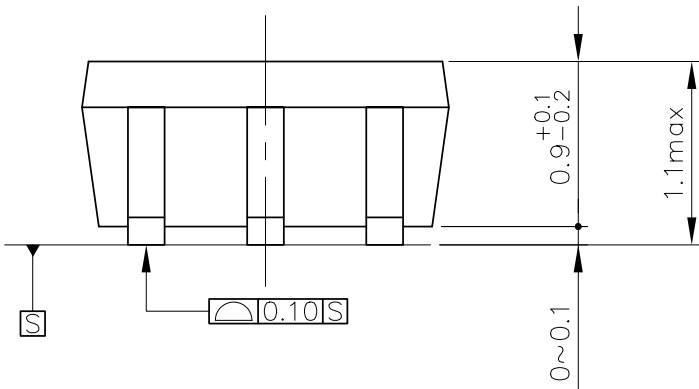
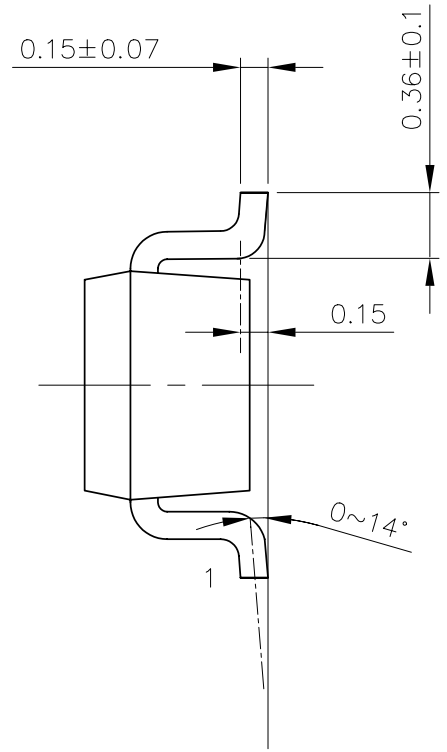
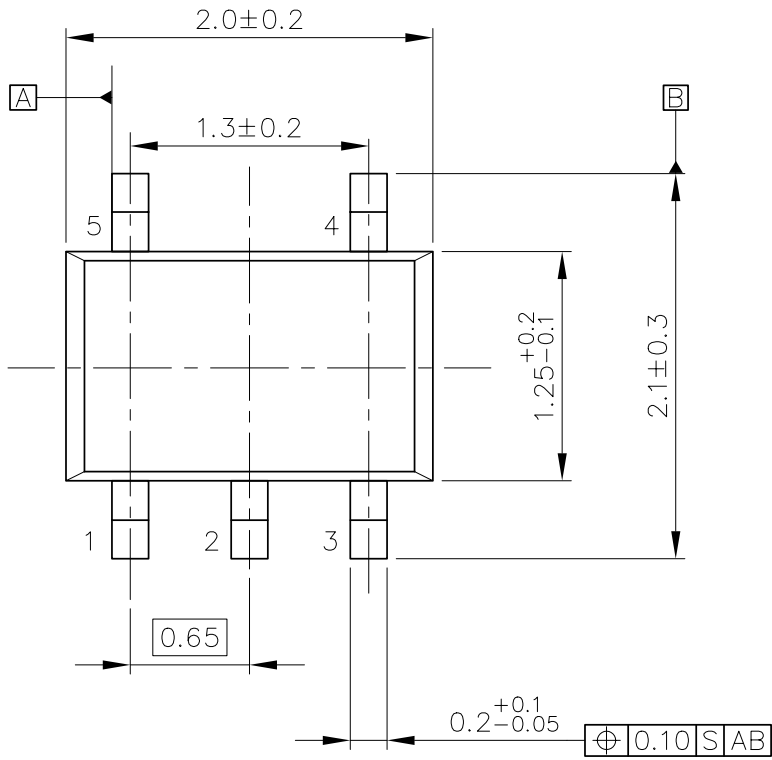

UNIT: mm

SC-88A Package Dimensions

The power dissipation of the package is dependent on PCB material, layout, and environmental conditions. The following measurement conditions are based on JEDEC STD. 51-7.

**Measurement Conditions**

Item	Measurement Conditions
Environment	Mounting on Board (Wind Velocity = 0 m/s)
Board Material	Glass Cloth Epoxy Plastic (Four-Layer Board)
Board Dimensions	76.2 mm × 114.3 mm × 0.8 mm
Copper Ratio	Outer Layer (First Layer): Less than 95% of 50 mm Square Inner Layers (Second and Third Layers): Approx. 100% of 50 mm Square Outer Layer (Fourth Layer): Approx. 100% of 50 mm Square
Through-holes	φ 0.3 mm × 7 pcs

**Measurement Result**

(Ta = 25°C, Tjmax = 125°C)

Item	Measurement Result
Power Dissipation	660 mW
Thermal Resistance (θja)	θja = 150°C/W
Thermal Characterization Parameter (ψjt)	ψjt = 51°C/W

θja: Junction-to-Ambient Thermal Resistance

ψjt: Junction-to-Top Thermal Characterization Parameter

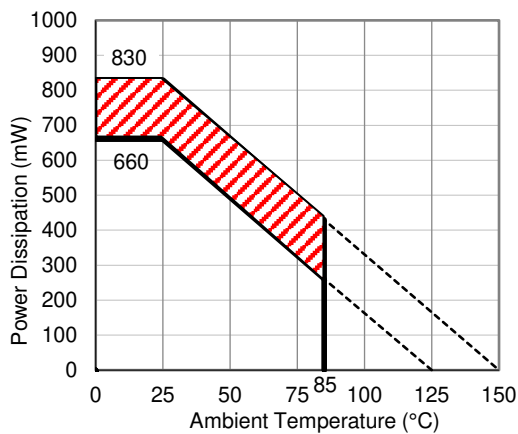

**Power Dissipation vs. Ambient Temperature**

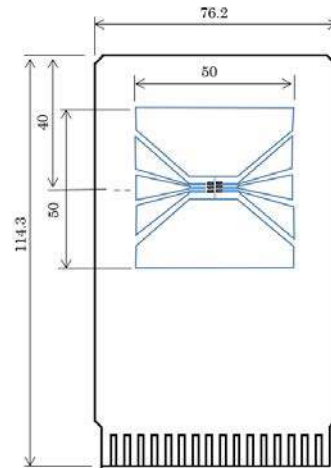

**Measurement Board Pattern**

The above graph shows the power dissipation of the package at Tjmax = 125°C and Tjmax = 150°C. Operating the device in the hatched range might have a negative influence on its lifetime. The total hours of use and the total years of use must be limited as follows:

Total Hours of Use	Total Years of Use (4 hours/day)
13,000 hours	9 years

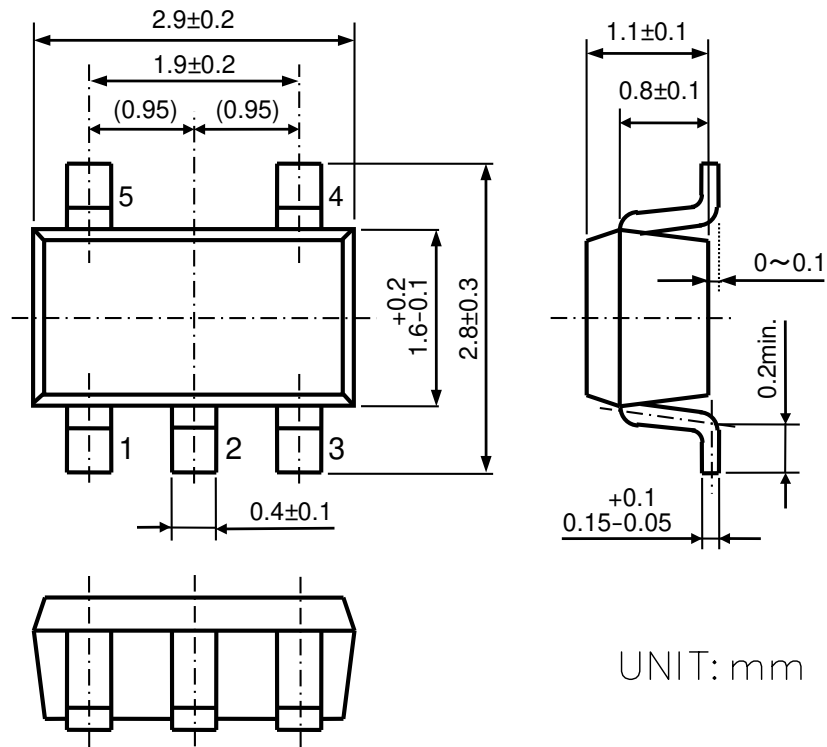

UNIT: mm

SOT-23-5 Package Dimensions



1. The products and the product specifications described in this document are subject to change or discontinuation of production without notice for reasons such as improvement. Therefore, before deciding to use the products, please refer to our sales representatives for the latest information thereon.
2. The materials in this document may not be copied or otherwise reproduced in whole or in part without prior written consent of our company.
3. Please be sure to take any necessary formalities under relevant laws or regulations before exporting or otherwise taking out of your country the products or the technical information described herein.
4. The technical information described in this document shows typical characteristics of and example application circuits for the products. The release of such information is not to be construed as a warranty of or a grant of license under our company's or any third party's intellectual property rights or any other rights.
5. The products listed in this document are intended and designed for use as general electronic components in standard applications (office equipment, telecommunication equipment, measuring instruments, consumer electronic products, amusement equipment etc.). Those customers intending to use a product in an application requiring extreme quality and reliability, for example, in a highly specific application where the failure or misoperation of the product could result in human injury or death (aircraft, spacevehicle, nuclear reactor control system, traffic control system, automotive and transportation equipment, combustion equipment, safety devices, life support system etc.) should first contact us.
6. We are making our continuous effort to improve the quality and reliability of our products, but semiconductor products are likely to fail with certain probability. In order to prevent any injury to persons or damages to property resulting from such failure, customers should be careful enough to incorporate safety measures in their design, such as redundancy feature, fire containment feature and fail-safe feature. We do not assume any liability or responsibility for any loss or damage arising from misuse or inappropriate use of the products.
7. Anti-radiation design is not implemented in the products described in this document.
8. The X-ray exposure can influence functions and characteristics of the products. Confirm the product functions and characteristics in the evaluation stage.
9. WLCSP products should be used in light shielded environments. The light exposure can influence functions and characteristics of the products under operation or storage.
10. There can be variation in the marking when different AOI (Automated Optical Inspection) equipment is used. In the case of recognizing the marking characteristic with AOI, please contact our sales or our distributor before attempting to use AOI.
11. Please contact our sales representatives should you have any questions or comments concerning the products or the technical information.



**Nisshinbo Micro Devices Inc.**

**Official website**

<https://www.nisshinbo-microdevices.co.jp/en/>

**Purchase information**

<https://www.nisshinbo-microdevices.co.jp/en/buy/>

