

#### Absolute maximum ratings

( $T_a=25^\circ\text{C}$ )

Symbol	Ratings	Unit
$V_{CBO}$	120	V
$V_{CEO}$	120	V
$V_{EBO}$	6	V
$I_c$	5	A
$I_{CP}$	8 ( $PW \leq 1\text{ms}$ , $D_u \leq 50\%$ )	A
$I_B$	0.5	A
$I_F$	5 ( $PW \leq 0.5\text{ms}$ , $D_u \leq 25\%$ )	A
$I_{FSM}$	8 ( $PW \leq 10\text{ms}$ , single)	A
$V_R$	120	V
$P_T$	5 ( $T_a=25^\circ\text{C}$ )	W
	25 ( $T_c=25^\circ\text{C}$ )	
$V_{ISO}$	1000 (Between fin and lead pin, AC)	$V_{rms}$
$T_j$	150	$^\circ\text{C}$
$T_{stg}$	-40 to +150	$^\circ\text{C}$
$\theta_{j-c}$	5	$^\circ\text{C}/\text{W}$

#### Electrical characteristics

( $T_a=25^\circ\text{C}$ )

Symbol	Specification			Unit	Conditions
	min	typ	max		
$I_{CBO}$			10	$\mu\text{A}$	$V_{CB}=120\text{V}$
$I_{EBO}$			10	mA	$V_{EB}=6\text{V}$
$V_{CEO}$	120			V	$I_c=25\text{mA}$
$h_{FE}$	2000	5000	15000		$V_{CE}=2\text{V}$ , $I_c=3\text{A}$
$V_{CE(sat)}$		1.0	1.5	V	$I_c=3\text{A}$ , $I_B=3\text{mA}$
$V_{BE(sat)}$		1.6	2.0	V	
$t_{on}$		0.5		$\mu\text{s}$	$V_{CC} \approx 30\text{V}$ , $I_c=3\text{A}$ , $I_{B1}=-I_{B2}=3\text{mA}$
$t_{stg}$		5.5		$\mu\text{s}$	
$t_f$		1.5		$\mu\text{s}$	

#### Diode for flyback voltage absorption

( $T_a=25^\circ\text{C}$ )

Symbol	Specification			Unit	Conditions
	min	typ	max		
$V_R$	120			V	$I_R=10\mu\text{A}$
$V_F$			1.2	V	$I_F=1\text{A}$
$I_R$			10	$\mu\text{A}$	$V_R=120\text{V}$
$t_{rr}$		100		ns	$I_F=\pm 100\text{mA}$

#### Equivalent circuit diagram

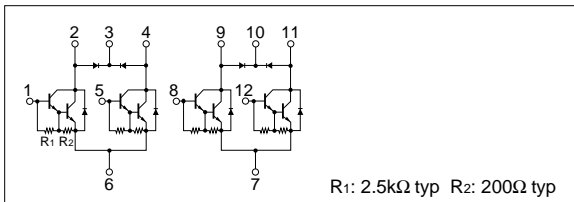

#### Characteristic curves

$I_c$ - $V_{CE}$  Characteristics (Typical)

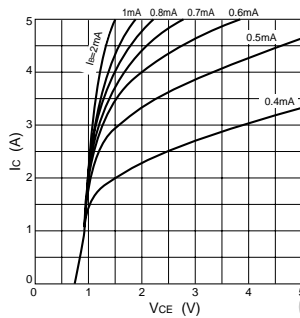

$h_{FE}$ - $I_c$  Characteristics (Typical)

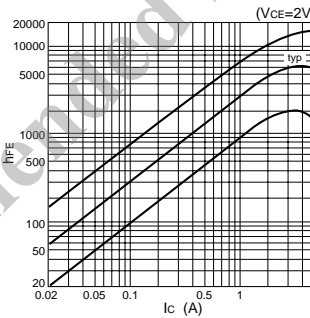

$h_{FE}$ - $I_c$  Temperature Characteristics (Typical)

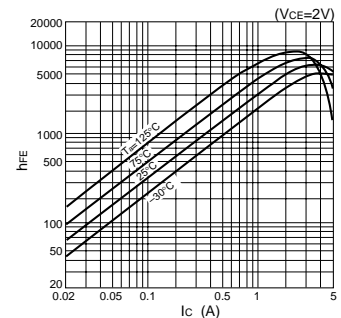

$V_{CE(sat)}$ - $I_c$  Temperature Characteristics (Typical)

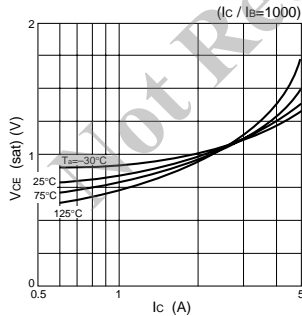

$V_{CE(sat)}$ - $I_B$  Characteristics (Typical)

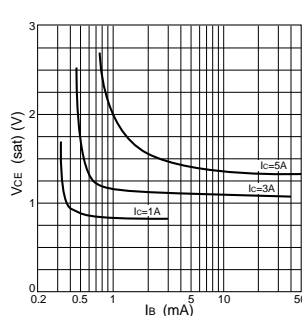

$I_c$ - $V_{BE}$  Temperature Characteristics (Typical)

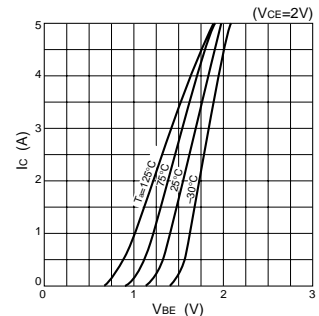

$\theta_{j-a}$ - $PW$  Characteristics

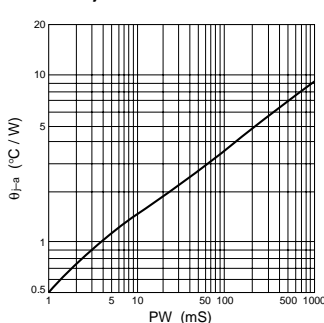

$P_T$ - $T_a$  Characteristics

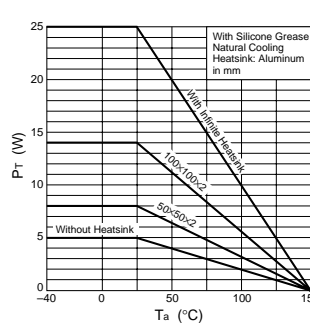

Safe Operating Area (SOA)

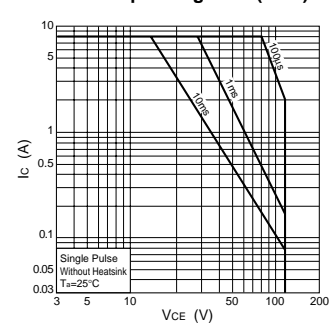

• SIP 8 (STA8Pin)

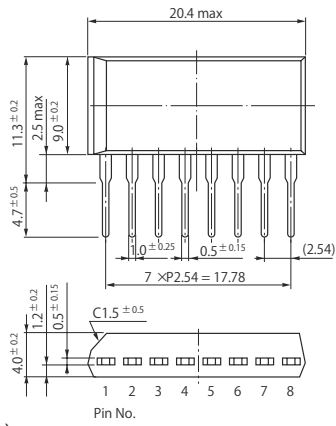

• SIP 10 (STA10Pin)

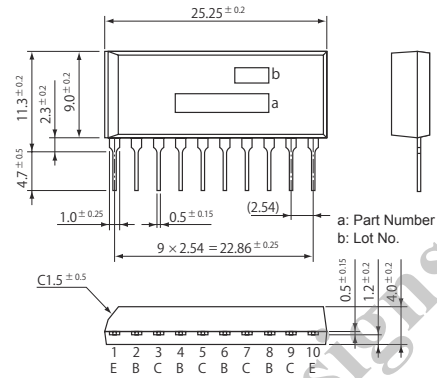

• SIP 12 (SMA12Pin)

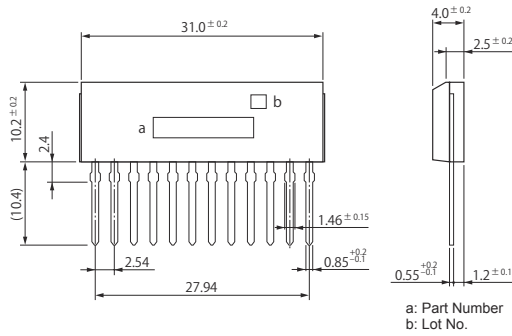

• SIP 15 (SMA15Pin)

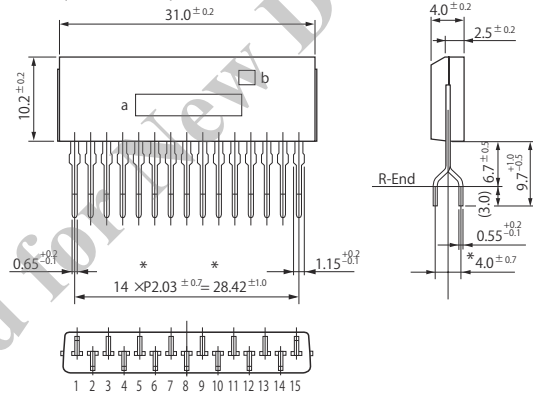

• SIP 12 with Fin (SLA12Pin)

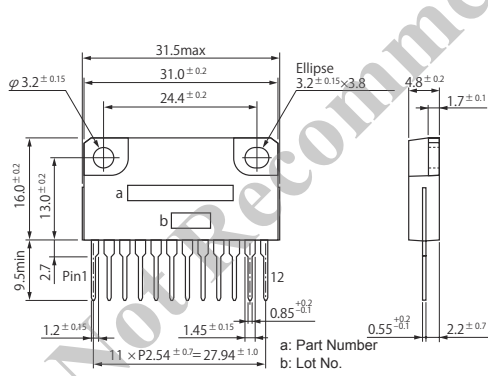

• SIP 15 with Fin (SLA15Pin)

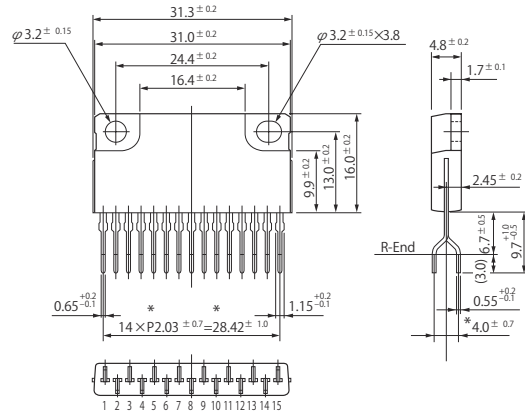

• SIP 21 with Fin (SLA21Pin)

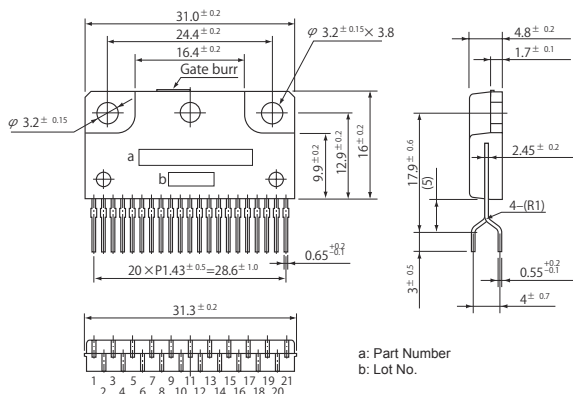

(Unit:mm)