



MAX-M10S

Standard precision GNSS module

Professional grade

Data sheet



Abstract

This data sheet describes the MAX-M10S module, an ultra-low-power GNSS receiver for high-performance asset-tracking applications.

www.u-blox.com

UBX-20035208 - R04
C1-Public



Document information

Title	MAX-M10S	
Subtitle	Standard precision GNSS module	
Document type	Data sheet	
Document number	UBX-20035208	
Revision and date	R04	16-May-2023
Disclosure restriction	C1-Public	

Product status	Corresponding content status	
Functional Sample	Draft	For functional testing. Revised and supplementary data will be published later.
In development / prototype	Objective specification	Target values. Revised and supplementary data will be published later.
Engineering sample	Advance information	Data based on early testing. Revised and supplementary data will be published later.
Initial production	Early production information	Data from product verification. Revised and supplementary data may be published later.
Mass production / End of life	Production information	Document contains the final product specification.

This document applies to the following products:

Product name	Type number	FW version	IN/PCN reference	Product status
MAX-M10S	MAX-M10S-00B-01	ROM SPG 5.10	UBX-22012689	Initial production

u-blox or third parties may hold intellectual property rights in the products, names, logos and designs included in this document. Copying, reproduction, or modification of this document or any part thereof is only permitted with the express written permission of u-blox. Disclosure to third parties is permitted for clearly public documents only.

The information contained herein is provided "as is" and u-blox assumes no liability for its use. No warranty, either express or implied, is given, including but not limited to, with respect to the accuracy, correctness, reliability and fitness for a particular purpose of the information. This document may be revised by u-blox at any time without notice. For the most recent documents, visit www.u-blox.com.

Copyright © 2023, u-blox AG.

Contents

1 Functional description.....	4
1.1 Overview.....	4
1.2 Performance.....	4
1.3 Supported GNSS constellations.....	5
1.4 Supported protocols.....	6
1.5 Firmware features.....	6
2 System description.....	8
2.1 Block diagram.....	8
3 Pin definition.....	9
3.1 Pin assignment.....	9
3.2 Pin state.....	10
4 Electrical specifications.....	11
4.1 Absolute maximum ratings.....	11
4.2 Operating conditions.....	11
4.3 Indicative power requirements.....	12
5 Communication interfaces.....	15
5.1 UART.....	15
5.2 I2C.....	15
5.3 Default interface settings.....	15
6 Mechanical specifications.....	16
7 Approvals.....	17
8 Product handling.....	18
8.1 Moisture sensitivity level.....	18
9 Labeling and ordering information.....	19
9.1 Product labeling.....	19
9.2 Explanation of product codes.....	19
9.3 Ordering codes.....	19
Related documents.....	21
Revision history.....	22

1 Functional description

1.1 Overview

MAX-M10S module features the u-blox M10 standard precision GNSS platform and provides exceptional sensitivity and acquisition time for all L1 GNSS signals.

The M10 platform supports concurrent reception of four GNSS (GPS, GLONASS, Galileo, and BeiDou). The high number of visible satellites enables the receiver to select the best signals. This maximizes the position availability, in particular under challenging conditions such as in deep urban canyons.

u-blox Super-S (Super-Signal) technology offers great RF sensitivity and can improve the dynamic position accuracy with small antennas or in non-line-of-sight scenarios.

The extremely low power consumption of 25 mW in continuous tracking mode allows great power autonomy for all battery-operated devices, such as asset trackers, without compromising on GNSS performance.

For maximum sensitivity in passive antenna designs, MAX-M10S integrates an LNA followed by a SAW filter in the RF path.

MAX-M10S offers backwards pin-to-pin compatibility with products from the previous u-blox generations, which saves the designer's effort and reduces costs when upgrading designs to the advanced low-power u-blox M10 GNSS technology.

1.2 Performance

Parameter	Specification	Value
Receiver type		u-blox M10 receiver
Accuracy of time pulse signal	RMS	30 ns
	99%	60 ns
Frequency of time pulse signal		Default 1PPS (0.25 Hz to 10 MHz configurable)
Operational limits ¹	Dynamics	≤ 4 g
	Altitude	80,000 m
	Velocity	500 m/s
Velocity accuracy ²		0.05 m/s
Dynamic heading accuracy ²		0.3 deg

Table 1: MAX-M10S specifications

Parameter		GPS+GAL	GPS+GAL +GLO	GPS+GAL +BDS B1I (default)	GPS+GAL +BDS B1C	GPS+GAL +BDS B1C +GLO
		Max navigation update rate ³	Default	10 Hz	6 Hz	3 Hz
	High performance ⁴	20 Hz	16 Hz	12 Hz	16 Hz	10 Hz

¹ Assuming Airborne 4 g platform.

² 50% at 30 m/s for dynamic operation.

³ Minimum 98% fix rate under typical conditions.

⁴ Configuration required.

Parameter		GPS+GAL	GPS+GAL +GLO	GPS+GAL +BDS B1I (default)	GPS+GAL +BDS B1C	GPS+GAL +BDS B1C +GLO
Position accuracy (CEP) ^{5, 6}		1.5 m	1.5 m	1.5 m	1.5 m	1.5 m
Time To First Fix (TTFF) ^{5, 7, 8}	Cold start	28 s	23 s	27 s	28 s	23 s
	Hot start	1 s	1 s	1 s	1 s	1 s
	AssistNow Online ⁹	1 s	1 s	1 s	1 s	1 s
	AssistNow Offline ¹⁰	2 s	2 s	3 s	2 s	2 s
	AssistNow Autonomous ¹¹	3 s	4 s	4 s	4 s	4 s
Sensitivity ¹²	Tracking and nav.	-167 dBm	-167 dBm	-167 dBm	-167 dBm	-167 dBm
	Reacquisition	-160 dBm	-160 dBm	-160 dBm	-160 dBm	-160 dBm
	Cold Start	-148 dBm	-148 dBm	-148 dBm	-148 dBm	-148 dBm
	Hot start ⁷	-159 dBm	-159 dBm	-159 dBm	-159 dBm	-159 dBm

Table 2: MAX-M10S typical performance in multi-constellation GNSS modes.

Parameter		GPS	GLONASS	BDS B1I	GALILEO	BDS B1C
Max navigation update rate ³	Default	18 Hz	18 Hz	18 Hz	18 Hz	18 Hz
	High performance ⁴	25 Hz	25 Hz	25 Hz	25 Hz	25 Hz
Position accuracy (CEP) ^{5, 6}		1.5 m	4 m	2 m	3 m	2 m
Time To First Fix (TTFF) ^{5, 7, 8}	Cold start	29 s	27 s	30 s	41 s	56 s
	Hot start	1 s	1 s	1 s	1 s	1 s
	AssistNow Online ⁹	1 s	1 s	1 s	5 s	N/A
Sensitivity ¹²	Tracking and nav.	-167 dBm	-166 dBm	-160 dBm	-161 dBm	-163 dBm
	Reacquisition	-160 dBm	-158 dBm	-158 dBm	-154 dBm	-156 dBm
	Cold Start	-148 dBm	-147 dBm	-146 dBm	-141 dBm	-136 dBm
	Hot start ⁷	-159 dBm	-159 dBm	-159 dBm	-155 dBm	-157 dBm

Table 3: MAX-M10S typical performance in single-GNSS modes

1.3 Supported GNSS constellations

MAX-M10S is a concurrent GNSS receiver that can receive and track multiple GNSS systems. The single RF front-end architecture enables concurrent reception of multiple GNSS constellations. The receiver can be configured for a subset of GNSS constellations to achieve lower power consumption.

The default configuration on MAX-M10S is concurrent reception of GPS, Galileo, and BeiDou B1I with QZSS and SBAS enabled.

The following GNSS and their signals are supported:

⁵ GPS is always in combination with SBAS and QZSS.

⁶ CEP, 50%, 24 hours static, -130 dBm, > 6 SVs for each GNSS system

⁷ Commanded starts.

⁸ All satellites at -130 dBm. Measured at room temperature.

⁹ Dependent on the speed and latency of the aiding data connection, commanded starts.

¹⁰ Using seven days old AssistNow Offline data. External memory may be required.

¹¹ Using two days old orbital predicted data. External memory may be required.

¹² Demonstrated with a good external LNA. Measured at room temperature.

System	Signals
GPS / QZSS	L1C/A (1575.42 MHz)
Galileo	E1-B/C (1575.42 MHz)
GLONASS	L1OF (1602 MHz + k*562.5 kHz, k = -7,..., 5, 6)
BeiDou ¹³	B1I (1561.098 MHz), B1C (1575.42 MHz)

Table 4: Supported GNSS and signals on MAX-M10S

The following GNSS assistance services are supported:

Service	Support
AssistNow™ Online	GPS L1C/A, QZSS L1C/A, Galileo E1, GLONASS L1OF, BeiDou B1I
AssistNow™ Offline	GPS L1C/A, GLONASS L1OF
AssistNow™ Autonomous	GPS L1C/A, QZSS L1C/A, Galileo E1, GLONASS L1OF, BeiDou B1I

Table 5: Supported Assisted GNSS (A-GNSS) services

The following augmentation systems are supported:

System	Support
SBAS	EGNOS, GAGAN, MSAS and WAAS
QZSS	L1S (SLAS)

Table 6: Supported augmentation systems

The augmentation systems SBAS and QZSS can be enabled only if GPS operation is also enabled.

1.4 Supported protocols

MAX-M10S supports the following interface protocols:

Protocol	Type
UBX	Input/output, binary, u-blox proprietary
NMEA versions 2.1, 2.3, 4.0, 4.10 and 4.11 (default).	Input/output, ASCII

Table 7: Supported protocols

1.5 Firmware features

Feature	Description
Antenna supervisor ¹⁴	Antenna supervisor for active antenna control and short detection
CloudLocate GNSS	Extends the life of energy-constrained IoT applications. Small payload messages supported.
Assisted GNSS	AssistNow Online, AssistNow Offline and AssistNow Autonomous
Backup modes	Hardware backup mode and software standby mode
Power save modes ¹⁵	On/off, cyclic tracking
Super-S	Improved dynamic position accuracy with small antennas

¹³ BeiDou B1I cannot be enabled simultaneously with BeiDou B1C or GLONASS L1OF.

¹⁴ External components required, some pins need to be reconfigured.

¹⁵ The power save modes are not available if BeiDou B1C is enabled.

Feature	Description
Protection level	Real-time position accuracy estimate with 95% confidence level ¹⁶
Galileo return link messages	Galileo search and rescue (SAR) return link messages (RLM) via Galileo satellite signal
Data batching	Autonomous tracking up to 10 minutes at 1 Hz
Odometer	Measure traveled distance with support for different user profiles

Table 8: Firmware features

Feature	Description
Anti-jamming	RF interference and jamming detection and reporting
Anti-spoofing	Spoofing detection and reporting
Configuration lockdown	Receiver configuration can be locked by command
Message integrity	All messages can be cryptographically signed
Secure boot	Only signed firmware images executed

Table 9: Security features

¹⁶ Verified for automotive environment only.

2 System description

2.1 Block diagram

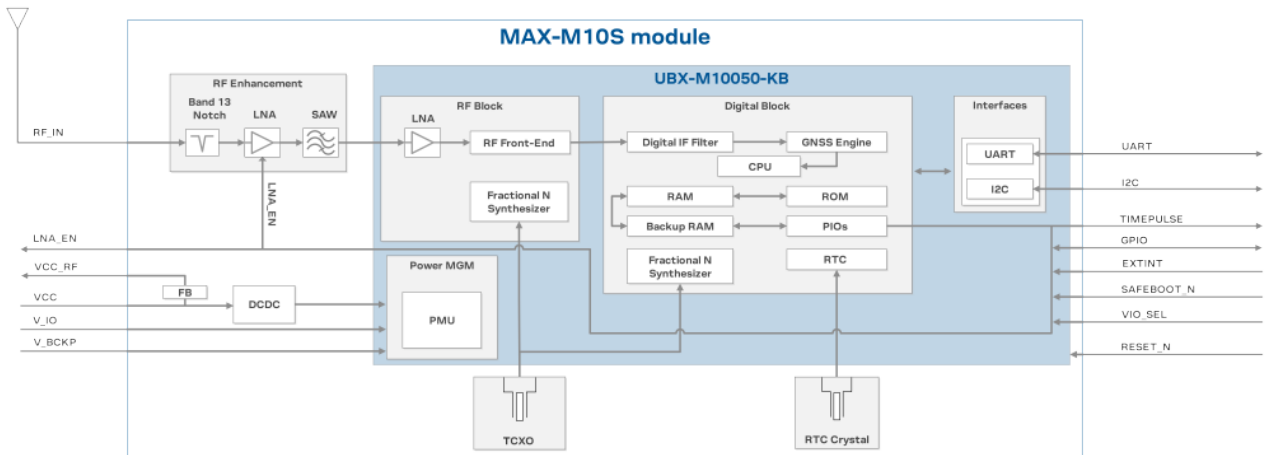

Figure 1: MAX-M10S block diagram

3 Pin definition

3.1 Pin assignment

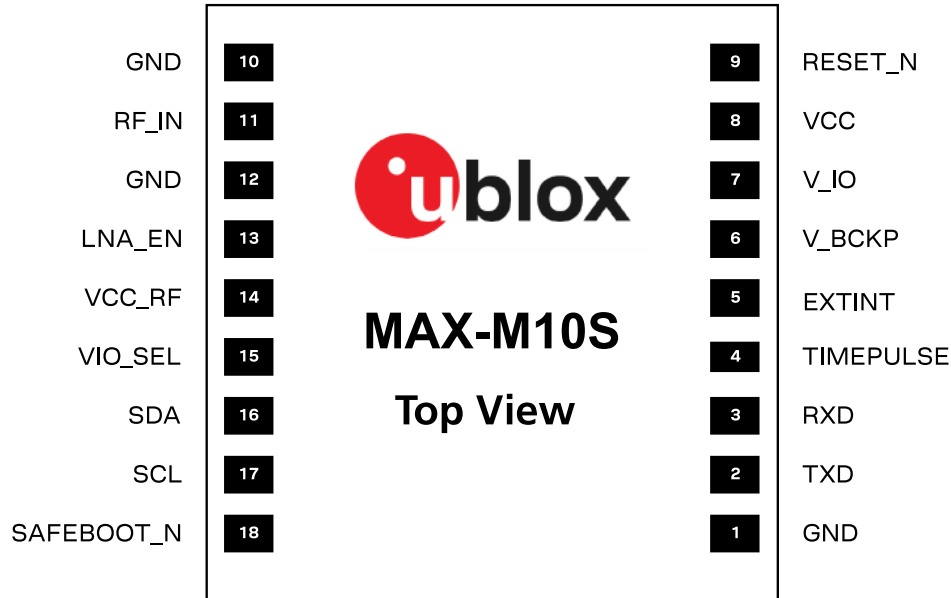

Figure 2: MAX-M10S pin assignment

Pin no.	Name	PIO no.	I/O	Description
1	GND	-	-	Connect to GND
2	TXD	1	O	UART TX
3	RXD	0	I	UART RX
4	TIMEPULSE	4	O	Time pulse signal (shared with SAFEBOOT_N pin) ¹⁷
5	EXTINT	5	I	External interrupt
6	V_BCKP	-	I	Backup voltage supply
7	V_IO	-	I	IO voltage supply
8	VCC	-	I	Main voltage supply
9	RESET_N	-	I	System reset (active low). Has to be low for at least 1 ms to trigger a reset.
10	GND	-	-	Connect to GND
11	RF_IN	-	I	GNSS signal input
12	GND	-	-	Connect to GND
13	LNA_EN	-	O	On/Off external LNA or active antenna
14	VCC_RF	-	O	Output voltage RF section
15	VIO_SEL	-	I	Voltage selector for V_IO supply. Connect to GND for 1.8 V supply, or leave open for 3.3 V supply.
16	SDA	2	I/O	I2C data
17	SCL	3	I	I2C clock
18	SAFEBOOT_N	-	I	Safeboot mode (leave open) ¹⁷

Table 10: MAX-M10S pin assignment

¹⁷ The receiver enters safeboot mode if this pin is low at start up. The SAFEBOOT_N pin is internally connected to TIMEPULSE pin through a 1 kΩ series resistor.

3.2 Pin state

Table 11 defines the state of the PIOs and RESET_N pins in different modes. The functions of the PIOs are as defined in the default configuration.

PIO no.	Pin no.	Default function	Continuous mode	Software standby mode	Safe boot mode
0	3	RXD	Input pull-up	Input pull-up	Input pull-up
1	2	TXD	Output	Input pull-up	Output
2	16	SDA	Input pull-up	Input pull-up	Input pull-up
3	17	SCL	Input pull-up	Input pull-up	Input pull-up
4	18	SAFEBOOT_N	Output	Input pull-down	High Z
	4	TIMEPULSE	Output	Input pull-down	High Z

Table 11: Pins state



In reset mode (RESET_N = low), all PIOs are configured as input pull-up.



In hardware backup mode (VCC = 0 V and V_IO = 0 V), PIOs must not be driven.

4 Electrical specifications

CAUTION Operating the device above one or more of the limiting values may cause permanent damage to the device. The values provided in this chapter are stress ratings. Extended exposure to the values outside the limits may effect the device reliability.

Where application information is given, it is advisory only and does not form part of the specification.

4.1 Absolute maximum ratings

Symbol	Parameter	Min	Max	Unit
VCC	Main supply voltage	-0.3	3.6	V
V _{IO}	IO supply voltage	-0.3	VCC + 0.3 (max 3.6)	V
	Voltage ramp on V _{IO} ¹⁸	25	35000	µs/V
V _{BCKP}	Backup supply voltage	-0.3	3.6	V
V _{PIO}	Input voltage on RESET_N and digital pins. VIO_SEL = GND.	-0.3	V _{IO} + 0.3 (max 1.98)	V
	Input voltage on RESET_N and digital pins. VIO_SEL = open.	-0.3	V _{IO} + 0.3 (max 3.6)	V
I _{PIO}	Max source / sink current, digital pins ¹⁹	-10	10	mA
ICC _{RF}	Max source current, VCC _{RF}		250	mA
P _{rfin}	RF input power on RF_IN ²⁰		0	dBm
T _{amb}	Ambient temperature	-40	+85	°C
T _s	Storage temperature	-40	+85	°C

Table 12: Absolute maximum ratings

V_{IO} supply voltage must not be higher than VCC + 0.3 V.

The product is not protected against overvoltage or reversed voltages. Voltage spikes exceeding the power supply voltage specification, given in the table above, must be limited to values within the specified boundaries by using appropriate protection diodes.

4.2 Operating conditions

Table 13 shows the general operating conditions. Table 14 shows the electrical parameters for digital I/O.

The V_{IO} voltage range is selected with the VIO_SEL pin.

For designs with 1.8 V supply at V_{IO} and V_{BCKP} supplied, switch off V_{IO} supply 100 ms before VCC when transitioning to hardware backup mode. Alternatively, put the receiver to software standby mode by sending UBX-RXM-PMREQ message before switching off V_{IO} and VCC. For designs with 3 V supplies, both supplies can be switched off simultaneously or ensure that V_{IO} is switched off before VCC.

¹⁸ Exceeding the voltage ramp speed may permanently damage the device.

¹⁹ The SAFEBOOT_N pin has an internal 1 kΩ series resistor.

²⁰ Test conditions: source impedance = 50 Ω, continuous wave.

Symbol	Parameter	Min	Typical	Max	Unit
VCC	Main supply voltage	1.76	1.8, 3.3	3.6	V
V _{IO}	IO supply voltage, V _{IO_SEL} = GND	1.76	1.8	VCC (max 1.98)	V
	IO supply voltage, V _{IO_SEL} = open	2.7	3.3	VCC (max 3.6)	V
V _{BCKP}	Supply voltage, backup domain	1.65		3.6	V
V _{IO_SWITCH}	V _{IO} voltage threshold to switch an internal supply for the backup domain from V _{IO} to V _{BCKP}		1.45		V
VCC _{RF}	VCC _{RF} output voltage		VCC - 0.1		V
ICC _{RF}	VCC _{RF} output current			50	mA
NF _{tot}	Receiver chain noise figure		1.5		dB
Ext_gain ²¹	External gain at RF_IN, low gain mode (default)			30	dB
	External gain at RF_IN, bypass mode	10	25	40	dB
T _{opr}	Operating temperature	-40		+85	°C

Table 13: General operating conditions

Symbol	Parameter	Min	Typical	Max	Unit
I _{leak}	Leakage current input pins ²²		25		nA
V _{in}	Input pin voltage range	0		V _{IO}	V
V _{il}	Low-level input voltage			0.63	V
V _{ih}	High-level input voltage	0.68 x V _{IO}			V
V _{ol}	Low-level output voltage, I _{out} = -2 mA ²³			0.4	V
V _{oh}	High-level output voltage, I _{out} = 2 mA ²³	V _{IO} - 0.4			V
R _{pu, IO}	Pull-up resistance, Digital IO ²⁴ . V _{IO_SEL} = GND	6	17	72	kΩ
R _{pu, IO}	Pull-up resistance, Digital IO ²⁴ . V _{IO_SEL} = open	8	18	40	kΩ
R _{pd, IO}	Pull-down resistance, Digital IO	21	80	180	kΩ
R _{pu, SAFEBOOT_N}	Pull-up resistance, SAFEBOOT_N ²⁵	6	17	72	kΩ
R _{pu, RESET_N}	Pull-up resistance, RESET_N	7	10	13	kΩ

Table 14: Digital IO

 Operation beyond the specified operating conditions can affect device reliability.

4.3 Indicative power requirements

Table 15 shows indicative current consumption for VCC and V_{IO} with a 3.0 V supply.

²¹ The internal LNA gain is configurable.

²² V_{in} = V_{IO}, at room temperature.

²³ TIMEPULSE (PIO4) has 4 mA current drive/sink capability.

²⁴ TXD, RXD, TIMEPULSE, EXTINT, SCL, SDA, and LNA_EN.

²⁵ The SAFEBOOT_N pin has an additional 1 kΩ series resistor.

Symbol (Parameter)	Conditions	GPS	GPS+GAL	GPS+GAL +GLO	GPS+GAL +BDS B1I (default)	GPS+GAL +BDS B1C	GPS+GAL +BDS B1C +GLO	Unit
I_{VCC} ^{26, 27} (Current at VCC)	Acquisition ²⁸	8	10	12	11.5	11	13	mA
	Tracking (Continuous mode)	7.5	8	9	9.5	8.5	10	mA
	Tracking (Power save mode) ²⁹	4.5	5	5	5	-	-	mA
$I_{V_{IO}}$ ²⁶ (Current at V _{IO})	Acquisition and Tracking (Continuous mode)	2.1	2.2	2.3	2.3	2.2	2.3	mA
	Tracking	2	2	2	2	-	-	mA
	Tracking (Power save mode) ²⁹	2	2	2	2	-	-	mA

Table 15: Typical currents for 3.0 V supply at VCC and V_{IO}

Table 16 shows indicative current consumption for VCC and V_{IO} with a 1.8 V supply.

Symbol (Parameter)	Conditions	GPS	GPS+GAL	GPS+GAL +GLO	GPS+GAL +BDS B1I (default)	GPS+GAL +BDS B1C	GPS+GAL +BDS B1C +GLO	Unit
I_{VCC} ^{26, 27} (Current at VCC)	Acquisition ²⁸	10.5	15.5	17.5	16.5	16	18.5	mA
	Tracking (Continuous mode)	9.5	11	12.5	13	11.5	14	mA
	Tracking (Power save mode) ²⁹	5.5	6.0	6.5	6.5	-	-	mA
$I_{V_{IO}}$ ²⁶ (Current at V _{IO})	Acquisition and Tracking (Continuous mode)	2.1	2.1	2.2	2.2	2.1	2.2	mA
	Tracking	2	2	2	2	-	-	mA
	Tracking (Power save mode) ²⁹	2	2	2	2	-	-	mA

Table 16: Typical currents for 1.8 V supply at VCC and V_{IO}

These values are provided for customer information only, as an example of typical current requirements. They are characterized on samples using a cold start command. Actual power requirements can vary depending on firmware version used, external circuitry, number of satellites tracked, signal strength, type and time of start, duration, internal LNA gain mode, and test conditions.



The inrush current at startup can go up to 100 mA. Ensure that the external power supply is able to deliver up to 100 mA.

Table 17 shows current consumptions for the backup modes.

Symbol	Parameter	Conditions	Typ.	Unit
$I_{V_{BCKP}}$ ³⁰	Total current in hardware backup mode	$V_{BCKP} = 3.3\text{ V}$, $V_{IO} = VCC = 0\text{ V}$	28	μA
$I_{V_{IO}}$	V_{IO} current in software standby mode	$V_{IO} = 1.8\text{ V}$	37	μA
		$V_{IO} = 3.3\text{ V}$	46	μA

²⁶ 1 Hz navigation update rate.

²⁷ Internal LNA set to low gain. Simulated signal using power levels of -130 dBm.

²⁸ Average current from start-up until the first fix.

²⁹ Cyclic tracking operation. BeiDou B1C is not supported in this mode.

³⁰ $I_{V_{BCKP}}$ current in normal operation ($V_{BCKP} = 3.3\text{ V}$, $V_{IO} = VCC = 3.3\text{ V}$) is $\sim 3\text{ }\mu\text{A}$.

Symbol	Parameter	Conditions	Typ.	Unit
I_{VCC}	VCC current in software standby mode	VCC = 3.3 V	120	nA

Table 17: Backup currents

All values in [Table 15](#), [Table 16](#), and [Table 17](#) are measured at 25 °C ambient temperature and with the internal LNA set to low gain. SBAS and QZSS are activated in all measurements.

5 Communication interfaces

The receiver supports communication over UART and I2C interfaces.

All the inputs have an internal pull-up resistor in normal operation and can be left open if not used. The voltage level at the PIO pins is related to the V_{IO} supply voltage.

5.1 UART

The UART interface supports configurable baud rates. Hardware flow control is not supported. UART specifications are described in [Table 18](#).

Symbol	Parameter	Min	Max	Unit
R _u	Baud rate	4800	921600	bit/s
Δ _{Tx}	Tx baud rate accuracy	-1%	+1%	-
Δ _{Rx}	Rx baud rate tolerance	-2.5%	+2.5%	-

Table 18: UART specifications

5.2 I2C

An I2C interface is available for communication with an external host CPU in I2C Fast-mode. Backwards compatibility with Standard-mode I2C bus operation is not supported. The interface can be operated only in slave mode with a maximum bit rate of 400 kbit/s³¹.

The interface can make use of clock stretching by holding the SCL line LOW to pause a transaction. In this case, the bit transfer rate is reduced. The maximum clock stretching time is 20 ms.

5.3 Default interface settings

Interface	Settings
UART	<ul style="list-style-type: none"> 9600 baud, 8 bits, no parity bit, 1 stop bit. Input messages: NMEA and UBX. Output messages: NMEA GGA, GLL, GSA, GSV³², RMC, VTG and TXT.
I2C	<ul style="list-style-type: none"> 7-bit I2C address (0x42). Input messages: NMEA and UBX. Output messages: NMEA GGA, GLL, GSA, GSV³², RMC, VTG and TXT.

Table 19: Default interface settings

³¹ External pull-up resistors may be needed to achieve 400 kbit/s communication speed, as the internal pull-up resistance can be very large.

³² In the default configuration, the NMEA-GSV messages are sent at 5-second intervals to avoid overflow in the TX buffer.

6 Mechanical specifications

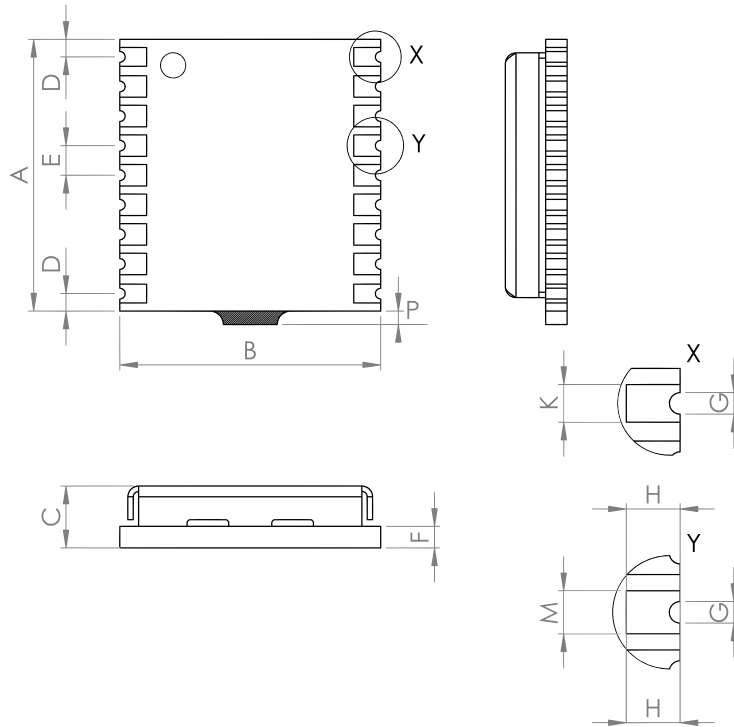

Figure 3: MAX-M10S mechanical drawing

Symbol	Min (mm)	Typical (mm)	Max (mm)
A	10.0	10.1	10.7
B	9.6	9.7	9.8
C	2.2	2.5	2.7
D	0.55	0.65	0.95
E	1.0	1.1	1.2
F	-	0.76	-
G	0.3	0.4	0.5
H	0.9	1.0	1.1
K	0.6	0.7	0.8
M	0.7	0.8	0.9
P	0.0	0.3	0.6
Weight		0.6 g	

Table 20: MAX-M10S mechanical dimensions



The mechanical picture of the de-paneling residual tab (P) is an approximate representation, shape and position may vary.

7 Approvals

The MAX-M10S is designed for the presumption of conformity with the essential requirements and other relevant provisions of Radio Equipment Directive (RED) 2014/53/EU.

The MAX-M10S complies with the Directive 2011/65/EU (EU RoHS 2) and its amendment Directive (EU) 2015/863 (EU RoHS 3).

The Declaration of Conformity (DoC) is available at [u-blox website](#) within Support > File Category > Conformity and Certification .

8 Product handling

8.1 Moisture sensitivity level

The moisture sensitivity level (MSL) relates to the packaging and handling precautions required. MAX-M10S LCC (professional grade) package is rated at MSL level 4. For MSL standard, see IPC/JEDEC J-STD-020 [5].

9 Labeling and ordering information

This section provides information about product labeling and ordering.

9.1 Product labeling

The labeling of MAX-M10S package provides product information and revision information. For more information contact u-blox sales.

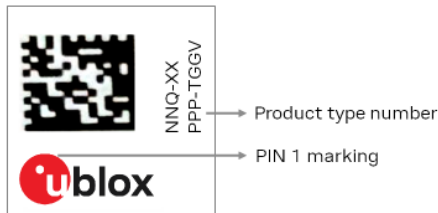

Figure 4: MAX-M10S label

The parts of the product code are explained in [Table 21](#)

Code	Meaning	Example
PPP	Product family	MAX
TGG	Platform	M10 = u-blox M10
V	Variant	S = Standard precision, ROM, TCXO, LNA, and SAW filter
NN	Option	00, 01, 02, ...
Q	Quality grade	A = Automotive, B = Professional
XX	Product detail	Describes hardware and firmware versions

Table 21: Part identification code

9.2 Explanation of product codes

Three product code formats are used. The product name is used in documentation such as this data sheet and identifies all u-blox products, independent of packaging and quality grade. The ordering code includes options and quality, while the type number includes the hardware and firmware versions.

[Table 22](#) details these three different formats for MAX-M10S module.

Format	Structure	Product code
Product name	PPP-TGGV	MAX-M10S
Ordering code	PPP-TGGV-NNQ	MAX-M10S-00B
Type number	PPP-TGGV-NNQ-XX	MAX-M10S-00B-01

Table 22: Product code formats

9.3 Ordering codes

Ordering code	Product	Remark
MAX-M10S-00B	u-blox M10 GNSS receiver module, professional grade	

Table 23: Product ordering codes



Product changes affecting form, fit or function are documented by u-blox. For a list of Product Change Notifications (PCNs) see our website at: <https://www.u-blox.com/en/product-resources>.

Related documents

- [1] MAX-M10S Integration manual, [UBX-20053088](#)
- [2] u-blox M10 SPG 5.10 Interface description, [UBX-21035062](#)
- [3] u-blox M10 SPG 5.10 Release notes, [UBX-22001426](#)
- [4] u-blox Package Information Guide, [UBX-14001652](#)
- [5] MSL standard IPC/JEDEC J-STD-020, www.jedec.org



For regular updates to u-blox documentation and to receive product change notifications please register on our homepage <https://www.u-blox.com>.

Revision history

Revision	Date	Name	Status / comments
R01	21-Dec-2020	imar, jesk, msul, rmak	Objective specification
R02	20-Apr-2021	rmak	Advance information. Updated Firmware features, Pin assignment, Absolute maximum ratings, Operating conditions, Indicative power requirements, and Product labeling. Minor revision.
R03	28-Jun-2022	imar, oola	New product type number for MAX-M10S-00B-01 with ROM SPG 5.10 firmware. Updated Document information, Pin definition, Performance figures and Indicative power requirements with new GNSS configurations. Updated Electrical specifications, Operating conditions, and Absolute maximum ratings. Added configuration lock and power save modes features, maximum I2C clock stretching time, MSL specification and Reliability tests and approvals.
R04	16-May-2023	oola	Updated maximum navigation update rate in section Performance, ICC_RF in section Absolute maximum ratings, VCC and V_IO supply timing requirements in Operating conditions, and section Mechanical specifications. Added 1 Hz navigation update rate footnote in section Indicative power requirements.

Contact

u-blox AG

Address: Zürcherstrasse 68
8800 Thalwil
Switzerland

For further support and contact information, visit us at www.u-blox.com/support.