

**Impact™  
Backplane  
Module Installation  
Press-In Tool**

**molex**

**Application Tooling  
Specification Sheet**

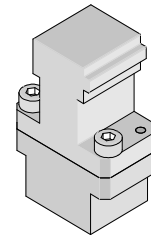

**Order No. 62201-8787**

## FEATURES

- Polarized tool prevents product damage
- Tool provides uniform distribution of press force across entire pin array
- May be used as a stand-alone tool or mounted in an optional holder with other Molex press-in tools

## SCOPE

**Products:** Impact™ Backplane Signal Module Assembly, 170335 Series, (4-Pair by 8 Column 85 Ohm Assemblies). See Product List below for specific part numbers.

## Product List

The following is a partial list of the product order numbers and their specifications this tool is designed to run. Updates to this list are available on [www.molex.com](http://www.molex.com).

| 4 Pair 170335 Series Numbers |             |                       |             |             |             |             |             |
|------------------------------|-------------|-----------------------|-------------|-------------|-------------|-------------|-------------|
| Guide Style                  | Columns     | Assembly Order Number |             |             |             |             |             |
| Unguided                     | 8           | 170335-1803           | 170335-1804 | 170335-1805 | 170335-1806 | 170335-1807 | 170335-1808 |
|                              |             | 170335-1813           | 170335-1814 | 170335-1815 | 170335-1816 | 170335-1817 | 170335-1818 |
|                              |             | 170335-1823           | 170335-1824 | 170335-1825 | 170335-1826 | 170335-1827 | 170335-1828 |
|                              |             | 170335-1833           | 170335-1834 | 170335-1835 | 170335-1836 | 170335-1837 | 170335-1838 |
| Left                         | 8           | 170335-2803           | 170335-2804 | 170335-2805 | 170335-2806 | 170335-2807 | 170335-2808 |
|                              |             | 170335-2813           | 170335-2814 | 170335-2815 | 170335-2816 | 170335-2817 | 170335-2818 |
|                              |             | 170335-2823           | 170335-2824 | 170335-2825 | 170335-2826 | 170335-2827 | 170335-2828 |
|                              |             | 170335-2833           | 170335-2834 | 170335-2835 | 170335-2836 | 170335-2837 | 170335-2838 |
|                              |             | 170335-2843           | 170335-2844 | 170335-2845 | 170335-2846 | 170335-2847 | 170335-2848 |
|                              |             | 170335-2853           | 170335-2854 | 170335-2855 | 170335-2856 | 170335-2857 | 170335-2858 |
|                              |             | 170335-2863           | 170335-2864 | 170335-2865 | 170335-2866 | 170335-2867 | 170335-2868 |
|                              |             | 170335-2873           | 170335-2874 | 170335-2875 | 170335-2876 | 170335-2877 | 170335-2878 |
|                              |             | 170335-2883           | 170335-2884 | 170335-2885 | 170335-2886 | 170335-2887 | 170335-2888 |
|                              |             | 170335-6803           | 170335-6804 | 170335-6805 | 170335-6806 | 170335-6807 | 170335-6808 |
|                              |             | 170335-6813           | 170335-6814 | 170335-6815 | 170335-6816 | 170335-6817 | 170335-6818 |
|                              |             | 170335-6823           | 170335-6824 | 170335-6825 | 170335-6826 | 170335-6827 | 170335-6828 |
|                              |             | 170335-6833           | 170335-6834 | 170335-6835 | 170335-6836 | 170335-6837 | 170335-6838 |
|                              |             | 170335-6843           | 170335-6844 | 170335-6845 | 170335-6846 | 170335-6847 | 170335-6848 |
|                              |             | 170335-6853           | 170335-6854 | 170335-6855 | 170335-6856 | 170335-6857 | 170335-6858 |
|                              |             | 170335-6863           | 170335-6864 | 170335-6865 | 170335-6866 | 170335-6867 | 170335-6868 |
| 170335-6873                  | 170335-6874 | 170335-6875           | 170335-6876 | 170335-6877 | 170335-6878 |             |             |
| 170335-6883                  | 170335-6884 | 170335-6885           | 170335-6886 | 170335-6887 | 170335-6888 |             |             |
| Right                        | 8           | 170335-4803           | 170335-4804 | 170335-4805 | 170335-4806 | 170335-4807 | 170335-4808 |
|                              |             | 170335-4813           | 170335-4814 | 170335-4815 | 170335-4816 | 170335-4817 | 170335-4818 |
|                              |             | 170335-4823           | 170335-4824 | 170335-4825 | 170335-4826 | 170335-4827 | 170335-4828 |
|                              |             | 170335-4833           | 170335-4834 | 170335-4835 | 170335-4836 | 170335-4837 | 170335-4838 |

|             |         | 4 Pair 170335 Series Numbers |             |             |             |             |             |
|-------------|---------|------------------------------|-------------|-------------|-------------|-------------|-------------|
| Guide Style | Columns | Assembly Order Number        |             |             |             |             |             |
| Right       | 8       | 170335-4843                  | 170335-4844 | 170335-4845 | 170335-4846 | 170335-4847 | 170335-4848 |
|             |         | 170335-4853                  | 170335-4854 | 170335-4855 | 170335-4856 | 170335-4857 | 170335-4858 |
|             |         | 170335-4863                  | 170335-4864 | 170335-4865 | 170335-4866 | 170335-4867 | 170335-4868 |
|             |         | 170335-4873                  | 170335-4874 | 170335-4875 | 170335-4876 | 170335-4877 | 170335-4878 |
|             |         | 170335-4883                  | 170335-4884 | 170335-4885 | 170335-4886 | 170335-4887 | 170335-4888 |
|             |         | 170335-8803                  | 170335-8804 | 170335-8805 | 170335-8806 | 170335-8807 | 170335-8808 |
|             |         | 170335-8813                  | 170335-8814 | 170335-8815 | 170335-8816 | 170335-8817 | 170335-8818 |
|             |         | 170335-8823                  | 170335-8824 | 170335-8825 | 170335-8826 | 170335-8827 | 170335-8828 |
|             |         | 170335-8833                  | 170335-8834 | 170335-8835 | 170335-8836 | 170335-8837 | 170335-8838 |
|             |         | 170335-8843                  | 170335-8844 | 170335-8845 | 170335-8846 | 170335-8847 | 170335-8848 |
|             |         | 170335-8853                  | 170335-8854 | 170335-8855 | 170335-8856 | 170335-8857 | 170335-8858 |
|             |         | 170335-8863                  | 170335-8864 | 170335-8865 | 170335-8866 | 170335-8867 | 170335-8868 |
|             |         | 170335-8873                  | 170335-8874 | 170335-8875 | 170335-8876 | 170335-8877 | 170335-8878 |
|             |         | 170335-8883                  | 170335-8884 | 170335-8885 | 170335-8886 | 170335-8887 | 170335-8888 |

### Tool Setup

Depending on the number of connectors to be installed and/or the press used, this tool can be used alone or with a group of press-in tools, mounted in a 62201-95XX rail (ordered separately). See Figure 1.

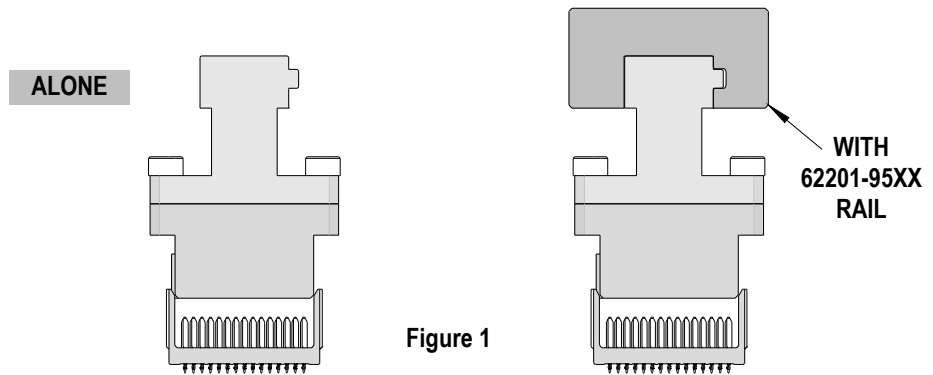

Figure 1

### Tool Installation

The 62201-95XX rail is available in a variety of lengths to accommodate multiple press-in tools.

| Rail Part Number | Rail Overall Length |
|------------------|---------------------|
| 62201-9501       | 24mm (0.94 in)      |
| 62201-9502       | 72mm (2.83 in)      |
| 62201-9503       | 156mm (6.14 in)     |
| 62201-9504       | 216mm (8.50 in)     |
| 62201-9509       | 254mm (10.0 in)     |
| 62201-9511       | 305mm (12.0 in)     |

Reference: This Press-In Tool is 15.1mm (0.59 in.) long.

### Printed Circuit Board (PCB) Support

The Impact™ connectors require up to 3.6kg (8 lb) of force per pin to press into the PCB. To prevent excessive PCB flexure and/or damage to the PCB, a support plate is strongly recommended directly beneath the connector hole pattern.

Due to the custom nature of every application, Molex does not offer any PCB support plate. The customer must furnish their own support plate.

When creating the PCB support plate, remember to allow clearance for the connector pins as they pass through the PCB thickness.

## Press Equipment Recommendations

Many types of presses can be used to install Impact™ connectors, but to assure consistent connector installation Molex recommends the following press criteria:

1. The capability to detect force variations as low as 4.5kg (10 lb) during the press-in cycle; excessive force measurements should stop the press-in cycle.
2. The rate of pressing can be regulated as low as 0.13mm (0.005 in) per second.
3. Press stroke control to within 0.25mm (0.010 in).
4. Total press stroke must be at least 19mm (0.75 in).
5. For statistical purposes, automatic collection of force and distance data.

## Tool Operation

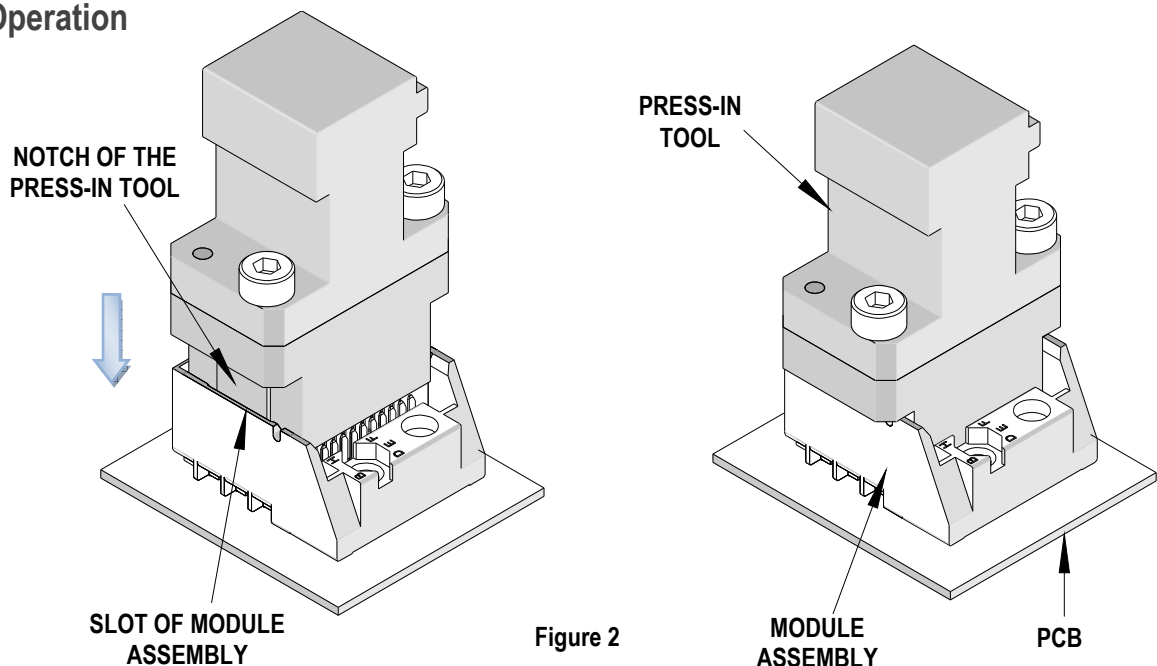

Figure 2

1. Insert by hand the backplane signal module assembly (s) carefully into the PCB hole pattern. Make sure the connector(s) are oriented properly by confirming the location of the #1 circuit notch with respect to the PCB layout.
2. Insert the Press-In Tool making sure that the notch in this tool is inserted into the slot on top of the connector housing of the backplane signal module assembly. See Figure 2.
3. Using the application tool and an appropriate press, seat the header assembly until there is less than 0.10mm (.004 in) clearance between the bottom of the plastic housing and the surface of the PCB. See Figure 3.

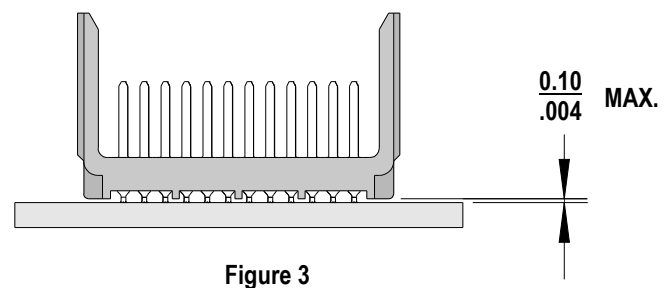

Figure 3

There should be no broken stand-offs along the perimeter of the part (an indication of over-pressing).

**CAUTION:** To prevent injury, never operate any press without the guards in place. Refer to the press manufacturer's instruction manual.

**CAUTION:** Molex application tooling specifications are valid only when used with Molex connectors and tooling.

### Contact Information

For more information on Molex application tooling please contact Molex at 1-800-786-6539.

Visit our Web site at <http://www.molex.com>