

Gewindegrund Ende  
thread base end

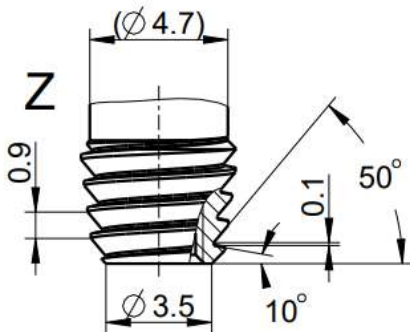

Gewindegrund Anfang / thread base start,  
gestreht mit / threaded with 7.5°

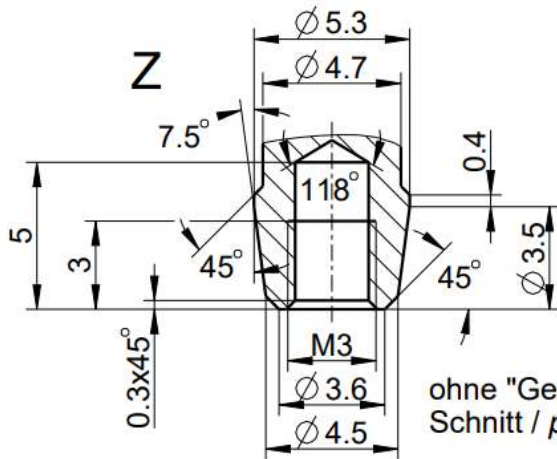

ohne "Gewinde" / without "thread"  
Schnitt / profile cut

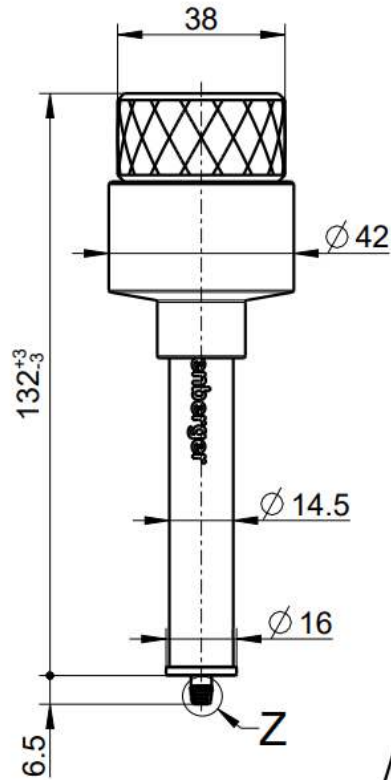

All dimensions are in mm; tolerances according to ISO 2768 m-H

**Application**

Series

for EBC press-in connector

While the information has been carefully compiled to the best of our knowledge, nothing is intended as representation or warranty on our part and no statement herein shall be construed as recommendation to infringe existing patents. In the effort to improve our products, we reserve the right to make changes judged to be necessary.

For the installation of the electrotechnical equipment, particular electrotechnical expertise is required.



Draft	Date	Approved	Date	Rev.	Engineering change number	Name	Date
C. Schmidinger	30.04.19	B. Aicher	31.01.23	b00	23-0198	S. Schier	30.01.23

Rosenberger Hochfrequenztechnik GmbH & Co. KG  
P.O.Box 1260 D-84526 Tittmoning Germany  
[www.rosenberger.com](http://www.rosenberger.com)

Tel. : +49 8684 18-0  
Email : [info@rosenberger.com](mailto:info@rosenberger.com)

Page

1 / 1