

THIS DRAWING IS UNPUBLISHED. RELEASED FOR PUBLICATION, 19 .  
 © COPYRIGHT 19 BY AMP INCORPORATED. ALL INTERNATIONAL RIGHTS RESERVED.

LOC		DIST		P		F		ZONE		LTR		REVISIONS		DATE	APPD
CH	11											B	ECN 95030204	02/MAR/95	P.G.

1. RETROFIT CONTACT FOR METRIMATE AND AMPLIMITE POWER CONTACT.
2. WIRE BARREL WILL ACCEPT #10 AWG WIRE.
3. MATES WITH PN 193643-1.

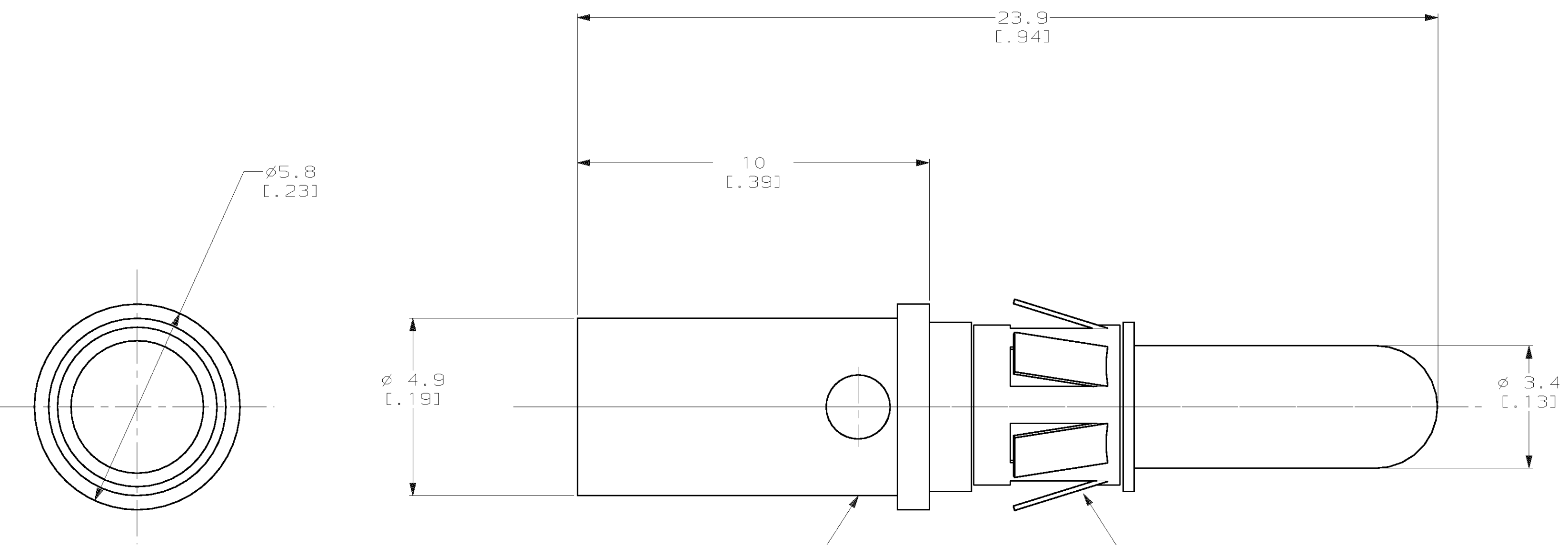

PIN BODY  
 MATERIAL: COPPER ALLOY  
 FINISH: 0.76µM [.000030] MIN GOLD OVER  
 1.27µM [.000050] MIN NICKEL

RETENTION CLIP  
 MATERIAL: STAINLESS STEEL

193642-1  
 PART NO

DO NOT SCALE PRINT. UNLESS SPECIFIED DIMENSIONS IN mm [INCHES] TOLERANCES ON : 2 PLC DEC ±0.5 [.02] 3 PLC DEC ±0.25 [.010] ANGLES ± -	DR D. WILSON 08-12-92	AMP Incorporated Harrisburg, PA 17105-3608
	CHK R. JAYNE 08-17-92	
MATERIAL -	APPD A. GRIFFIN 08-17-92	NAME
	APPD P. GLASER 08-17-92	PIN ASSY, POWER, #10 AWG
FINISH -	PRODUCT SPEC -	SIZE
	APPLICATION SPEC -	CAGE CODE
THIS DRAWING IS A CONTROLLED DOCUMENT FOR AMP INCORPORATED. IT IS SUBJECT TO CHANGE AND THE CONTROLLING ENGINEERING ORGANIZATION SHOULD BE CONTACTED FOR THE LATEST REVISION.	WEIGHT -	DRAWING NO
		SCALE 10:1
		SHEET 1 OF 1