

REVISIONS					
REV	ECO	DESCRIPTION	DATE	BY	APPR
A1	--	RELEASE NEW DRAWING	28MAR22	VITO	TOMMY

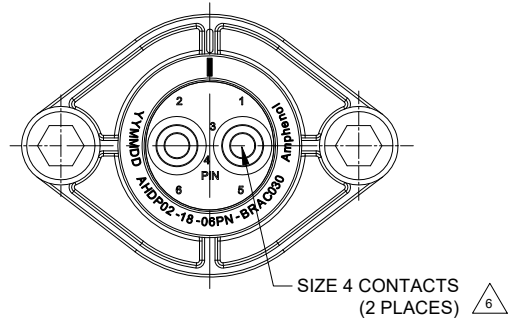
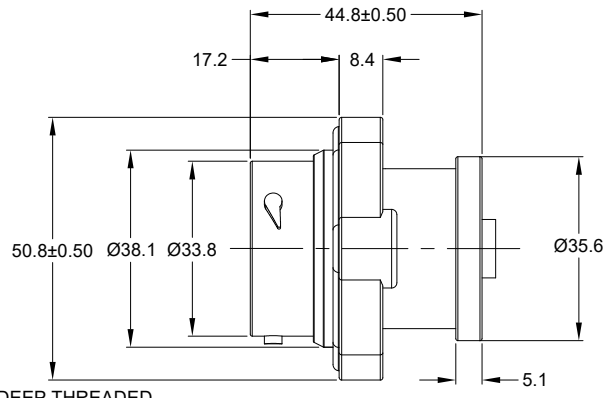
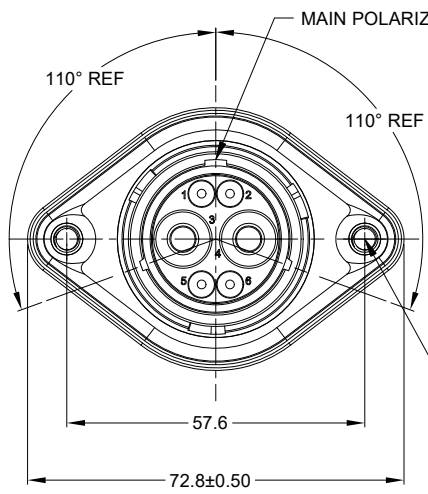

M5X0.8-6H 8mm(2X) DEEP THREADED INSERT
 RECOMMENDED TORQUE VALUES: 1.9-2.2 N.m

NOTES: UNLESS OTHERWISE SPECIFIED

- MATERIAL:
 HOUSING: THERMOPLASTIC; BLACK
 SEAL: SILICONE RUBBER
 THREADED INSERT: STAINLESS STEEL
- MODIFICATIONS: BACKSHELL RING ADAPTER (BRA);
 STANDARD DIA. WIRE SEAL.
 SEALED PANEL MOUNT;
- SPECIFICATIONS:
 3.1 OPERATING TEMPERATURE: -55°C TO +125°C.
 3.2 DIELECTRIC WITHSTANDING VOLTAGE: LESS THAN 2 MILLIAMPS CURRENT LEAKAGE @ 1500 VOLTS AC.
 3.3 INSULATION RESISTANCE: 1000 MEGOHM MIN @ 25°C.
 3.4 MOISTURE RESISTANCE:
 IP68 (IM OF WATER FOR A PERIOD OF 24 HOURS, MATED CONDITION);
 IP69K (MATED CONDITION)
 3.5 MATING CYCLE DURABILITY: 100 CYCLES
 3.6 RoHS COMPLIANT
- MATING PART: AHDP06-18-06S* (* = SEAL TYPE) (C030 OPTION)
- ALL DIMENSIONS ARE FOR REFERENCE USE ONLY.

6 CONTACT SIZE AND WIRE RANGE:

CONTACT SIZE	MIN. INSUL O.D.	MAX. INSUL O.D.	TYPICAL WIRE RANGE	CURRENT RATING
4	6.63 mm (.261in)	7.41mm (.292 in)	6 AWG (16-13mm ²)	100 AMPS

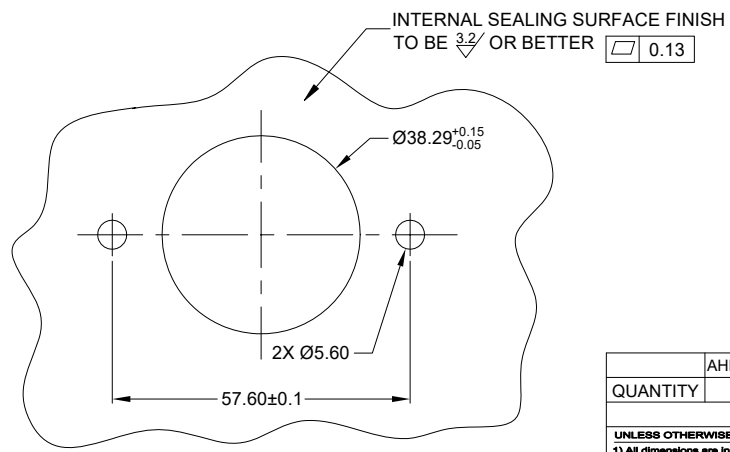

RECOMMENDED PANEL MOUNTING HOLE
 RECOMMENDED PANEL THICKNESS: 1.6 TO 4.7MM

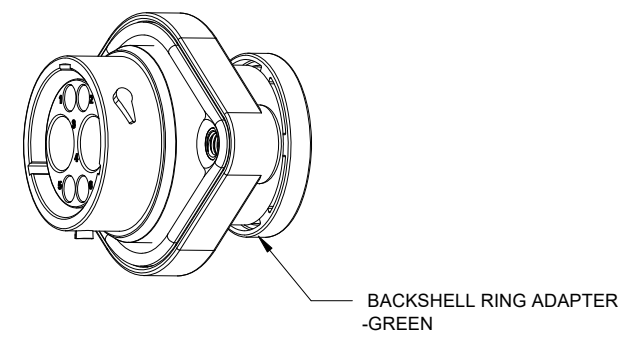

AHDPO2-18-06PN-BRAC030		DESCRIPTION		ITEM
QUANTITY	PART NUMBER	DESCRIPTION		ITEM
MATERIALS LIST				
UNLESS OTHERWISE SPECIFIED 1) All dimensions are in metric (mm). 2) Tolerances are as follows: 1 PL DEC ±0.30 Fractions ±1/64 2 PL DEC ±0.15 Angles ±1° 3 PL DEC ±0.08 3) Note reference =		SIGNATURES DATE DRAWN: VITOLI 28MAR22 CHECKED: SULLENZHANG 28MAR22 ENGINEER: APPROVAL: TOMMY XIE 30MAR22 CUSTOMER:		
MATERIAL SPECIFICATIONS: WEIGHT: 55.8g		 Sine Systems - www.amphenol-sine.com 44724 Morley Drive Clinton Township, MI 48036 2 POS, RECEPTACLE, PIN, PANELMATE AHDP SIZE 18, NORMAL SEAL, BRA, C030		
PROCESS SPECIFICATIONS: NEXT ASSY:		THIS DRAWING IS SUPPLIED FOR INFORMATION ONLY. DESIGN FEATURES, SPECIFICATIONS AND PERFORMANCE DATA SHOWN HEREON ARE THE PROPERTY OF THE AMPHENOL CORPORATION. NO RIGHTS OF REPRODUCTION ARE IMPLIED. ALL DIMENSIONS ARE SUBJECT TO NORMAL MANUFACTURING VARIATIONS.		
		SIZE B C-	TYPE AHDP02-18-06PN-BRAC030	REVISION A1
		SCALE: NONE	DURAMATE	SHEET 1 OF 1

TITLE: 2POS, RECEPT, PIN, PANELMATE AHDP SIZE 18, NORMAL SEAL, BRA, C030
 DWG NO.: AHDP02-18-06PN-BRAC030
 REV: A1
 SH: 1
 OF: 1