

Tous droits strictement reserves. Reproduction ou communication a des tiers interdite sous quelque forme que ce soit sans autorisation écrite du propriétaire. Propriete de c FCI. Droits de reproduction FCI.

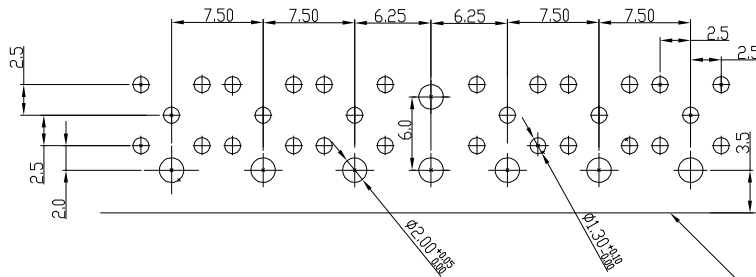

All rights strictly reserved. Reproduction or issue to third parties in any form whatever is not permitted without written authority from the proprietor. Property of FCI. Copyright FCI.

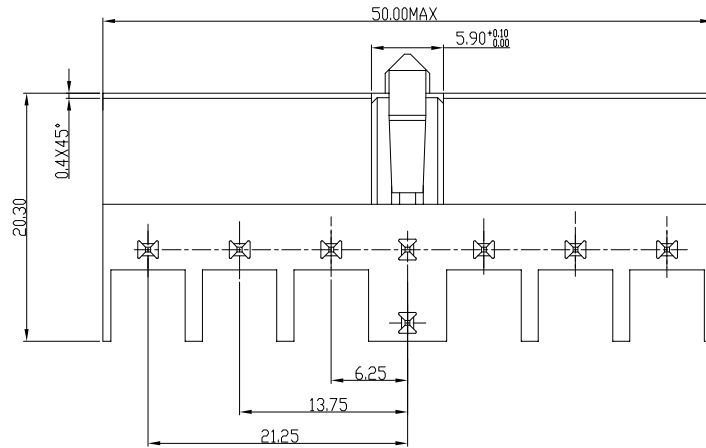
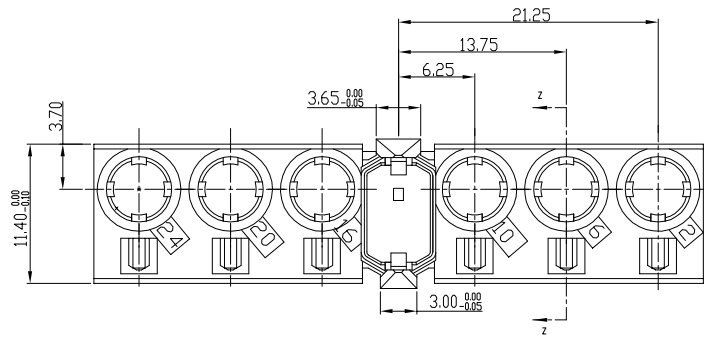

LAY-OUT
P.C.B.- HOLE

NOTES

1. THIS PRODUCT IS CSA APPROVED.
2. THIS PRODUCT IS UL RECOGNIZED.
3. MATERIAL: PLOYESTER 30% GLASS FILLED REINFORCED.
4. THIS PRODUCT (LF) MEETS EUROPEAN UNION DIRECTIVES AND OTHER COUNTRY REGULATIONS AS DESCRIBED IN GS-22-008.
5. THE HOUSING WILL WITHSTAND EXPOSURE TO 260°C PEAK TEMPERATURE FOR 30 SECONDS IN A VAVE SOLDER APPLICATION WITH A 1.6MM MINIMUM THICK CIRCUIT BOARD

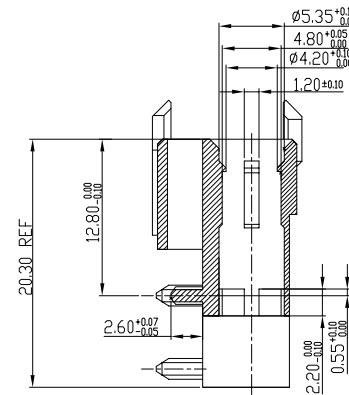
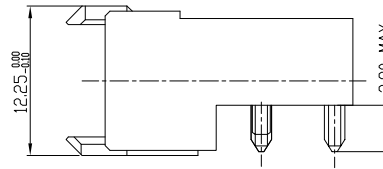

Material PLOYESTER 30% GLASS FILLED		Spec ref	
Mat code		tolerance 1DEC+0.2 1DEC 2DEC + 0.10 2DEC ANGLES+1*DEKEN	projection MM
Heattreat			
Plating/Finish		size A4	Scale 1.500
Dr	W.Panis 07-04-92		
Eng		Product family MILLIPICS	
Chr		Model Name ECN	
Appr		Model Revision REL Level	
FCJ		title MILLIPACS 2/FEMALE BODY/TYPE L	
Pro/E file	catalog no HM2R04P1LF	dwg no BSC201418004	Rev. C
		CUMSTOMER	sheet 1 of 1