

General Description

The ICS840022I-02 is a Gigabit Ethernet Clock Generator. The ICS840022I-02 uses a 25MHz crystal to synthesize 125MHz or 62.5MHz. The ICS840022I-02 has excellent phase jitter performance, over the 12kHz – 20MHz integration range. The ICS840022I-02 is packaged in a small 16-pin VFQFN, making it ideal for use in systems with limited board space.

Features

- One LVCMOS/LVTTL outputs, 20Ω output impedance
- Crystal oscillator interface designed for 25MHz, 18pF parallel resonant crystal
- Output frequencies: 125MHz or 62.5MHz
- RMS phase jitter at 125MHz using a 25MHz crystal (12kHz - 20MHz): 0.57ps (typical)
- Supply modes:
Core/Output
3.3V/3.3V
3.3V/2.5V
2.5V/2.5V
- -40°C to 85°C ambient operating temperature
- Available in lead-free (RoHS 6) package

Function Table

Inputs	
FREQ_SEL	Output Frequency Range (with a 25MHz crystal)
0	125MHz
1	62.5MHz

Block Diagram

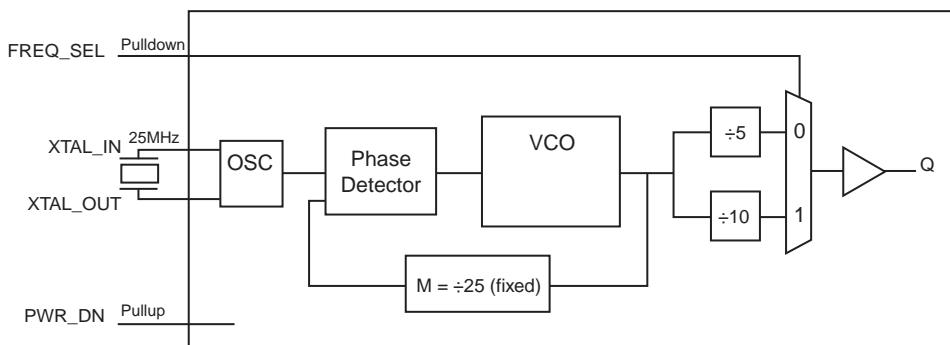

Pin Assignment

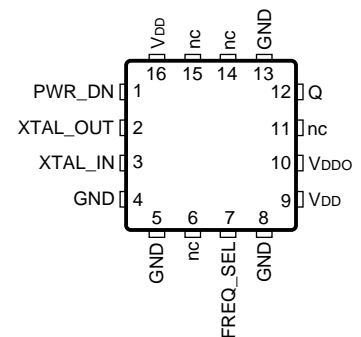

ICS840022I-02
16 Lead VFQFN
Top View

Table 1. Pin Descriptions

Number	Name	Type		Description
1	PWR_DN	Input	Pullup	Output state control pin. See Table 3. LVCMOS/LVTTL interface levels.
2, 3	XTAL_OUT, XTAL_IN	Input		Crystal oscillator interface. XTAL_IN is the input. XTAL_OUT is the output.
4, 5, 8, 13	GND	Power		Power supply ground.
6, 11, 14, 15	nc	Unused		No connect.
7	FREQ_SEL	Input	Pulldown	Frequency select pin. LVCMOS/LVTTL interface levels.
9, 16	V _{DD}	Power		Power supply pins.
10	V _{DDO}	Power		Output supply pin.
12	Q	Output		Single-ended clock output. 20Ω typical output impedance. LVCMOS/LVTTL interface levels.

NOTE: Pullup and Pulldown refer to internal input resistors. See Table 2, Pin Characteristics, for typical values.

Table 2. Pin Characteristics

Symbol	Parameter	Test Conditions	Minimum	Typical	Maximum	Units
C _{IN}	Input Capacitance			4		pF
C _{PD}	Power Dissipation Capacitance	V _{DD} , V _{DD} = 3.465V or 2.625V		10		pF
R _{PULLUP}	Input Pullup Resistor			51		kΩ
R _{PULLDOWN}	Input Pulldown Resistor			51		kΩ
R _{OUT}	Output Impedance			20		Ω

Function Table

Table 3. PWR_DN Function Table

PWR_DN Input	Description
0	Output in High-Impedance
1	Output in normal operation

Absolute Maximum Ratings

NOTE: Stresses beyond those listed under *Absolute Maximum Ratings* may cause permanent damage to the device. These ratings are stress specifications only. Functional operation of product at these conditions or any conditions beyond those listed in the *DC Characteristics* or *AC Characteristics* is not implied. Exposure to absolute maximum rating conditions for extended periods may affect product reliability.

Item	Rating
Supply Voltage, V_{DD}	4.6V
Inputs, V_I	-0.5V to $V_{DD} + 0.5V$
Outputs, V_O	-0.5V to $V_{DD} + 0.5V$
Package Thermal Impedance, θ_{JA}	74.9°C/W (0 mps)
Storage Temperature, T_{STG}	-65°C to 150°C

DC Electrical Characteristics

Table 4A. Power Supply DC Characteristics, $V_{DD} = V_{DDO} = 3.3V \pm 5\%$, $T_A = -40^\circ\text{C}$ to 85°C

Symbol	Parameter	Test Conditions	Minimum	Typical	Maximum	Units
V_{DD}	Power Supply Voltage		3.135	3.3	3.465	V
V_{DDO}	Output Supply Voltage		3.135	3.3	3.465	V
I_{DD}	Power Supply Current	PWR_DN = 1			77	mA
		PWR_DN = 0			<1	mA
I_{DDO}	Output Supply Current				12	mA

Table 4B. Power Supply DC Characteristics, $V_{DD} = V_{DDO} = 2.5V \pm 5\%$, $T_A = -40^\circ\text{C}$ to 85°C

Symbol	Parameter	Test Conditions	Minimum	Typical	Maximum	Units
V_{DD}	Power Supply Voltage		2.375	2.5	2.625	V
V_{DDO}	Output Supply Voltage		2.375	2.5	2.625	V
I_{DD}	Power Supply Current	PWR_DN = 1			68	mA
		PWR_DN = 0			<1	mA
I_{DDO}	Output Supply Current				10	mA

Table 4C. Power Supply DC Characteristics, $V_{DD} = 3.3V \pm 5\%$, $V_{DDO} = 2.5V \pm 5\%$, $T_A = -40^\circ\text{C}$ to 85°C

Symbol	Parameter	Test Conditions	Minimum	Typical	Maximum	Units
V_{DD}	Power Supply Voltage		3.135	3.3	3.465	V
V_{DDO}	Output Supply Voltage		2.375	2.5	2.625	V
I_{DD}	Power Supply Current	PWR_DN = 1			77	mA
		PWR_DN = 0			<1	mA
I_{DDO}	Output Supply Current				10	mA

Table 4D. LVCMOS/LVTTL DC Characteristics, $T_A = -40^{\circ}\text{C}$ to 85°C

Symbol	Parameter	Test Conditions	Minimum	Typical	Maximum	Units
V_{IH}	Input High Voltage	$V_{DD} = 3.465\text{V}$	2		$V_{DD} + 0.3$	V
		$V_{DD} = 2.625\text{V}$	1.7		$V_{DD} + 0.3$	V
V_{IL}	Input Low Voltage	$V_{DD} = 3.465\text{V}$	-0.3		0.8	V
		$V_{DD} = 2.625\text{V}$	-0.3		0.7	V
I_{IH}	Input High Current	FREQ_SEL $V_{DD} = V_{IN} = 3.465\text{V}$ or 2.625V			150	μA
		PWR_DN $V_{DD} = V_{IN} = 3.465\text{V}$ or 2.625V			5	μA
I_{IL}	Input Low Current	FREQ_SEL $V_{DD} = 3.465\text{V}$ or 2.625V , $V_{IN} = 0\text{V}$	-5			μA
		PWR_DN $V_{DD} = 3.465\text{V}$ or 2.625V , $V_{IN} = 0\text{V}$	-150			μA
V_{OH}	Output High Voltage; NOTE 1	$V_{DDO} = 3.465\text{V}$	2.6			V
		$V_{DDO} = 2.625\text{V}$	1.8			V
V_{OL}	Output Low Voltage; NOTE 1	$V_{DDO} = 3.465\text{V}$ or 2.625V			0.5	V

NOTE 1: Outputs terminated with 50Ω to $V_{DDO}/2$. See Parameter Measurement Information, Output Load Test Circuit diagrams.

Table 5. Crystal Characteristics

Parameter	Test Conditions	Minimum	Typical	Maximum	Units
Mode of Oscillation		Fundamental			
Frequency			25		MHz
Equivalent Series Resistance (ESR)				50	Ω
Shunt Capacitance				7	pF

AC Electrical Characteristics

Table 6A. AC Characteristics, $V_{DD} = V_{DDO} = 3.3V \pm 5\%$, $T_A = -40^\circ\text{C}$ to 85°

Symbol	Parameter	Test Conditions	Minimum	Typical	Maximum	Units
f_{OUT}	Output Frequency	FREQ_SEL = 0		125		MHz
		FREQ_SEL = 1		62.5		MHz
$\text{jit}(\emptyset)$	RMS Phase Jitter, Random; NOTE 1	125MHz, Integration Range: 12kHz – 20MHz		0.57		ps
		62.5MHz, Integration Range: 12kHz – 10MHz		0.58		ps
t_R / t_F	Output Rise/Fall Time	20% to 80%	200		700	ps
odc	Output Duty Cycle		47		53	%

NOTE: Electrical parameters are guaranteed over the specified ambient operating temperature range, which is established when the device is mounted in a test socket with maintained transverse airflow greater than 500 lfpm. The device will meet specifications after thermal equilibrium has been reached under these conditions.

NOTE 1: Refer to Phase Noise Plot.

Table 6B. AC Characteristics, $V_{DD} = V_{DDO} = 2.5V \pm 5\%$, $T_A = -40^\circ\text{C}$ to 85°

Symbol	Parameter	Test Conditions	Minimum	Typical	Maximum	Units
f_{OUT}	Output Frequency	FREQ_SEL = 0		125		MHz
		FREQ_SEL = 1		62.5		MHz
$\text{jit}(\emptyset)$	RMS Phase Jitter, Random; NOTE 1	125MHz, Integration Range: 12kHz – 20MHz		0.62		ps
		62.5MHz, Integration Range: 12kHz – 10MHz		0.58		ps
t_R / t_F	Output Rise/Fall Time	20% to 80%	200		700	ps
odc	Output Duty Cycle		47		53	%

NOTE: Electrical parameters are guaranteed over the specified ambient operating temperature range, which is established when the device is mounted in a test socket with maintained transverse airflow greater than 500 lfpm. The device will meet specifications after thermal equilibrium has been reached under these conditions.

NOTE 1: Refer to Phase Noise Plot.

Table 6C. AC Characteristics, $V_{DD} = 3.3V \pm 5\%$, $V_{DDO} = 2.5V \pm 5\%$, $T_A = -40^\circ\text{C}$ to 85°

Symbol	Parameter	Test Conditions	Minimum	Typical	Maximum	Units
f_{OUT}	Output Frequency	FREQ_SEL = 0		125		MHz
		FREQ_SEL = 1		62.5		MHz
$\text{jit}(\emptyset)$	RMS Phase Jitter, Random	125MHz, Integration Range: 12kHz – 20MHz		0.62		ps
		62.5MHz, Integration Range: 12kHz – 10MHz		0.58		ps
t_R / t_F	Output Rise/Fall Time	20% to 80%	200		750	ps
odc	Output Duty Cycle		47		53	%

NOTE: Electrical parameters are guaranteed over the specified ambient operating temperature range, which is established when the device is mounted in a test socket with maintained transverse airflow greater than 500 lfpm. The device will meet specifications after thermal equilibrium has been reached under these conditions.

Typical Phase Noise at 62.5MHz (3.3V)

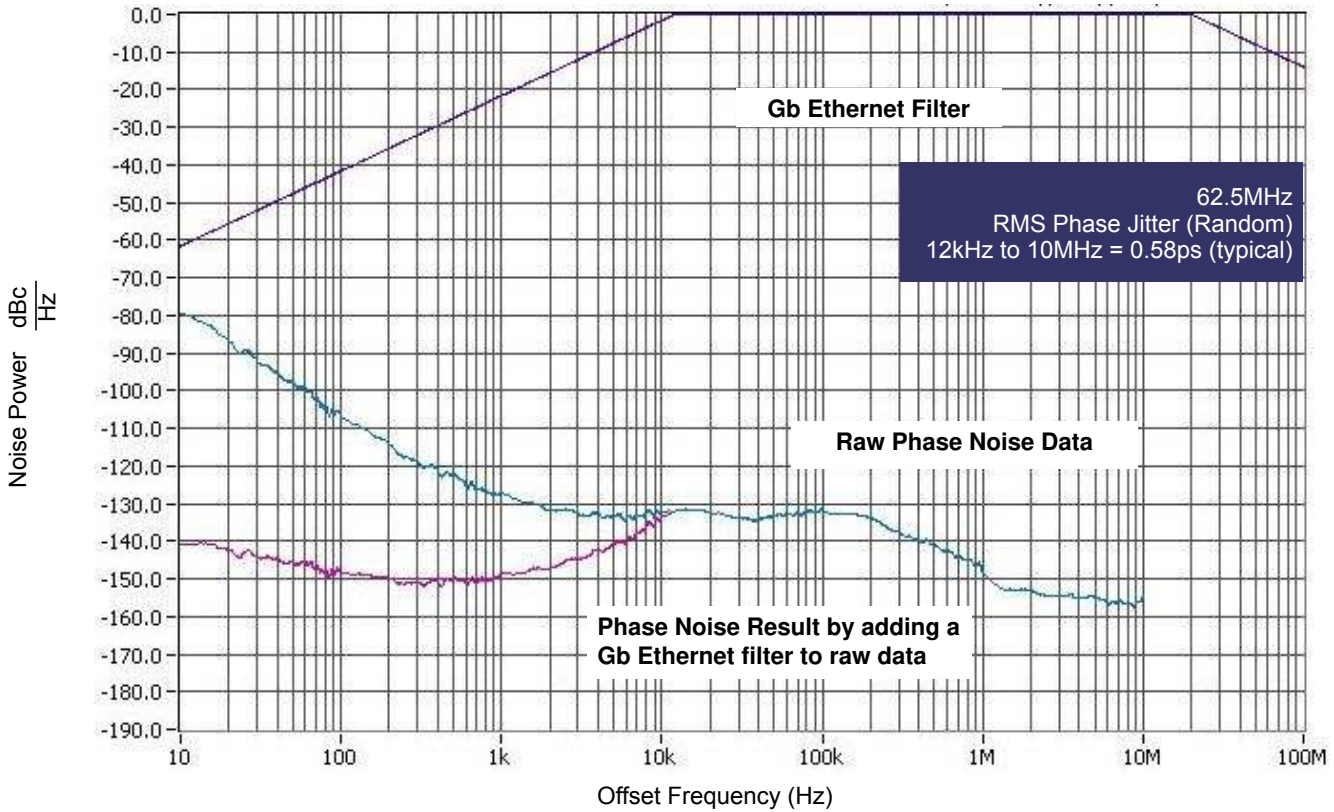

Typical Phase Noise at 125MHz (3.3V)

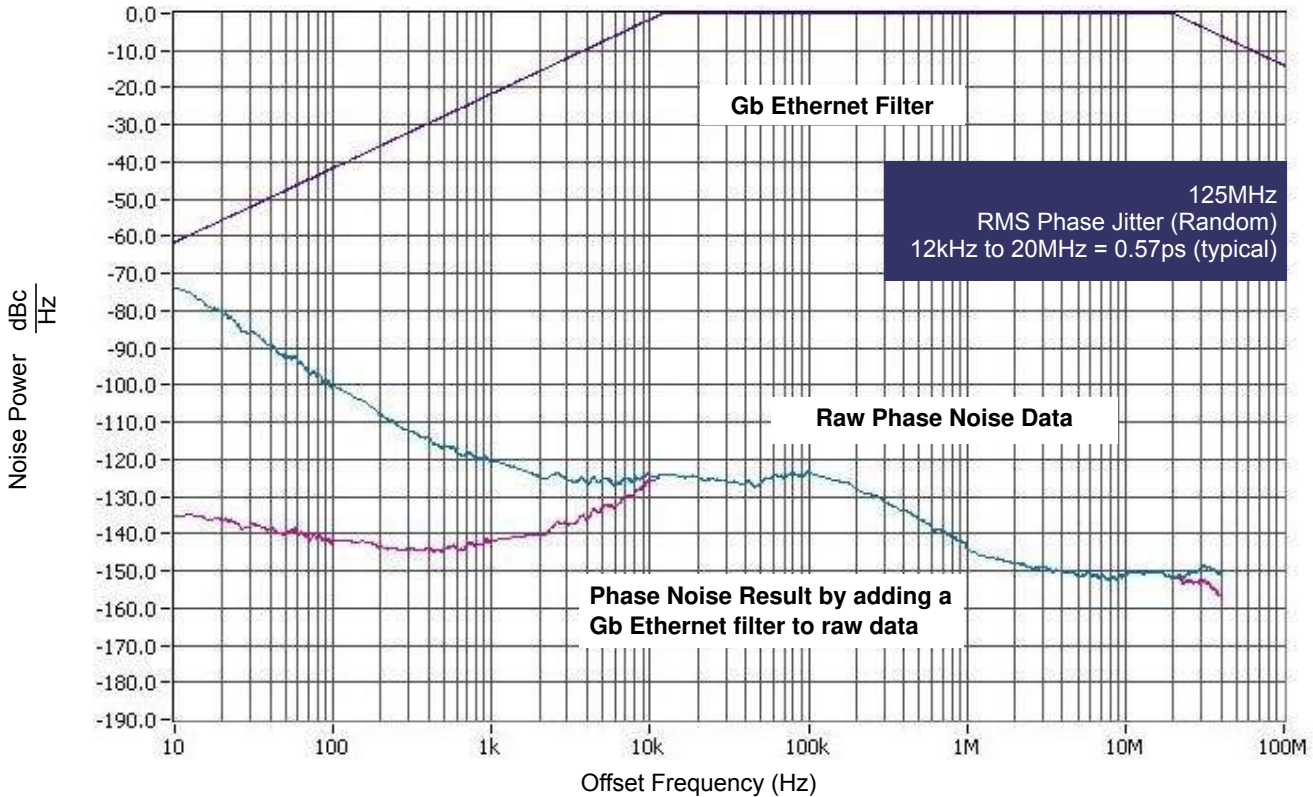

Parameter Measurement Information

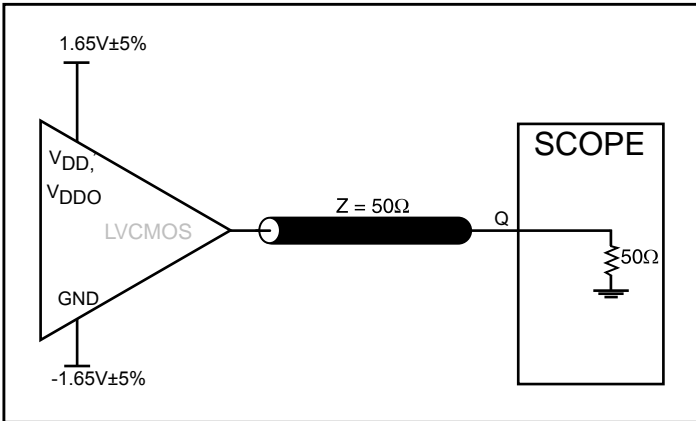

3.3V LVCMOS Output Load AC Test Circuit

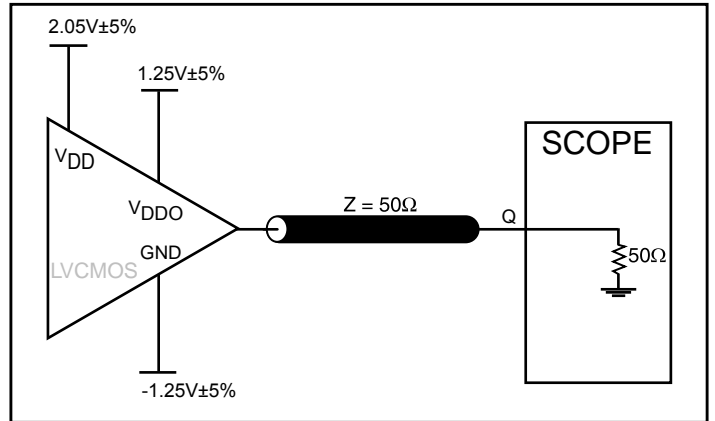

3.3V/2.5V LVCMOS Output Load AC Test Circuit

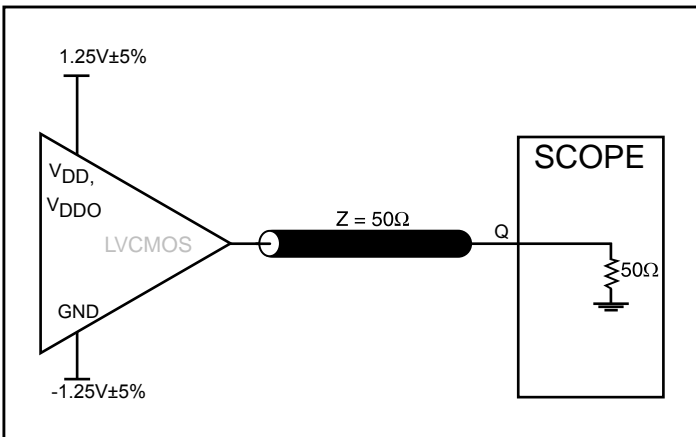

2.5V LVCMOS Output Load AC Test Circuit

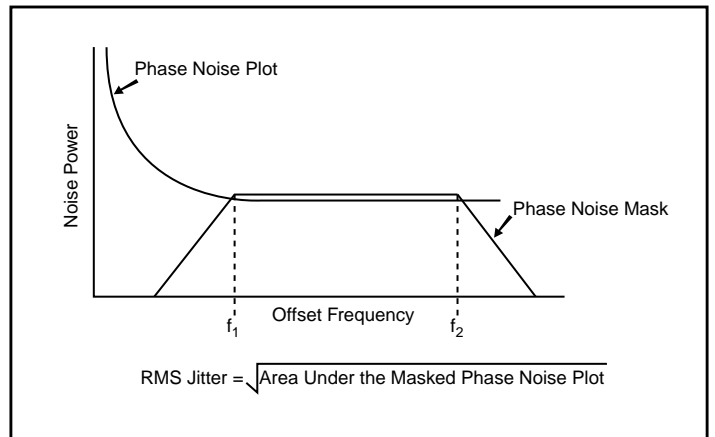

RMS Phase Jitter

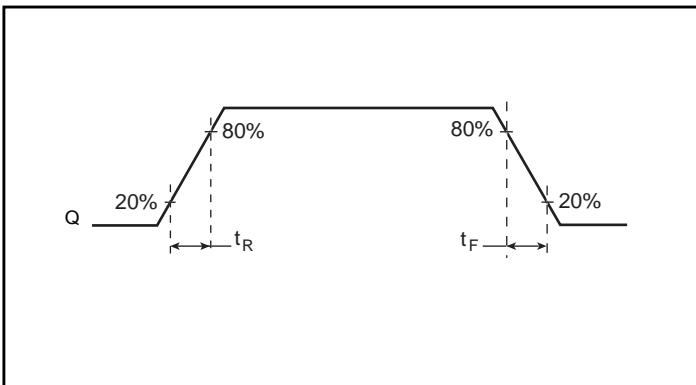

Output Rise/Fall Time

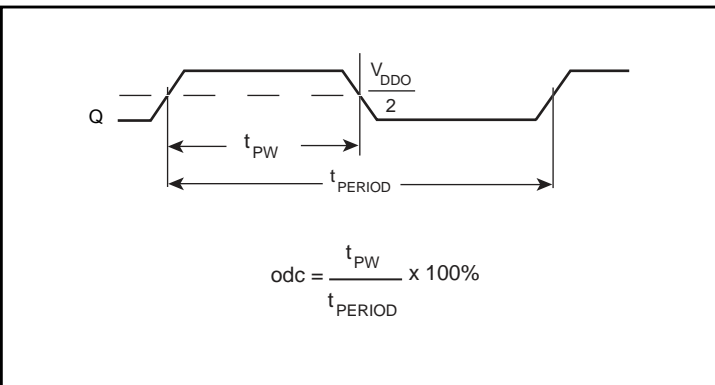

Output Duty Cycle/Pulse Width/Period

Applications Information

Crystal Input Interface

The ICS840022I-02 has been characterized with 18pF parallel resonant crystals. The capacitor values, C1 and C2, shown in *Figure 1* below were determined using a 25MHz, 18pF parallel resonant crystal and were chosen to minimize the ppm error. The optimum C1 and C2 values can be slightly adjusted for different board layouts.

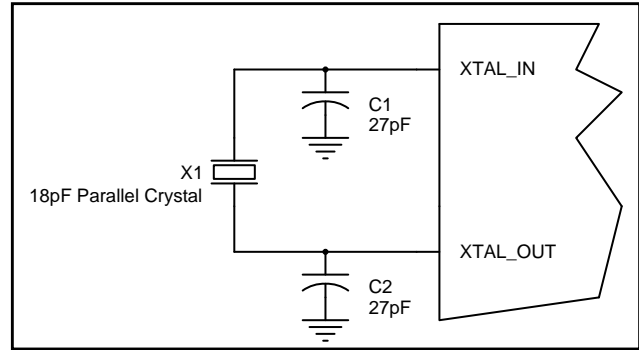

Figure 2. Crystal Input Interface

Overdriving the XTAL Interface

The XTAL_IN input can accept a single-ended LVCMOS signal through an AC coupling capacitor. A general interface diagram is shown in *Figure 2A*. The XTAL_OUT pin can be left floating. The maximum amplitude of the input signal should not exceed 2V and the input edge rate can be as slow as 10ns. This configuration requires that the output impedance of the driver (R_o) plus the series resistance (R_s) equals the transmission line impedance. In addition,

matched termination at the crystal input will attenuate the signal in half. This can be done in one of two ways. First, R1 and R2 in parallel should equal the transmission line impedance. For most 50Ω applications, R1 and R2 can be 100Ω. This can also be accomplished by removing R1 and making R2 50Ω. By overdriving the crystal oscillator, the device will be functional, but note, the device performance is guaranteed by using a quartz crystal.

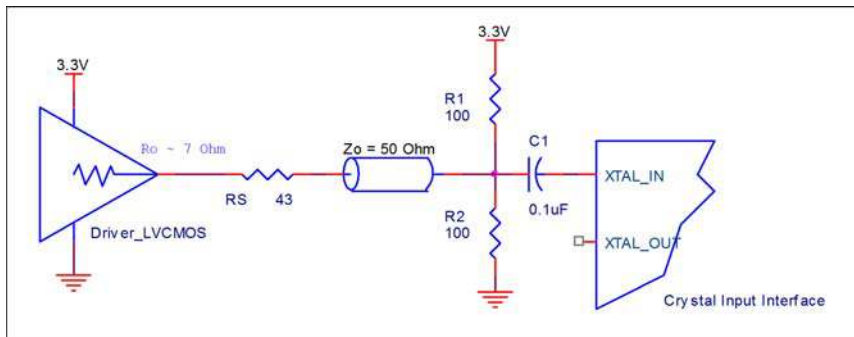

Figure 2A. General Diagram for LVCMOS Driver to XTAL Input Interface

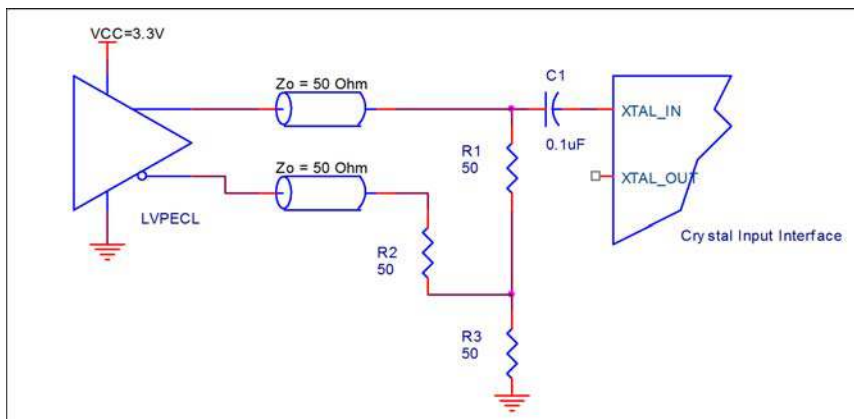

Figure 2B. General Diagram for LVPECL Driver to XTAL Input Interface

Recommendations for Unused Input Pins

Inputs:

LVC MOS Control Pins

The control pins have an internal pullup and pulldown; additional resistance is not required but can be added for additional protection. A 1kΩ resistor can be used.

VFQFN EPAD Thermal Release Path

In order to maximize both the removal of heat from the package and the electrical performance, a land pattern must be incorporated on the Printed Circuit Board (PCB) within the footprint of the package corresponding to the exposed metal pad or exposed heat slug on the package, as shown in *Figure 3*. The solderable area on the PCB, as defined by the solder mask, should be at least the same size/shape as the exposed pad/slug area on the package to maximize the thermal/electrical performance. Sufficient clearance should be designed on the PCB between the outer edges of the land pattern and the inner edges of pad pattern for the leads to avoid any shorts.

While the land pattern on the PCB provides a means of heat transfer and electrical grounding from the package to the board through a solder joint, thermal vias are necessary to effectively conduct from the surface of the PCB to the ground plane(s). The land pattern must be connected to ground through these vias. The vias act as “heat pipes”. The number of vias (i.e. “heat pipes”) are application specific

and dependent upon the package power dissipation as well as electrical conductivity requirements. Thus, thermal and electrical analysis and/or testing are recommended to determine the minimum number needed. Maximum thermal and electrical performance is achieved when an array of vias is incorporated in the land pattern. It is recommended to use as many vias connected to ground as possible. It is also recommended that the via diameter should be 12 to 13mils (0.30 to 0.33mm) with 1oz copper via barrel plating. This is desirable to avoid any solder wicking inside the via during the soldering process which may result in voids in solder between the exposed pad/slug and the thermal land. Precautions should be taken to eliminate any solder voids between the exposed heat slug and the land pattern. Note: These recommendations are to be used as a guideline only. For further information, please refer to the Application Note on the Surface Mount Assembly of Amkor’s Thermally/Electrically Enhance Leadframe Base Package, Amkor Technology.

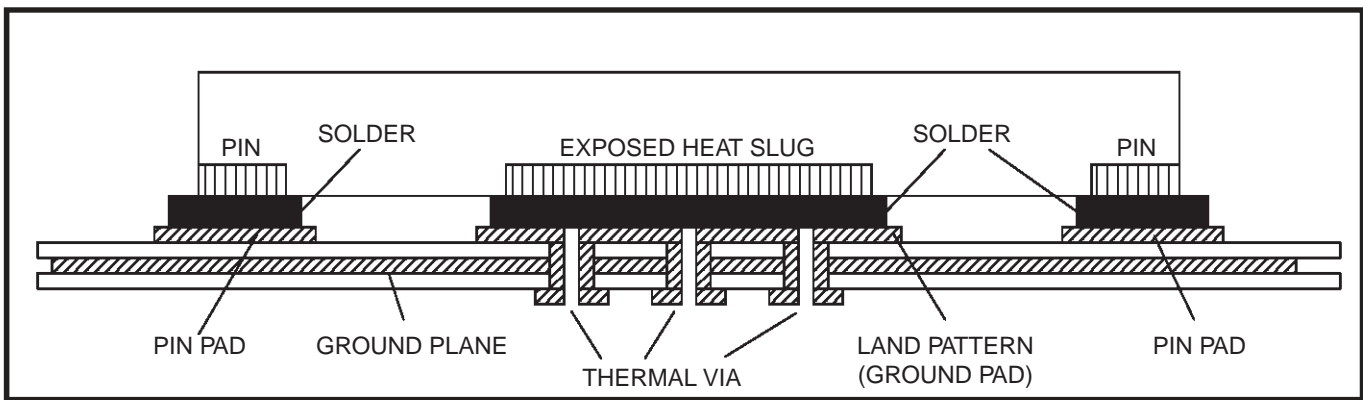

Figure 3. P.C. Assembly for Exposed Pad Thermal Release Path – Side View (drawing not to scale)

Reliability Information

Table 7. θ_{JA} vs. Air Flow Table for a 16 Lead VFQFN

θ_{JA} at 0 Air Flow			
Meters per Second	0	1	2.5
Multi-Layer PCB, JEDEC Standard Test Boards	74.9°C/W	65.5°C/W	58.8°C/W

Transistor Count

The transistor count for ICS840022I-02 is: 1760

Package Outline Drawings (Sheet 1)

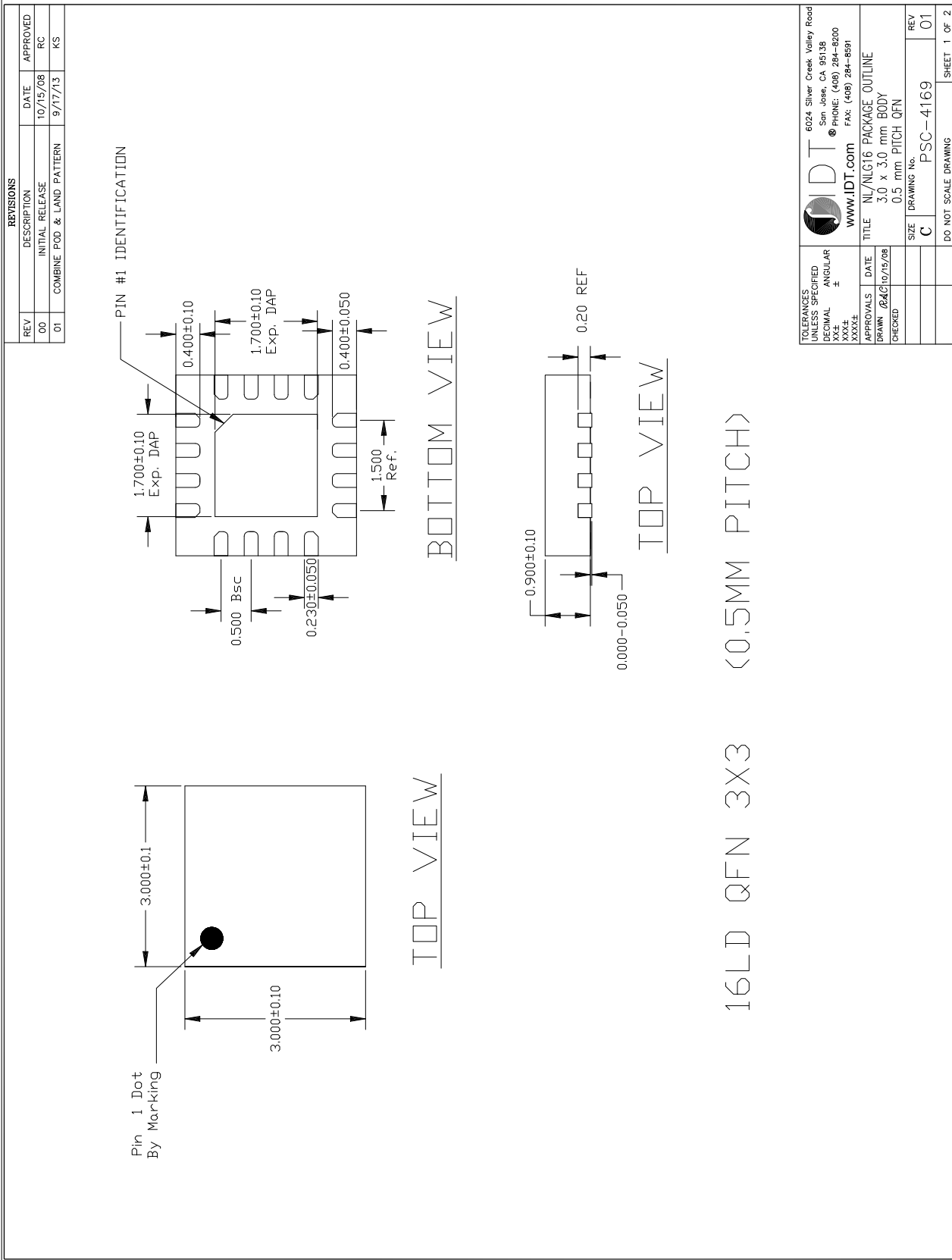

Package Outline Drawings (Sheet 2)

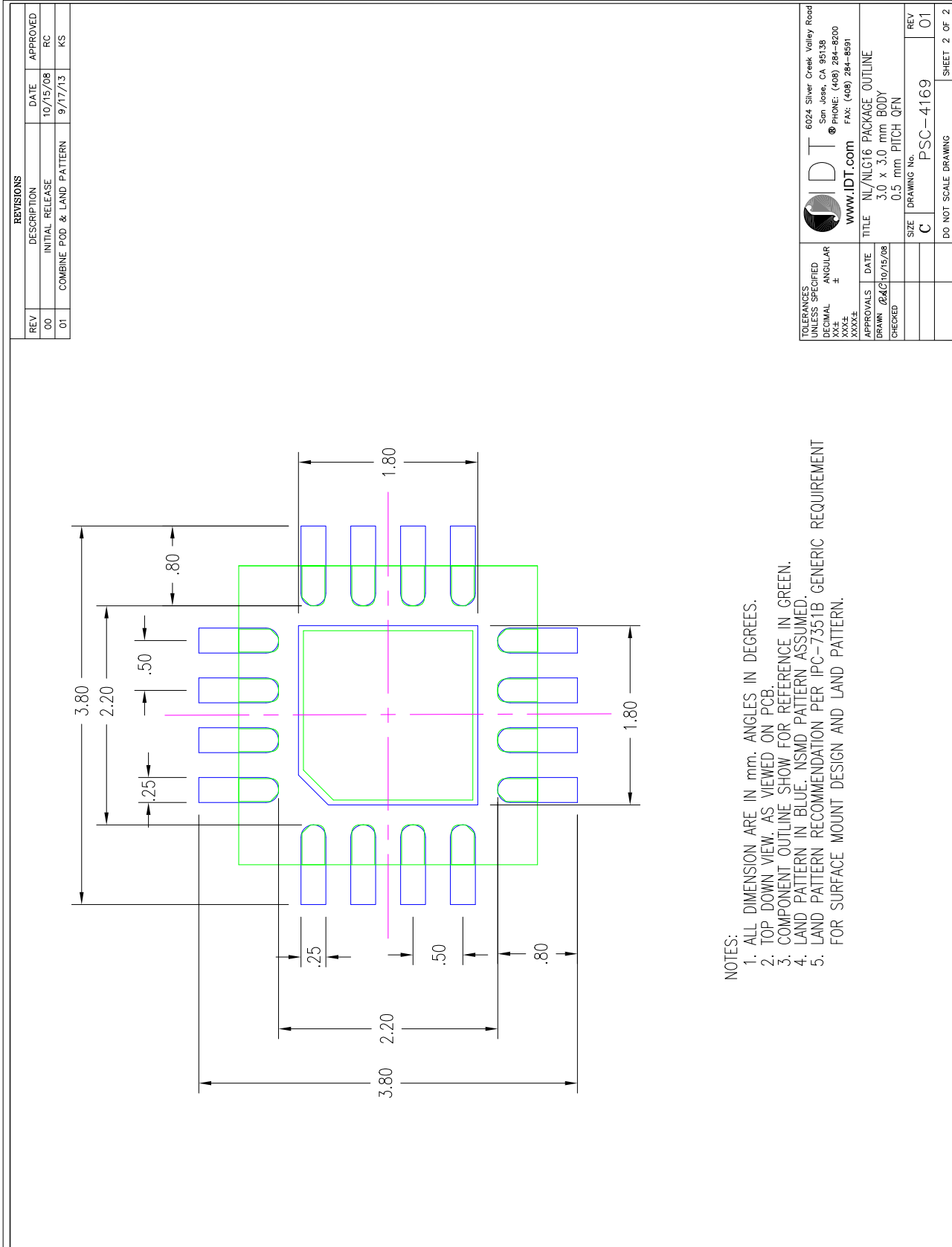

NOTES:

1. ALL DIMENSION ARE IN mm. ANGLES IN DEGREES.
2. TOP DOWN VIEW, AS VIEWED ON PCB.
3. COMPONENT OUTLINE SHOW FOR REFERENCE IN GREEN.
4. LAND PATTERN IN BLUE. NSMD PATTERN ASSUMED.
5. LAND PATTERN RECOMMENDATION PER IPC-7351B GENERIC REQUIREMENT FOR SURFACE MOUNT DESIGN AND LAND PATTERN.

Ordering Information

Table 9. Ordering Information

Part/Order Number	Marking	Package	Shipping Packaging	Temperature
840022AKI-02LF	0I2L	"Lead-Free" 16 Lead VFQFN	Tube	-40°C to 85°C
840022AKI-02LFT	0I2L	"Lead-Free" 16 Lead VFQFN	2500 Tape & Reel	-40°C to 85°C

NOTE: Parts that are ordered with an "LF" suffix to the part number are the Pb-Free configuration and are RoHS compliant.

Revision History Sheet

Rev	Table	Page	Description of Change	Date
A		1 8	Corrected Block Diagram. Updated VFQFN EPAD Thermal Release Path section.	11/7/07
B	T4C T6C	1 3 5 6 8 11	Features Section - added 3.3V/2.5V operating supply. Added 3.3V/2.5V Power Supply DC Characteristics Table. Added 3.3V/2.5V Power Supply AC Characteristics Table. Added 3.3V/2.5V Output Load AC Test Circuit diagram. Updated Overdriving the Crystal Interface. Updated Package Drawing. Converted datasheet format.	7/28/10
B	T9	12	Ordering Information Table - corrected marking from "012L" to "0I2L".	9/27/10
C	-	11/12	Updated the package outline drawings.	5/27/2017

IMPORTANT NOTICE AND DISCLAIMER

RENESAS ELECTRONICS CORPORATION AND ITS SUBSIDIARIES (“RENESAS”) PROVIDES TECHNICAL SPECIFICATIONS AND RELIABILITY DATA (INCLUDING DATASHEETS), DESIGN RESOURCES (INCLUDING REFERENCE DESIGNS), APPLICATION OR OTHER DESIGN ADVICE, WEB TOOLS, SAFETY INFORMATION, AND OTHER RESOURCES “AS IS” AND WITH ALL FAULTS, AND DISCLAIMS ALL WARRANTIES, EXPRESS OR IMPLIED, INCLUDING, WITHOUT LIMITATION, ANY IMPLIED WARRANTIES OF MERCHANTABILITY, FITNESS FOR A PARTICULAR PURPOSE, OR NON-INFRINGEMENT OF THIRD PARTY INTELLECTUAL PROPERTY RIGHTS.

These resources are intended for developers skilled in the art designing with Renesas products. You are solely responsible for (1) selecting the appropriate products for your application, (2) designing, validating, and testing your application, and (3) ensuring your application meets applicable standards, and any other safety, security, or other requirements. These resources are subject to change without notice. Renesas grants you permission to use these resources only for development of an application that uses Renesas products. Other reproduction or use of these resources is strictly prohibited. No license is granted to any other Renesas intellectual property or to any third party intellectual property. Renesas disclaims responsibility for, and you will fully indemnify Renesas and its representatives against, any claims, damages, costs, losses, or liabilities arising out of your use of these resources. Renesas' products are provided only subject to Renesas' Terms and Conditions of Sale or other applicable terms agreed to in writing. No use of any Renesas resources expands or otherwise alters any applicable warranties or warranty disclaimers for these products.

(Disclaimer Rev.1.0 Mar 2020)

Corporate Headquarters

TOYOSU FORESIA, 3-2-24 Toyosu,
Koto-ku, Tokyo 135-0061, Japan
www.renesas.com

Contact Information

For further information on a product, technology, the most up-to-date version of a document, or your nearest sales office, please visit:
www.renesas.com/contact/

Trademarks

Renesas and the Renesas logo are trademarks of Renesas Electronics Corporation. All trademarks and registered trademarks are the property of their respective owners.