

# SMO - 0630S

## Mechanical Drawing

## Stroke / Force Curve

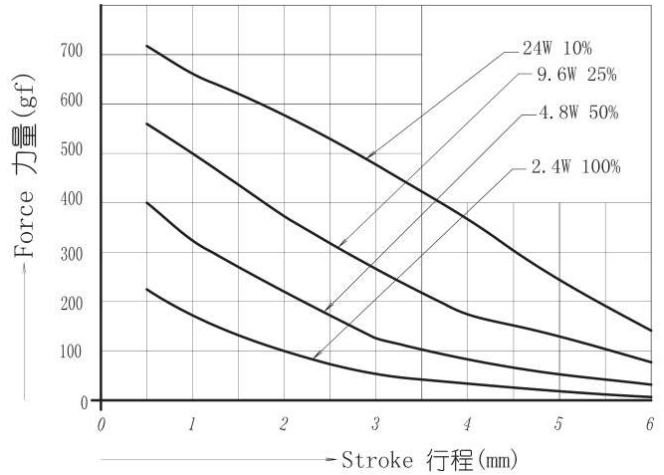
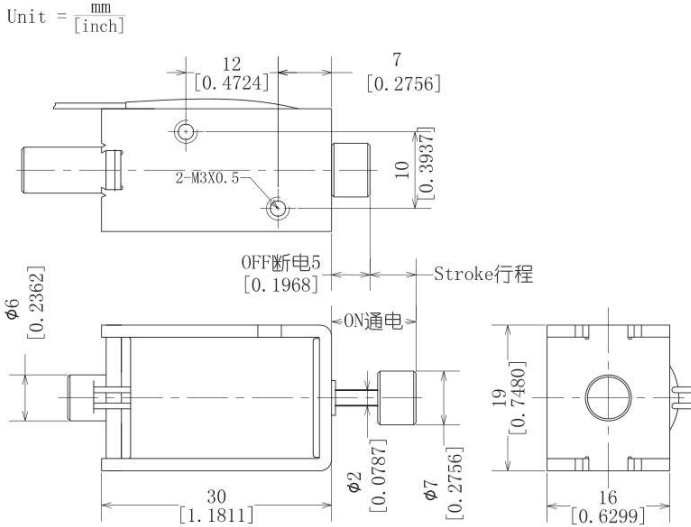

## Stroke / Force Technical Data

Duty cycle (%) = $\frac{\text{"ON" time}}{\text{ON time} + \text{OFF time}} \times 100\%$	100%	50%	25%	10%
	Continuous	Intermittent		
MAX On time/S	$\infty$	55	19	3
Power@20°C	2.4	4.8	9.6	24
Part Number(**: Series number)	DC Resistance( $\Omega \cdot 20^\circ\text{C}$ )			
SMO-0630S-06A**	15	7.5	3.75	1.5
SMO-0630S-12A**	60	30	15	6
SMO-0630S-24A**	240	120	60	24
SMO-0630S-48A**	960	480	240	96