

MAXIM

MAX1473 Evaluation Kit

Evaluates: MAX1473

General Description

The MAX1473 evaluation kit (EV kit) allows for a detailed evaluation of the MAX1473 superheterodyne receiver. It enables testing of the device's RF performance and requires no additional support circuitry. The RF input uses a 50Ω matching network and an SMA connector for convenient connection to test equipment. The EV kit can also directly interface to the user's embedded design for easy data decoding.

The MAX1473 EV kit comes in two versions: a 315MHz version and a 433.92MHz version. The passive components are optimized for these frequencies. These components can easily be changed to work at RF frequencies from 300MHz to 450MHz. In addition, the 5kbps data rate received can be adjusted from 0 to 100kbps by changing two more components.

For easy implementation into the customer's design, the MAX1473 EV kit also features a proven PC board layout, which can be easily duplicated for quicker time-to-market. The EV kit Gerber files are available for download at www.maxim-ic.com.

Features

- ◆ Proven PC Board Layout
- ◆ Proven Components Parts List
- ◆ Multiple Test Points Provided On-Board
- ◆ Available in 315MHz or 433.92MHz Optimized Versions
- ◆ Adjustable Frequency Range from 300MHz to 450MHz*
- ◆ Fully Assembled and Tested
- ◆ Can Operate as a Stand-Alone Receiver with Addition of an Antenna

*Requires component changes

Ordering Information

PART	TEMP RANGE	IC PACKAGE
MAX1473EVKIT-315	-40°C to +85°C	28 TSSOP
MAX1473EVKIT-433	-40°C to +85°C	28 TSSOP

Component List

DESIGNATION	QTY	DESCRIPTION
C1, C2	2	0.01μF ±10% ceramic capacitors (0603) Murata GRM188R71H103KA01
C3	1	1500pF ±10%, 50V X7R ceramic capacitor (0603) Murata GRM188R71H152KA01
C4	1	0.47μF +80% - 20% ceramic capacitor (0603) Murata GRM188F51C474ZA01
C5	1	470pF ±5% ceramic capacitor (0603) Murata GRM1885C1H471JA01
C6, C10	2	220pF ±5% ceramic capacitors (0603) Murata GRM1885C1H221JA01
C7, C8, C11	3	100pF ±5% ceramic capacitors (0603) Murata GRM1885C1H101JA01
C9 (315MHz)	1	4pF ±0.1pF ceramic capacitor (0603) Murata GRM1885C1H4R0BZ01
C9 (433MHz)	1	2.2pF ±0.1pF ceramic capacitor (0603) Murata GRM1885C1H2R2BD01
C12, C20	2	0.1μF ±5% ceramic capacitors (0603) Murata GRM188R71C104KA01
C13, C16, C18, C19	0	Not installed

DESIGNATION	QTY	DESCRIPTION
C14, C15	2	15pF ±5%, 50V ceramic capacitors (0603) Murata GRM1885C1H150JZ01
C17	0	0.01μF +80% - 20% ceramic capacitor (0603), not installed Murata GRM188R71H103KA01
C21	1	0Ω resistor (0603)
F_IN	0	SMA connector edge mount, not installed Johnson 142-0701-801
JU1, JU2, JU5, JU6	4	3-pin headers Digi-Key S1012-36-ND or equivalent
JU7	1	2-pin header
JU3, JU4	0	Not installed
JU8	1	Shorted
—	5	Shunts (JU1) Digi-Key S9000-ND or equivalent
L1 (315MHz)	1	27nH ±5% inductor (0603) Coilcraft 0603CS-27NXJB

MAX1473 Evaluation Kit

Component List (continued)

DESIGNATION	QTY	DESCRIPTION
L1 (433MHz)	1	15nH \pm 5% inductor (0603) Coilcraft 0603CS-15NXJB
L2 (315MHz)	1	120nH \pm 5% inductor (0603) Coilcraft 0603CS-R12XJB
L2 (433MHz)	1	56nH \pm 5% inductor (0603) Coilcraft 0603CS-56NXJB
L3	1	15nH \pm 5% inductor (0603) Murata LQG18HN15NJ00
MIX OUT	0	SMA connector top mount, not installed Digi-Key J500-ND Johnson 142-0701-201
R1	1	5.1k Ω resistor (0603), any
R2, R4, R6	0	Resistor (0603), not installed
R3	0	270 Ω resistor (0603), any, not installed
R5	1	10k Ω resistor (0603), any
R7	1	10pF \pm 5%, 50V ceramic capacitor (0603) Murata GRM1885C1H100JZ01
R8	1	10k Ω resistor (0603), any

Quick Start

The following procedure allows for proper device evaluation.

Required Test Equipment

- Regulated power supply capable of providing +3.3V
- RF signal generator capable of delivering from -120dBm to 0dBm of output power at the operating frequency, in addition to AM or pulse-modulation capabilities (Agilent E4420B or equivalent)
- Optional ammeter for measuring supply current
- Oscilloscope

Connections and Setup

This section provides a step-by-step guide to operating the EV kit and testing the device's functionality. Do not turn on the DC power or RF signal generator until all connections are made:

- 1) Connect a DC supply set to +3.3V (through an ammeter, if desired) to the VDD and GND terminals on the EV kit. Do not turn on the supply.
- 2) Connect the RF signal generator to the RF_IN SMA connector. Do not turn on the generator output. Set the generator for an output frequency of 315MHz (or 433.92MHz) at a power level of -100dBm. Set the modulation of the generator to provide a 2kHz 100%

DESIGNATION	QTY	DESCRIPTION
R9	1	1000pF \pm 10%, 50V X7R ceramic capacitor (0603) Murata GRM188R71H102KA01
RF IN	1	SMA connector top mount Digi-Key J500-ND Johnson 142-0701-201
TP2, TP4–TP12	0	Not installed
VDD, GND, SHDN, DATA_OUT, TP3	5	Test points Mouser 151-203 or equivalent
Y1 (315MHz)	1	Crystal 4.754687MHz Hong Kong Crystal SSL4754687E03FAFZ8A0 or Crystek 016867
Y1 (433MHz)	1	Crystal 6.6128MHz Hong Kong Crystal SSL6612813E03FAFZ8A0 or Crystek 016868
Y2	1	10.7MHz ceramic filter Murata SFTLA10M7FA00-B0
U1	1	MAX1473EUI
—	1	MAX1473 EV kit PC board

AM-modulated square wave (or a 2kHz pulse-modulated signal).

- 3) Connect the oscilloscope to test point TP3.
- 4) Turn on the DC supply. The supply current should read approximately 5mA.
- 5) Activate the RF generator's output without modulation. The scope should display a DC voltage that varies from approximately 1.2V to 2.0V as the RF generator amplitude is changed from -115dBm to 0dBm. (**Note:** At an input amplitude of around -60dBm, this DC voltage will drop suddenly to about 1.5V and then rise again with increasing input amplitude. This is normal; the AGC is turning on the LNA gain reduction resistor).
- 6) Set the RF generator to -100dBm. Activate the RF generator's modulation and set the scope's coupling to AC. The scope now displays a lowpass-filtered square wave at TP3 (filtered analog baseband data). Use the RF generator's LF OUTPUT (modulation output) to trigger the oscilloscope.
- 7) Monitor the DATA_OUT terminal and verify the presence of a 2kHz square wave.

MAX1473 Evaluation Kit

Evaluates: MAX1473

Additional Evaluation

- 1) With the modulation still set to AM, observe the effect of reducing the RF generator's amplitude on the DATA_OUT terminal output. The error in this sliced digital signal increases with reduced RF signal level. The sensitivity is usually defined as the point at which the error in interpreting the data (by the following embedded circuitry) increases beyond a set limit (BER test).
- 2) With the above settings, a 315MHz-tuned EV kit should display a sensitivity of about -117dBm (0.2% BER) while a 433.92MHz kit displays a sensitivity of about -115dBm (0.2% BER). **Note:** The above sensitivity values are given in terms of average peak power is 3dB higher.
- 3) Capacitors C5 and C6 are used to set the corner frequency of the 2nd-order lowpass Sallen-Key data filter. The current values were selected for bit rates up to 5kbps. Adjusting these values accommodates higher data rates (refer to the MAX1473 data sheet for more details).

Layout Issues

A properly designed PC board is an essential part of any RF/microwave circuit. On high-frequency inputs and outputs, use controlled-impedance lines and keep them as short as possible to minimize losses and radiation. At high frequencies, trace lengths that are on the order of $\lambda/10$ or longer can act as antennas.

Keeping the traces short also reduces parasitic inductance. Generally, 1in of a PC board trace adds about 20nH of parasitic inductance. The parasitic inductance can have a dramatic effect on the effective inductance. For example, a 0.5in trace connecting a 100nH inductor adds an extra 10nH of inductance or 10%.

To reduce the parasitic inductance, use wider traces and a solid ground or power plane below the signal traces. Also, use low-inductance connections to ground on all GND pins, and place decoupling capacitors close to all VDD connections.

The EV kit PC board can serve as a reference design for laying out a board using the MAX1473. All required components have been enclosed in a 1.25in \times 1.25in square, which can be directly "inserted" into the application circuit.

Detailed Description

Power-Down Control

The MAX1473 can be controlled externally using the SHDN connector. The IC draws approximately 1.25 μ A in shutdown mode. Jumper JU1 is used to control this mode. The shunt can be placed between pins 2 and 3

for continuous shutdown, or pins 1 and 2 for continuous operation. Remove the JU1 shunt for external control. Table 1 describes jumper functions.

Power Supply

The MAX1473 can operate from 3.3V or 5V supplies. For 5V operation, remove JU7 before connecting the supply to VDD. For 3.3V operation, connect JU7.

IF Input/Output

The 10.7MHz IF can be monitored with the help of a spectrum analyzer using the MIX_OUT SMA connector (not provided). Remove the ceramic filter for such a measurement and include R3 (270 Ω) and C17 (0.01 μ F) to match the 330 Ω mixer output with the 50 Ω spectrum analyzer. Jumper JU3 needs to connect pins 1 and 2. It is also possible to use the MIX_OUT SMA connector to inject an external IF as a means of evaluating the baseband data slicing section. Jumper JU3 needs to connect pins 2 and 3.

F_IN External Frequency Input

For applications where the correct frequency crystal is not available, it is possible to directly inject an external frequency through the F_IN SMA connector (not provided). Connect the SMA connector to a function generator. The addition of C18 and C19 is necessary (use 0.01 μ F capacitors).

AGC Control

Jumper JU5 controls whether the AGC is enabled. Connect pins 2 and 3 to enable the AGC.

Crystal Select

Jumper JU2 controls the crystal divide ratio. Connecting pins 1 and 2 sets the divide ratio to 64, while connecting pins 2 and 3 sets the ratio to 32. This determines the frequency of the crystal to be used.

Image Rejection Frequency Select

A unique feature of the MAX1473 is its ability to vary at which frequency the image rejection is optimized. JU6 allows the selection of three possible frequencies: 315MHz, 375MHz, and 433.92MHz. See Table 1 for settings.

Test Points and I/O Connections

Additional test points and I/O connectors are provided to monitor the various baseband signals and for external connections. See Tables 2 and 3 for a description.

For additional information and a list of application notes, consult the www.maxim-ic.com website.

MAX1473 Evaluation Kit

Table 1. Jumper Functions

JUMPER	STATE	FUNCTION
JU1	1-2	Normal operation
JU1	2-3	Power-down mode
JU1	NC	External power-down control
JU2	2-3	Crystal divide ratio = 32
JU2	1-2	Crystal divide ratio = 64
JU3	1-2	Mixer output to MIX_OUT
JU3	2-3	External IF input
JU3	NC	Normal operation
JU4	1-2	Uses PDOUT for faster receiver startup
JU4	2-3	GND connection for peak detector filter
JU5	1-2	Disables AGC
JU5	2-3	Enables AGC
JU6	1-2	IR centered at 433MHz
JU6	2-3	IR centered at 315MHz
JU6	NC	IR centered at 375MHz
JU7	1-2	Connect VDD to +3.3V supply
JU7	NC	Connect VDD to +5.0V supply

Table 2. Test Points

TP	DESCRIPTION
2	Data slicer negative input
3	Data filter output
4	Peak detector out
5	+3.3V
6	GND
7	Data filter feedback node
8	Data out
9	Power-down select input
10	VDD
11	AGC control
12	Crystal select

Table 3. I/O Connectors

SIGNAL	DESCRIPTION
RF_IN	RF input
F_IN	External reference frequency input
MIX_OUT	IF input/output
GND	Ground
VDD	Supply input
DATA_OUT	Sliced data output
SHDN	External power-down control

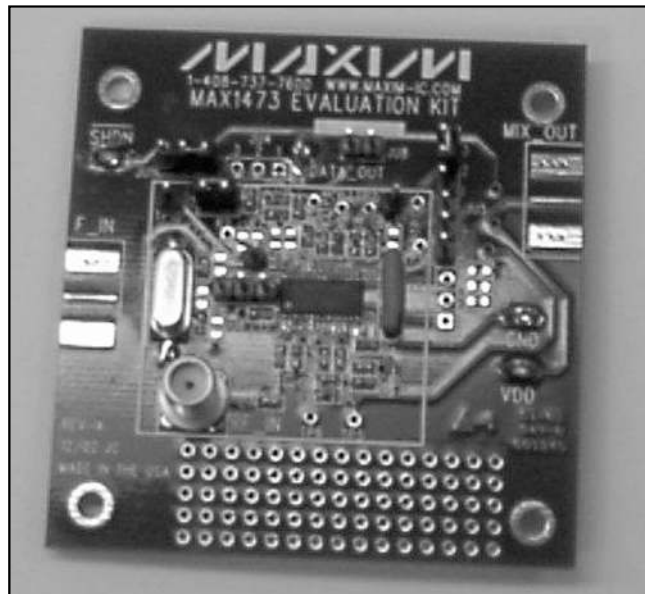

Figure 1. MAX1473 EV Kit

MAX1473 Evaluation Kit

Evaluates: MAX1473

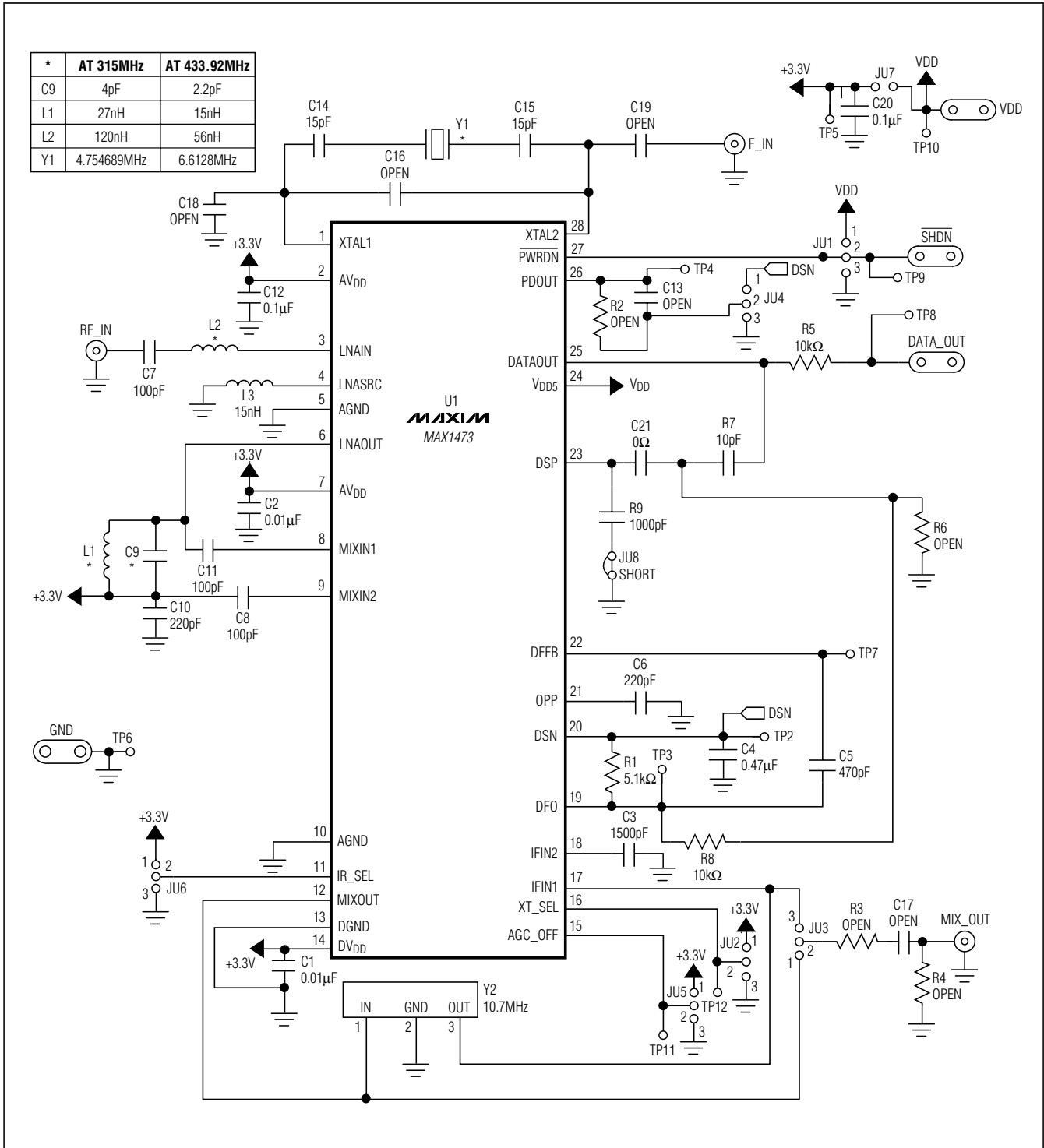

Figure 2. MAX1473 EV Kit Schematic

MAX1473 Evaluation Kit

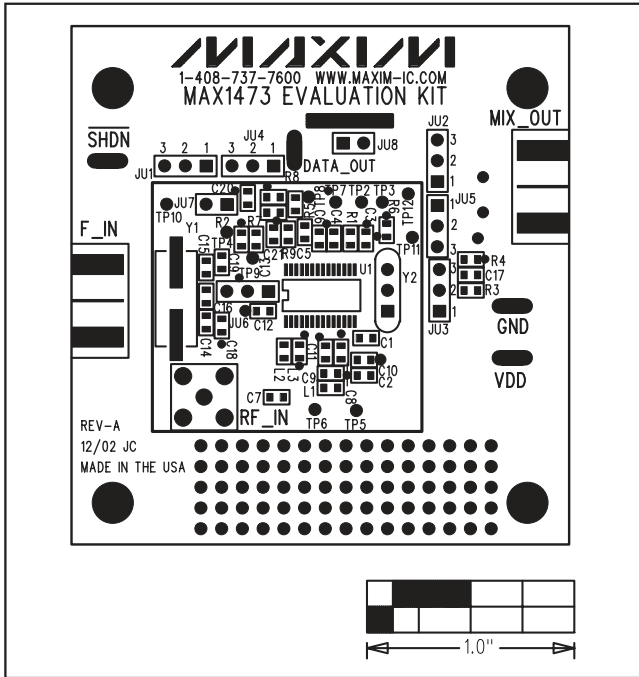

Figure 3. MAX1473 EV Kit Component Placement Guide—Component Side

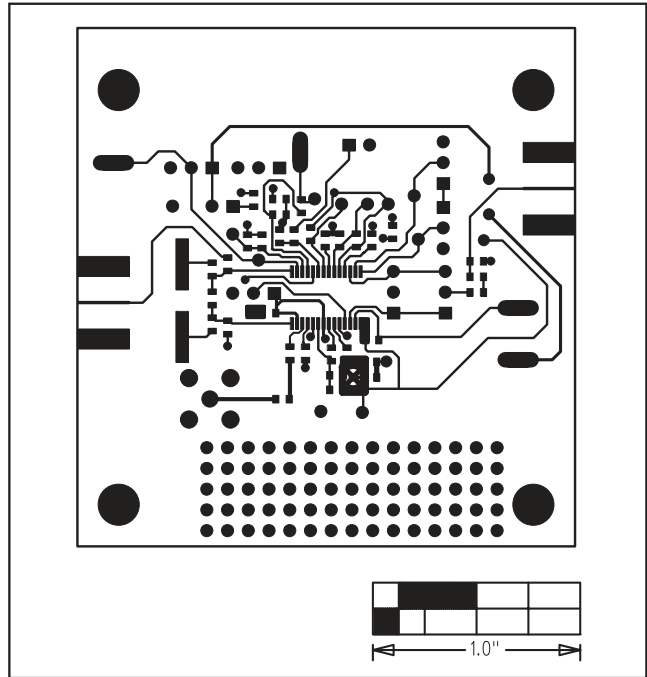

Figure 4. MAX1473 EV Kit PC Board Layout—Component Side

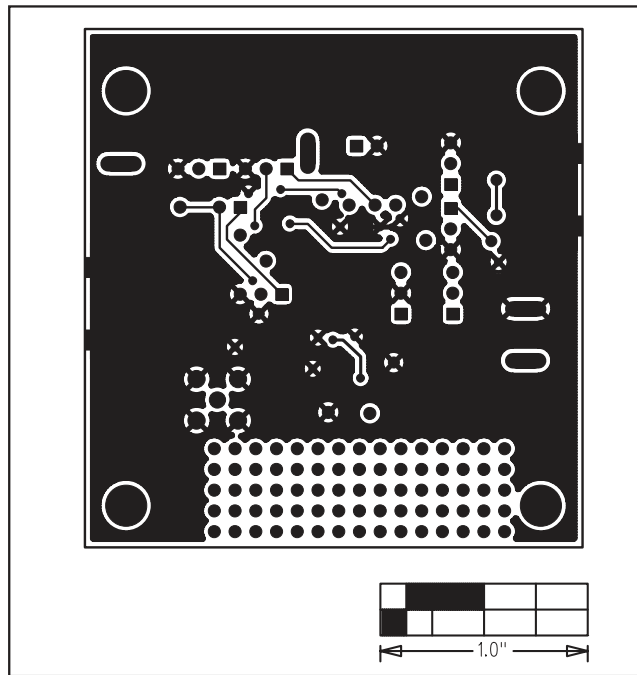

Figure 5. MAX1473 EV Kit PC Board Layout—Solder Side

Maxim cannot assume responsibility for use of any circuitry other than circuitry entirely embodied in a Maxim product. No circuit patent licenses are implied. Maxim reserves the right to change the circuitry and specifications without notice at any time.

6 **Maxim Integrated Products, 120 San Gabriel Drive, Sunnyvale, CA 94086 408-737-7600**