

ASMT-QWBF-NKL0E, ASMT-QWBF-NKLAE

Super 0.5 W Cool White Power PLCC-4 Surface Mount LED Indicator



Description

The Broadcom[®] Super 0.5 W Cool White Power PLCC-4 SMT LED is using InGaN chip technology. The package can be driven at high current due to its superior package design. The product is able to dissipate the heat more efficiently compared to the Power PLCC-4 SMT LEDs. These LEDs produce higher light output with better flux performance compared to the Power PLCC-4 SMT LED.

The Super 0.5 W Cool White Power PLCC-4 SMT LEDs are designed for higher reliability, better performance, and operate under a wide range of environmental conditions.

To facilitate easy pick-and-place assembly, the LEDs are packed in EIA-compliant tape and reel. Every reel is shipped in single intensity and color bin, to provide close uniformity.

Features

- Industry Standard PLCC 4 platform (3.2 × 2.8 × 1.9 mm³)
- High reliability package with enhanced silicone resin encapsulation
- High brightness with optimum flux performance using InGaN chip technologies
- Available in Cool White
- Available in 8-mm carrier tape and 7-in. reel
- Wide viewing angle at 120 degrees
- JEDEC MSL 2

Applications

- Interior automotive
 - Instrument panel backlighting
 - Central console backlighting
 - Navigation and audio system backlighting
 - Dome/Map lighting
 - Push button backlighting
 - Puddle lamp
 - Glove compartment illumination
- Electronic signs and signals
 - Decorative lighting
- Office automation, home appliances, industrial equipment
 - Panel/button backlighting
 - Display backlighting
- Others
 - Illuminations
 - Advertising board Back lighting

CAUTION! LEDs are Class 2 ESD sensitive. Please observe appropriate precautions during handling and processing.

Package Drawing

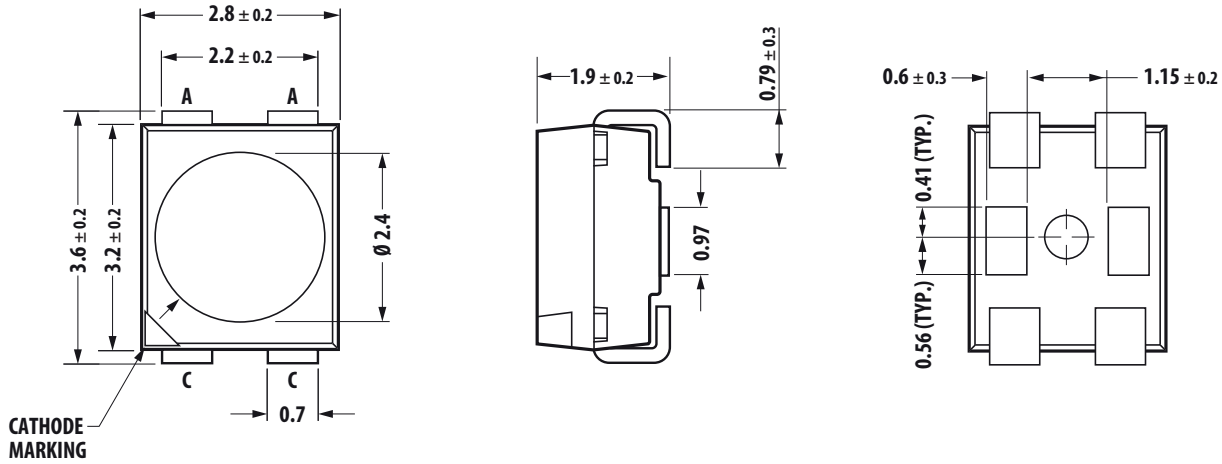

- Notes:
1. All dimensions in millimeters.
 2. Terminal finish: ag plating.
 3. Encapsulation material: silicone resin.

Device Selection Guide ($T_J = 25^\circ\text{C}$)

Color	Part Number	Luminous Flux, θ_v^a (lm)			Test Current (mA)	Dice Technology
		Min.	Typ.	Max.		
Cool White	ASMT-QWBF-NKL0E	43	49	73	150	InGaN
Cool White	ASMT-QWBF-NKLAE	43	49	73	150	InGaN

a. θ_v is the total luminous flux output as measured with an integrating sphere at mono pulse conditions.

NOTE: Tolerance $\pm 12\%$.

Part Numbering System

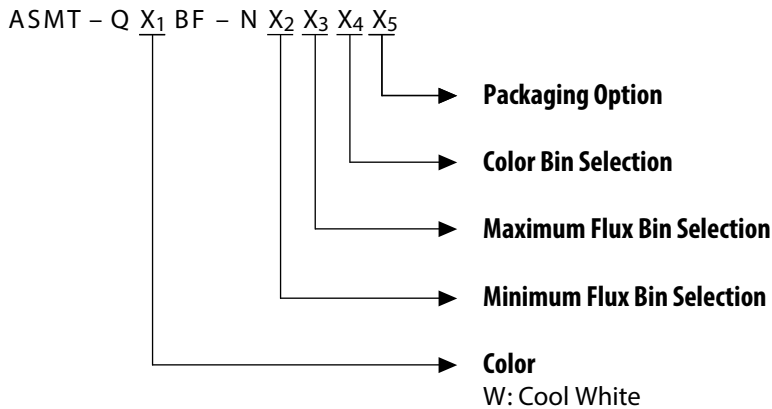

Absolute Maximum Ratings ($T_A = 25^\circ\text{C}$)

Parameter	Rating	Units
DC Forward Current	150	mA
Peak Forward Current ^a	300	mA
Power Dissipation	570	mW
Reverse Voltage	Not Recommended	V
Junction Temperature	125	$^\circ\text{C}$
Operating Temperature	-40 to +120	$^\circ\text{C}$
Storage Temperature	-40 to +120	$^\circ\text{C}$

a. Duty Factor = 10%, Frequency = 1 kHz.

Optical Electrical Characteristics ($T_J = 25^\circ\text{C}$, $I_F = 150\text{ mA}$)

CCT (K)	Viewing Angle $2\theta_{1/2}$ ^a (Degree)	Luminous Efficiency η_e (lm/W)	Forward Voltage V_F (Volt)		Thermal Resistance $R\theta_{J-P}$ ($^\circ\text{C}/\text{W}$)
	Typ.	Typ.	Typ.	Max.	
4500 ~ 10000	120	94	3.30	3.50	50

a. $\theta_{1/2}$ is the off-axis angle where the luminous intensity is $1/2$ the peak intensity.

Figure 1: Relative Luminous Flux vs. Forward Current

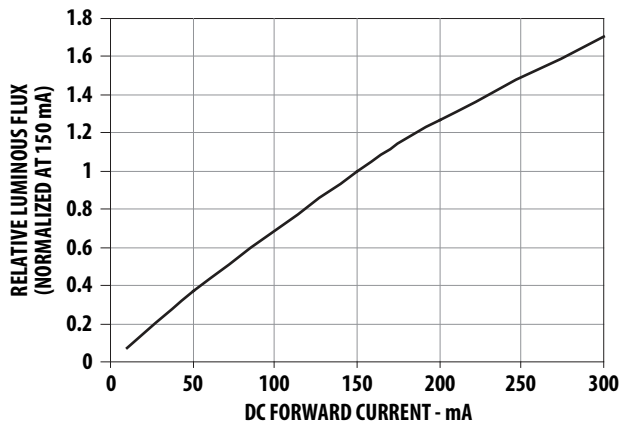

Figure 2: Color Spectrum

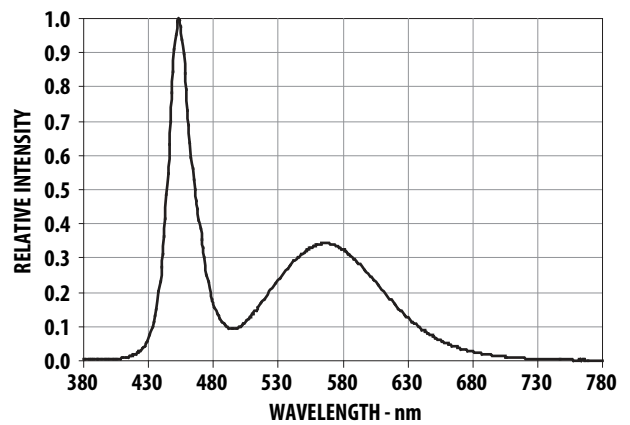

Figure 3: Radiation Pattern

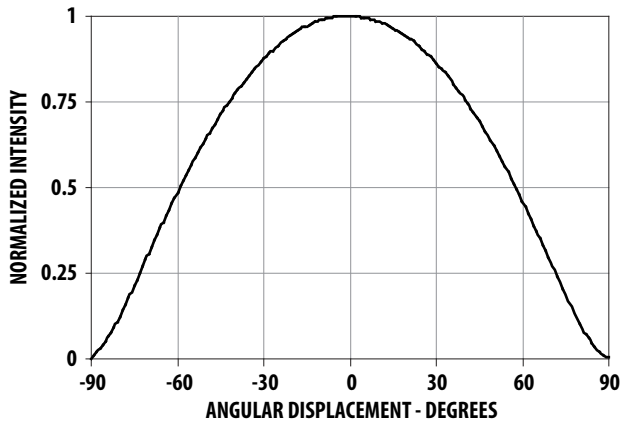

Figure 4: Forward Current vs. Forward Voltage

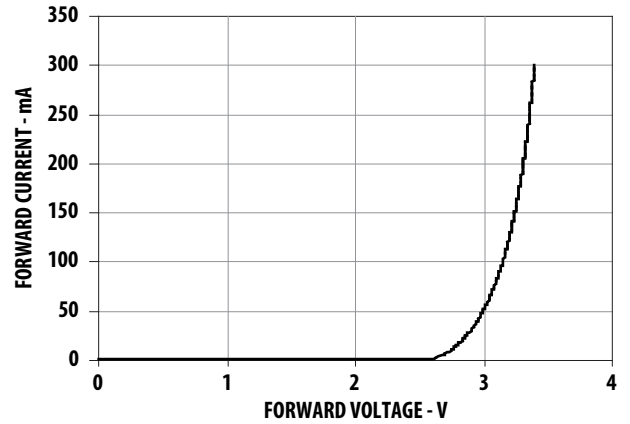

Figure 5: Relative Flux vs. Temperature

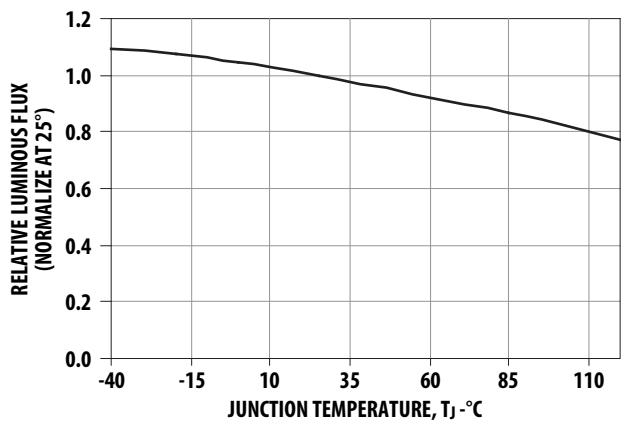

Figure 6: Chromaticity Shift vs. Forward Current

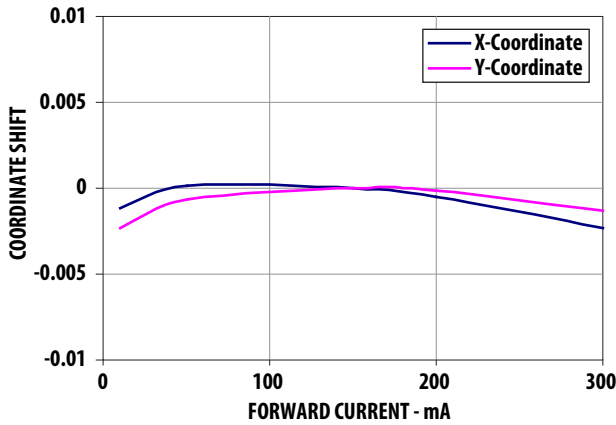

Figure 7: Chromaticity Shift vs. Temperature

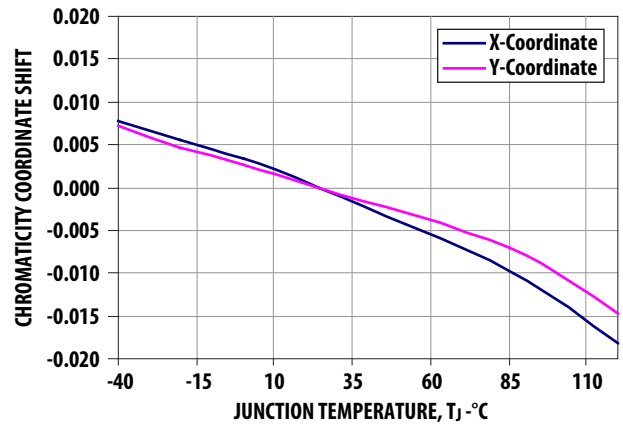

Figure 8: Relative Forward Voltage Shift vs. Temperature

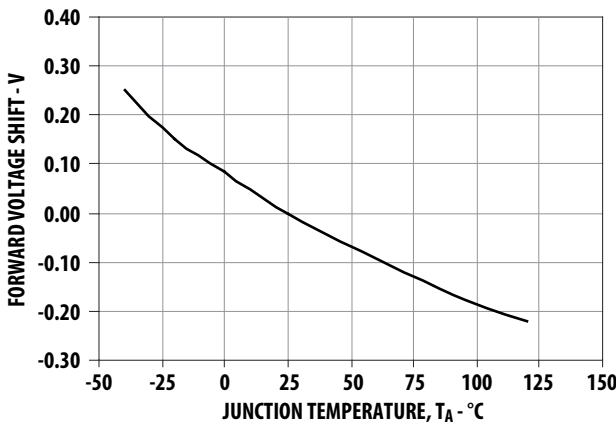

Figure 9: Maximum Forward Current vs. Ambient Temperature. Derated base on $T_{j\max}$ 125°C, $R\theta_{ja}$ 150°C/W.

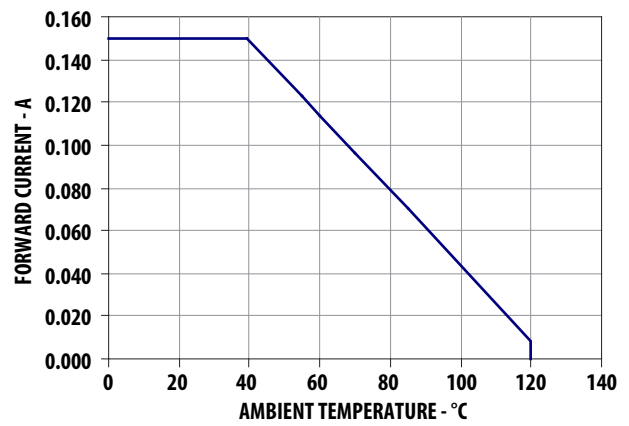

Figure 10: Maximum Pulse Current vs. Ambient Temperature $T_A = 25^\circ\text{C}$

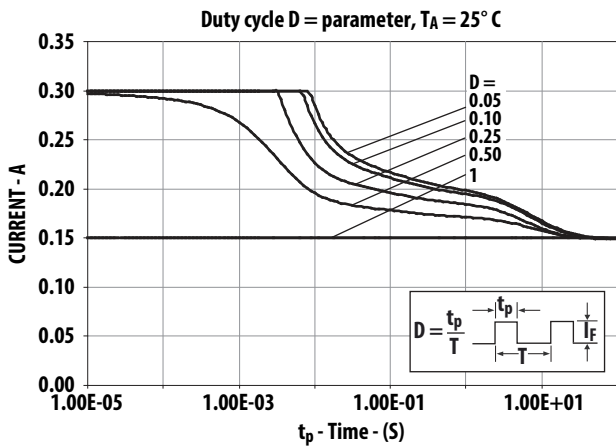

Figure 11: Maximum Pulse Current vs. Ambient Temperature $T_A = 85^\circ\text{C}$

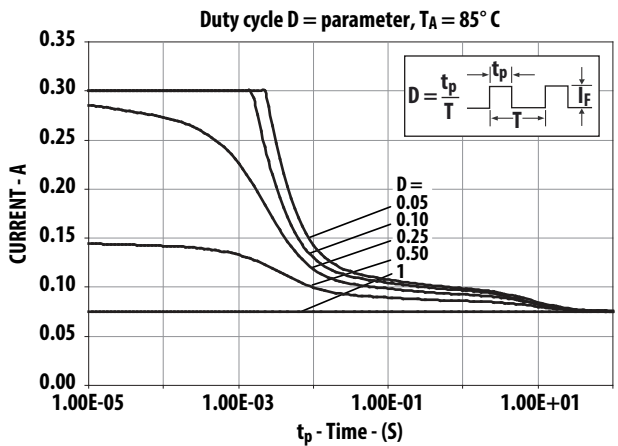
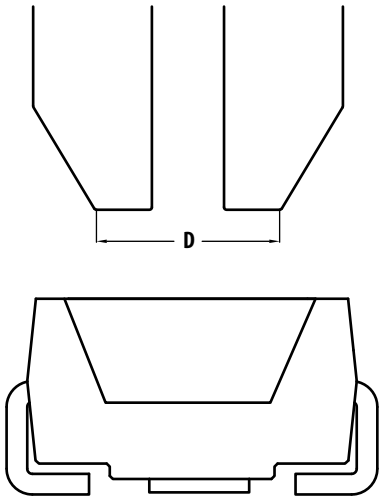

Figure 12: Recommended Pick-and-Place Nozzle Size



Note: Diameter "D" should be smaller than 2.2 mm SMT LED Indicator Components

Figure 13: Recommended Pb Free Reflow Soldering Profile

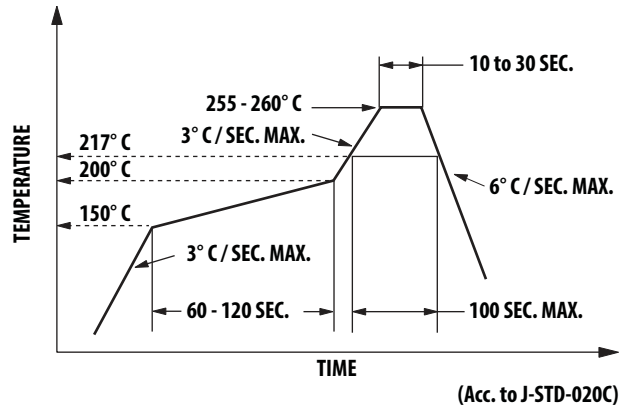

Figure 14: Recommended Soldering Pad Pattern

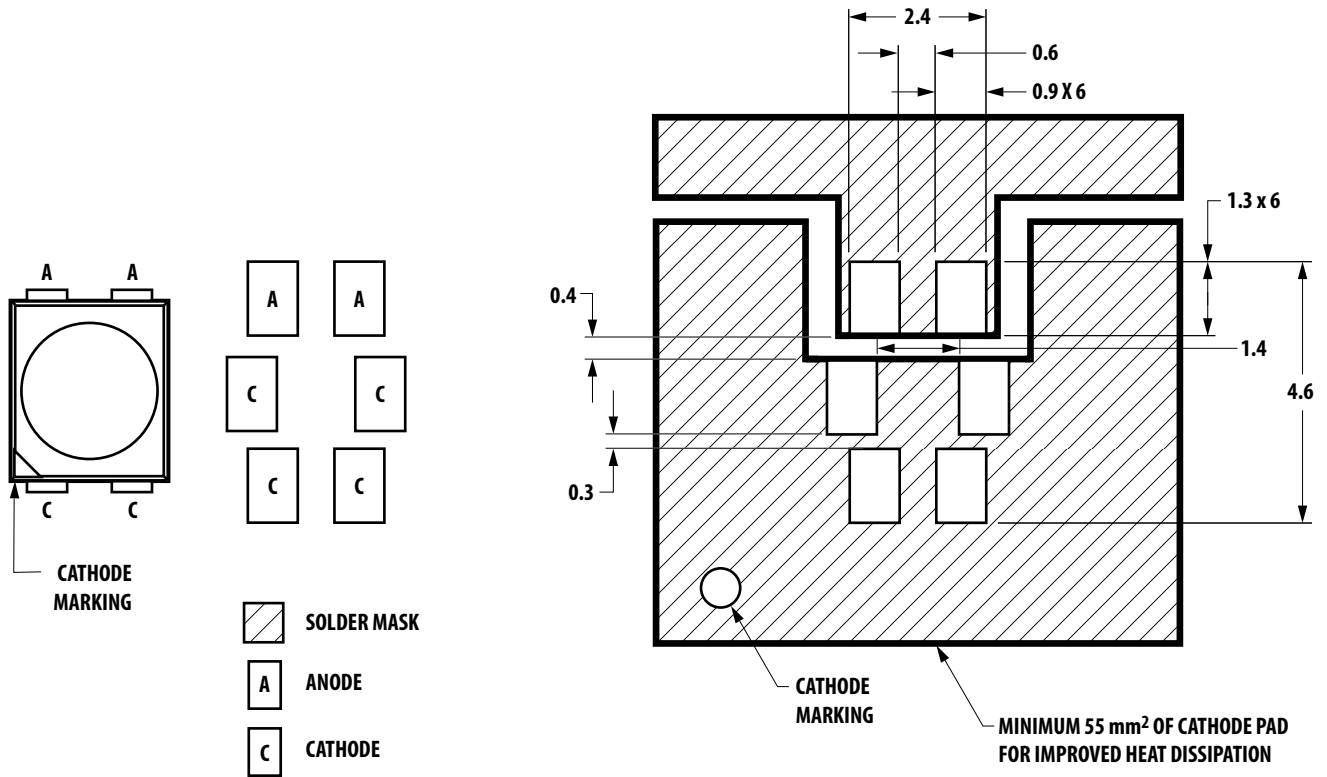

Figure 15: Tape Leader and Trailer Dimensions

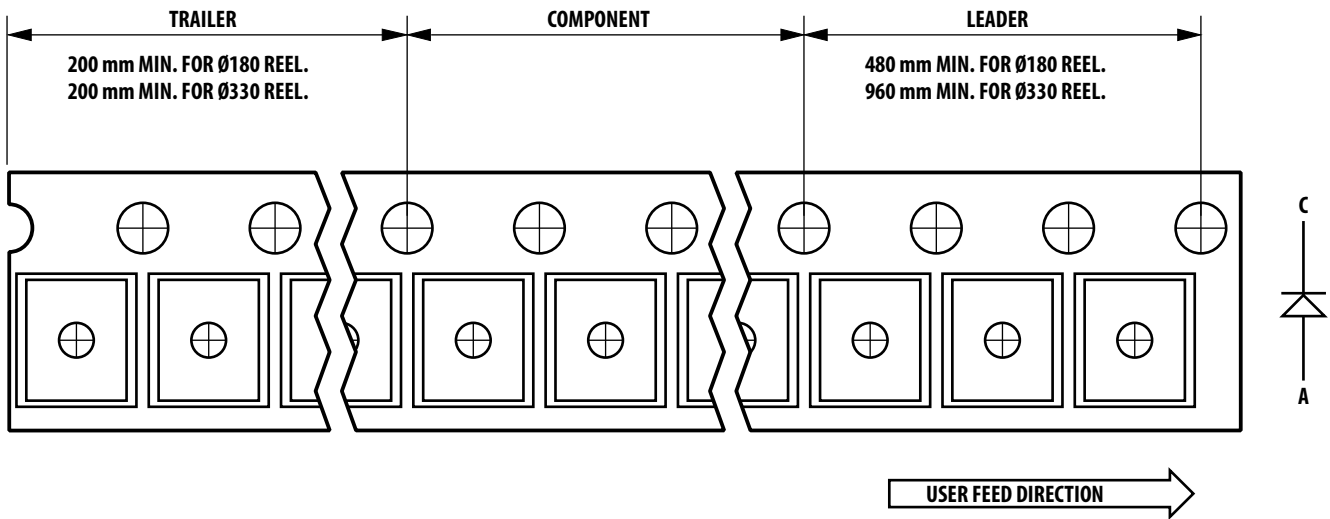
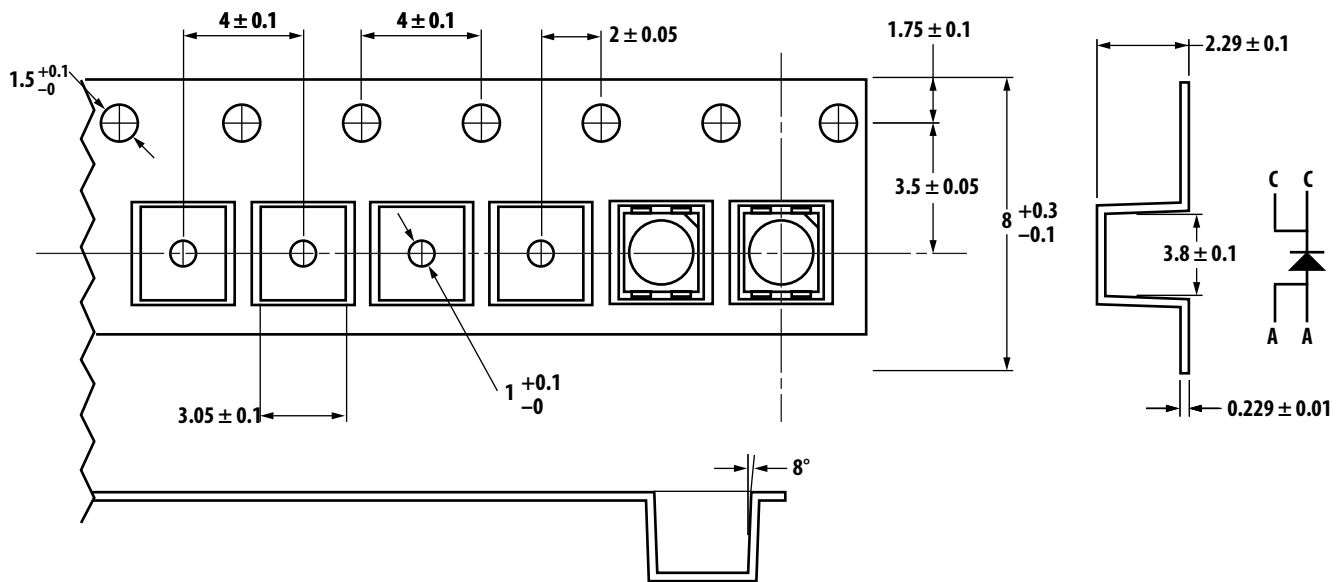

Figure 16: Tape Dimensions



Handling Precaution

The encapsulation material of the product is made of silicone for better reliability of the product. As silicone is a soft material, do not press on the silicone or poke a sharp object onto the silicone. This might damage the product and cause premature failure. During assembly or handling, hold the unit should on the body only. Refer to Broadcom Application Note AN 5288 for detailed information.

Moisture Sensitivity

This product is qualified as Moisture Sensitive Level 2a per JEDECJ-STD-020. Taking precautions when handling this moisture-sensitive product is important to ensure the reliability of the product. Refer to Broadcom Application Note AN 5305 *Handling of Moisture Sensitive Surface Mount Devices* for details.

Storage before use:

- Store the unopened moisture barrier bag (MBB) at $40^{\circ}\text{C}/90\% \text{ RH}$ for 12 months. If the actual shelf life has exceeded 12 months and the humidity indicator card (HIC) indicates that baking is not required, it is safe to reflow the LEDs per the original MSL rating.
- Do not open the MBB prior to assembly (for example, for IQC).

Control after opening the MBB:

- Read the HIC immediately upon opening of MBB.
- Keep the LEDs at $30^{\circ}\text{C}/60\% \text{ RH}$ at all times, and all high-temperature-related processes, including soldering, curing, or rework, must be completed within 672 hours.

Control for unfinished reel:

Unused LEDs must be stored in a sealed MBB with desiccant or desiccator at $5\% \text{ RH}$.

Control of assembled boards:

If the PCB that is soldered with the LEDs is to be subjected to other high-temperature processes, the PCB must be stored in a sealed MBB with desiccant or desiccator at $5\% \text{ RH}$ to ensure that no LEDs have exceeded their floor life of 672 hours.

Baking is required if the following conditions apply:

- The HIC indicator is not GREEN at 10% and is AZURE at 5%
- The LEDs are exposed to conditions of $30^{\circ}\text{C}/60\% \text{ RH}$ at any time.
- The LEDs' floor life exceeded 672 hours.
- Recommended baking condition: $60^{\circ}\text{C} \pm 5^{\circ}\text{C}$ for 20 hours.

Use of LEDs

Do not use materials that contain corrosive substances, such as sulfur, with the LED during the assembly process and application. Silicone is permeable for gases, so corrosive gases will permeate into the LED and corrode the leadframe plating, resulting in open contact.

Application Precautions

- The drive current of the LED must not exceed the maximum allowable limit across temperature as stated in the data sheet. Constant current driving is recommended to ensure consistent performance.
- Circuit design must cater to the whole range of forward voltage (V_F) of the LEDs to ensure the intended drive current can always be achieved.
- The LED exhibits slightly different characteristics at different drive currents, which may result in a larger variation of performance (meaning: intensity, wavelength, and forward voltage). Set the application current as close as possible to the test current to minimize these variations.
- Do not use the LED in the vicinity of material with sulfur content or in environments of high gaseous sulfur compounds and corrosive elements. Examples of materials that might contain sulfur are rubber gaskets, room-temperature vulcanizing (RTV) silicone rubber, rubber gloves, and so on. Prolonged exposure to such environments may affect the optical characteristics and product life.
- White LEDs must not be exposed to acidic environments and must not be used in the vicinity of any compound that may have acidic outgas, such as, but not limited to, acrylate adhesive. These environments have an adverse effect on LED performance.
- Avoid rapid change in ambient temperatures, especially in high-humidity environments, because they cause condensation on the LED.
- If the LED is intended to be used in harsh or outdoor environments, protect the LED against damages caused by rain water, water, dust, oil, corrosive gases, external mechanical stresses, and so on.

Device Color (X₁)

W	Cool White
---	------------

Flux Bin Select (X₂X₃)

Individual reel will contain parts from one bin only.

X ₂	Min Flux Bin
X ₃	Max Flux Bin

Flux Bin

Bin ID	Min. (lm)	Max. (lm)
O	3.40	4.30
A	4.30	5.50
B	5.50	7.00
C	7.00	9.00
D	9.00	11.50
E	11.50	15.00
F	15.00	19.50
G	19.50	25.50
H	25.50	33.00
J	33.00	43.00
K	43.00	56.00
L	56.00	73.00

Tolerance ± 12%.

Color Bin Select (X₄)

Individual reel will contain parts from one sub bin only.

X ₄	
0	Full Distribution
A	5K and 5L only
B	6K and 6L only
C	7K and 7L only
D	8K and 8L only
E	5K and 6K only
F	5L and 6L only
G	6K and 7K only
H	6L and 7L only
J	7K and 8K only
K	7L and 8L only
L	5K, 5L, 6K and 6L only
M	6K, 6L, 7K and 7L only
N	7K, 7L, 8K and 8L only
P	5L only
Q	6L only
R	7L only
S	8L only
T	5K only
U	6K only
V	7K only
W	8K only
Z	Special binning

Color Bin

Table 1: Color Bin

Bin ID	Sub Bin ID	Chromaticity Coordinates				
5K	5Ka	x	0.296	0.304	0.302	0.294
		y	0.259	0.270	0.276	0.264
	5Kb	x	0.294	0.302	0.300	0.291
		y	0.264	0.276	0.281	0.268
	5Kc	x	0.304	0.313	0.312	0.302
		y	0.270	0.284	0.291	0.276
	5Kd	x	0.302	0.312	0.310	0.300
		y	0.276	0.291	0.297	0.281
5L	5La	x	0.291	0.300	0.298	0.288
		y	0.268	0.281	0.288	0.274
	5Lb	x	0.288	0.298	0.295	0.285
		y	0.274	0.288	0.294	0.279
	5Lc	x	0.300	0.310	0.309	0.298
		y	0.281	0.297	0.305	0.288
	5Ld	x	0.298	0.309	0.307	0.295
		y	0.288	0.305	0.312	0.294
6K	6Ka	x	0.313	0.322	0.321	0.312
		y	0.284	0.297	0.305	0.291
	6Kb	x	0.312	0.321	0.320	0.310
		y	0.291	0.305	0.314	0.297
	6Kc	x	0.322	0.330	0.330	0.321
		y	0.297	0.310	0.320	0.305
	6Kd	x	0.321	0.330	0.330	0.320
		y	0.305	0.320	0.330	0.314
6L	6La	x	0.310	0.320	0.319	0.309
		y	0.297	0.314	0.322	0.305
	6Lb	x	0.309	0.319	0.318	0.307
		y	0.305	0.322	0.329	0.312
	6Lc	x	0.320	0.330	0.330	0.319
		y	0.314	0.330	0.339	0.322
	6Ld	x	0.319	0.330	0.330	0.318
		y	0.322	0.339	0.347	0.329
7K	7Ka	x	0.330	0.336	0.337	0.330
		y	0.310	0.320	0.330	0.320
	7Kb	x	0.330	0.337	0.337	0.330
		y	0.320	0.330	0.341	0.330
	7Kc	x	0.336	0.343	0.344	0.337
		y	0.320	0.331	0.341	0.330
	7Kd	x	0.337	0.344	0.345	0.337
		y	0.330	0.341	0.352	0.341

Table 1: Color Bin (Continued)

Bin ID	Sub Bin ID	Chromaticity Coordinates				
		x	y	z	u	v
7L	7La	x	0.330	0.337	0.337	0.330
		y	0.330	0.341	0.349	0.339
	7Lb	x	0.330	0.337	0.338	0.330
		y	0.339	0.349	0.358	0.347
	7Lc	x	0.337	0.345	0.346	0.337
		y	0.341	0.352	0.362	0.349
	7Ld	x	0.337	0.346	0.347	0.338
		y	0.349	0.362	0.371	0.358
8K	8Ka	x	0.343	0.351	0.352	0.344
		y	0.331	0.343	0.354	0.341
	8Kb	x	0.344	0.352	0.354	0.345
		y	0.341	0.354	0.364	0.352
	8Kc	x	0.351	0.360	0.362	0.352
		y	0.343	0.357	0.369	0.354
	8Kd	x	0.352	0.362	0.364	0.354
		y	0.354	0.369	0.380	0.364
8L	8La	x	0.345	0.354	0.355	0.346
		y	0.352	0.364	0.375	0.362
	8Lb	x	0.346	0.355	0.356	0.347
		y	0.362	0.375	0.385	0.371
	8Lc	x	0.354	0.364	0.366	0.355
		y	0.364	0.380	0.391	0.375
	8Ld	x	0.355	0.366	0.367	0.356
		y	0.375	0.391	0.401	0.385

Tolerance ± 0.01 .

Color Coordinates Chart

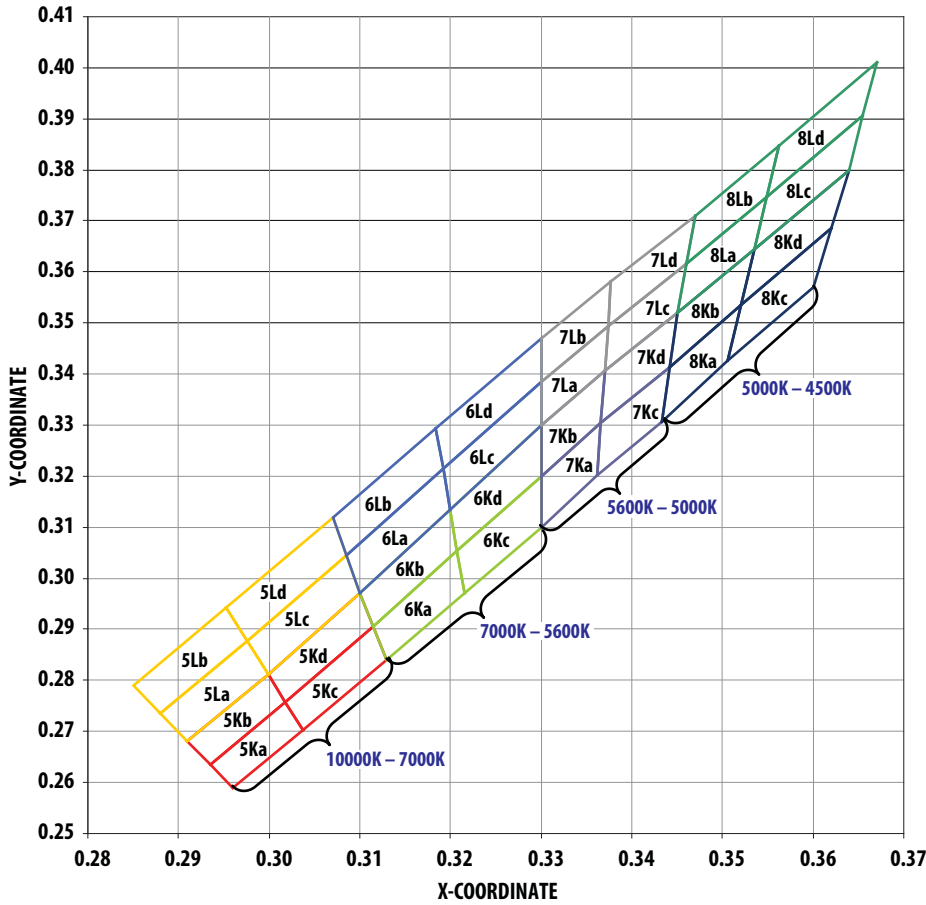

Vf Bin

Bin	Min. (V)	Max. (V)
S4	2.90	3.20
S5	3.20	3.50

Tolerance $\pm 0.1V$.

Packaging Option (X₅)

Option	Test Current	Package Type	Reel Size
E	150 mA	Top Mount	7 inch

Disclaimer

Broadcom's products and software are not specifically designed, manufactured, or authorized for sale as parts, components, or assemblies for the planning, construction, maintenance, or direct operation of a nuclear facility or for use in medical devices or applications. The customer is solely responsible, and waives all rights to make claims against Broadcom or its suppliers, for all loss, damage, expense, or liability in connection with such use.

Broadcom, the pulse logo, Connecting everything, Avago Technologies, Avago, and the A logo are among the trademarks of Broadcom and/or its affiliates in the United States, certain other countries, and/or the EU.

Copyright © 2012–2018 Broadcom. All Rights Reserved.

The term "Broadcom" refers to Broadcom Inc. and/or its subsidiaries. For more information, please visit www.broadcom.com.

Broadcom reserves the right to make changes without further notice to any products or data herein to improve reliability, function, or design. Information furnished by Broadcom is believed to be accurate and reliable. However, Broadcom does not assume any liability arising out of the application or use of this information, nor the application or use of any product or circuit described herein, neither does it convey any license under its patent rights nor the rights of others.

