

EFH.620 | Fold-away handles

Technopolymer



MATERIAL

Polyamide based (PA) technopolymer handle, black colour, matte finish.

STANDARD EXECUTIONS

- **EFH.620:** black-oxide steel pin, sintered and oxidised steel flat base for embedded mounting, black-oxide steel screw.
- **EFH.620-SST:** AISI 303 stainless steel pin, sintered AISI 303 stainless steel flat base for embedded mounting, AISI 303 stainless steel screw.

FEATURES AND APPLICATIONS

Handle pivots freely during operation: a system of coaxial bushings compensates return spring load.

This series of fold-away handles has been designed for all those applications for which, owing to lack of space or for safety reasons, the handle must be folded-away once the operation has been completed.



Normal assembly example with embedded base

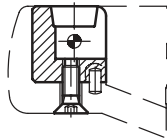

ERGOSTYLE® ELESA Original design

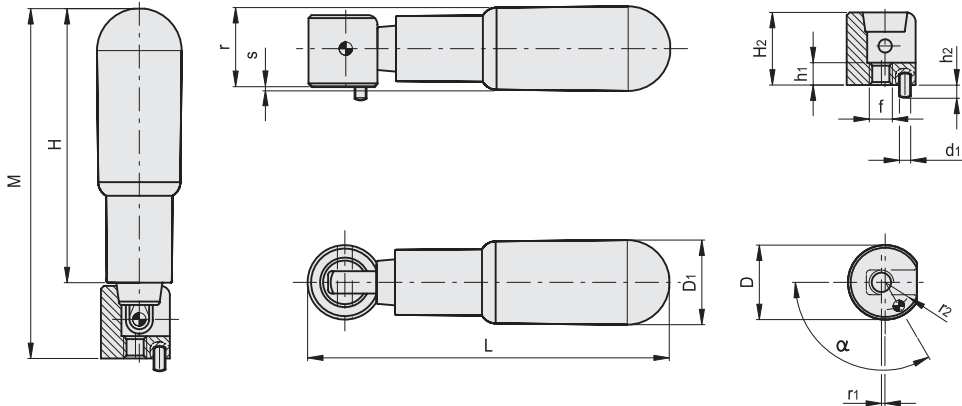

Conversion Table	
1 mm = 0.039 inch	
H	
mm	inch
60	2.36
65	2.56
80	3.15
90	3.54

EFH.620

METRIC

Code	Description	H	D	L	M	D1	H2	r	r1	s	f	h1	d1	h2-0.2	r2	α	△
285151-R	EFH.620/60 S.D.16	60	16	78	76	18	15	17.5	1	1	M4	5	3	3	5.5	90°	38
285161-R	EFH.620/65 S.D.16	65	16	83.5	81	22	15	19.5	1	2	M4	5	3	3	5.5	90°	75
285166-R	EFH.620/65 S.D.20	65	20	90.5	86	22	19.5	21.5	0.6	0.5	M6	6	3	3	7	120°	110
285171-R	EFH.620/80 S.D.20	80	20	105	101	24	19.5	22.5	0.6	1.5	M6	6	3	3	7	120°	120
285181-R	EFH.620/90 S.D.20	90	20	115	111	25	19.5	23	0.6	2	M6	6	3	3	7	120°	136

EFH.620-SST

INOX STAINLESS STEEL

METRIC

Code	Description	H	D	L	M	D1	H2	r	r1	s	f	h1	d1	h2-0.2	r2	α	△
285153-R	EFH.620/60-SST-S.D.16	60	16	78	76	18	15	17.5	1	1	M4	5	3	3	5.5	90°	38
285163-R	EFH.620/65-SST-S.D.16	65	16	83.5	81	22	15	19.5	1	2	M4	5	3	3	5.5	90°	75
285168-R	EFH.620/65-SST-S.D.20	65	20	90.5	86	22	19.5	21.5	0.6	0.5	M6	6	3	3	7	120°	110
285173-R	EFH.620/80-SST-S.D.20	80	20	105	101	24	19.5	22.5	0.6	1.5	M6	6	3	3	7	120°	120
285183-R	EFH.620/90-SST-S.D.20	90	20	115	111	25	19.5	23	0.6	2	M6	6	3	3	7	120°	136

