

PART NAME: KNOB SCALE: 1:1 DATE: 9/2/97 DR. BY HD

DAVIES MOLDING COMPANY  
CAROL STREAM, ILLINOIS 60188

P/N 1208AY	
BASE PART	1208-02
S.SCREW	I0022
CAP INLAY	I0789(SL)

THIS DRAWING IS THE PROPERTY OF DAVIES MOLDING COMPANY, IS SUBMITTED SOLELY AS A DESIGN OR ENGINEERING PROJECT. WE ACCEPT NO RESPONSIBILITY WHATSOEVER FOR THE PRACTICAL APPLICATION OF THE PIECES MADE TO THIS DESIGN.

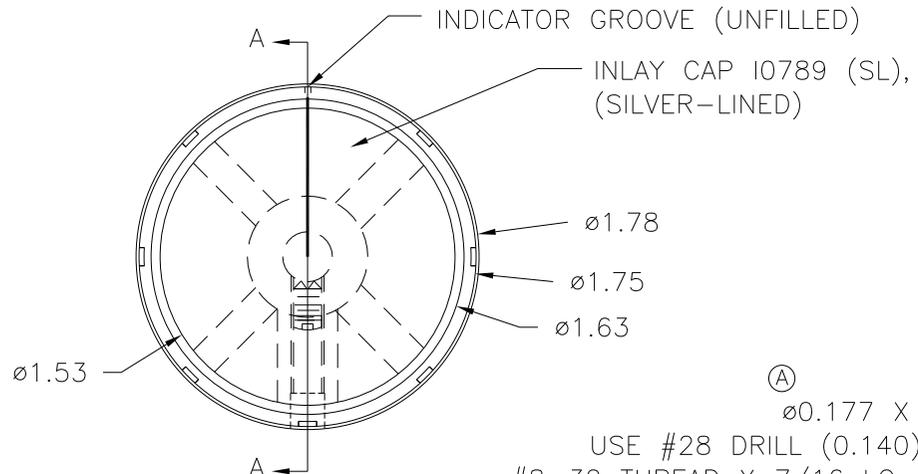

Ⓐ  
ø0.177 X 3/16 CBORE,  
USE #28 DRILL (0.140), #8-32 TAP,  
#8-32 THREAD X 7/16 LG. CUP POINTED,  
SLOTTED TYPE, SET SCREW I0022

SECTION A-A

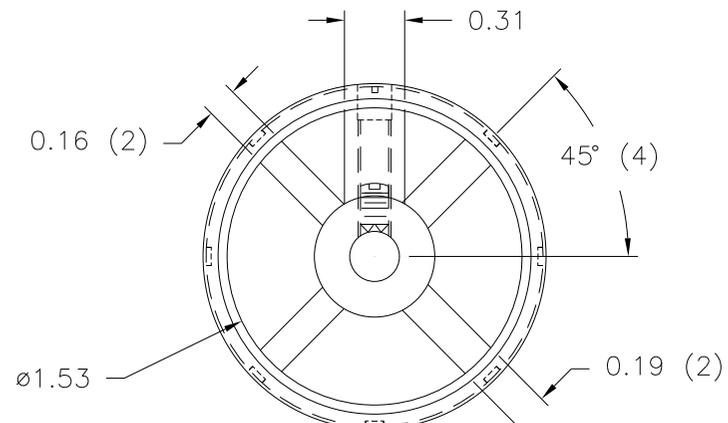
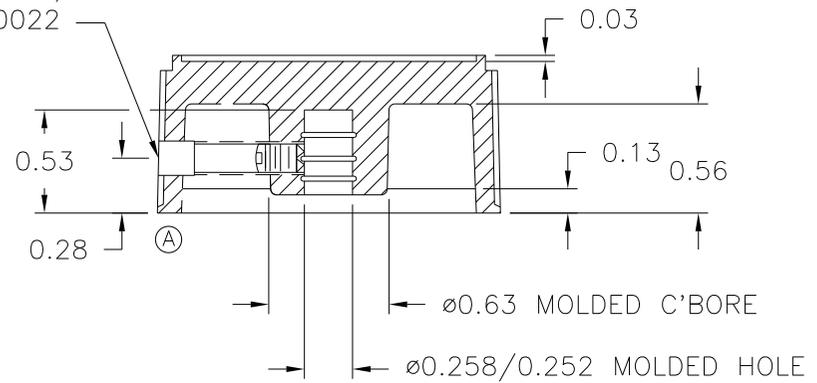
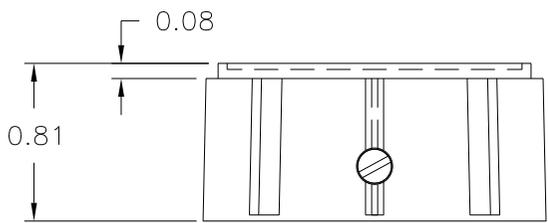

MATERIAL: G.P. PHENOLIC (B11)  
COLOR: BLACK

TOLERANCES: UNLESS OTHERWISE SPECIFIED	DO NOT SCALE DRAWING			
DECIMALS: X.XXX ± .005 X.XX ± .015	MM: X.XX ± 0.15MM X.X ± 0.4MM	A	ADDED CBORE, REDRAWN INCORRECTLY	JAM 1/11/02
		-	UPDATED/HAD TOOLBOX	ST 4/11/2000
FRACTIONS ± 1/64	ANG. ± 1°	CHANGES		