

Board Level Cooling – Space Saving 5925



BOARD LEVEL COOLING – Space Saving 5925

Space Saving 5925 is a series of staggered fin board level heat sinks designed to cool TO-220 and TO-220-single gauge devices. Representative image only.

ORDERING INFORMATION

Part Number	Device Type
592502B02800G	TO-220, TO-220-single gauge
592502B03400G	TO-220, TO-220-single gauge



HEAT SINK DETAILS

Property	Details
Material	Aluminum
Finish	Black Anodize
Device Attachment Options	Requires Mounting Kit
Thermal Interface Material	-

Property	Details
Heat Sink Width (mm)	6.35
Heat Sink Length (mm)	31.75
Heat Sink Height (mm)	22.22
Heat Sink Mounting Direction	Vertical

MECHANICAL & PERFORMANCE

Drawing dimensions are shown in mm, (in)

Part Number	"X" Dim	"Y" Dim	"Z" Dim
592502B02800G	7.62 (0.300)	2.45 (0.096)	2.39 (0.094)
592502B03400G	7.62 (0.350)	1.14 (0.045)	2.39 (0.094)

Part Number: 592502B02800G

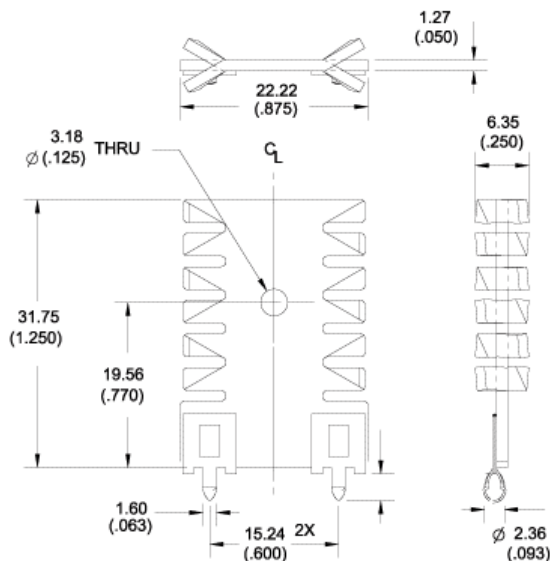

Mounting Details:

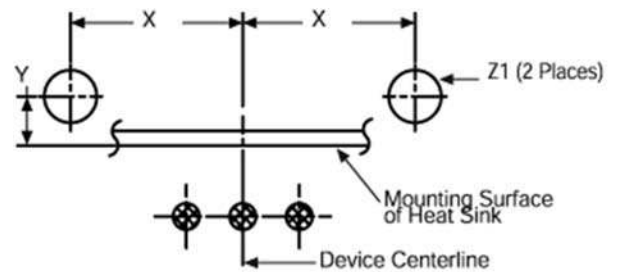

Board Level Cooling – Space Saving 5925

Part Number: 592502B03400G

