

THIS DRAWING IS UNPUBLISHED. RELEASED FOR PUBLICATION
 © COPYRIGHT - By - ALL RIGHTS RESERVED.

LOC	DIST	REVISIONS					
CM	00	P	LTR	DESCRIPTION	DATE	DWN	APVD
		R6		REVISED PER ECO-12-014997	22AUG12	KH	SM

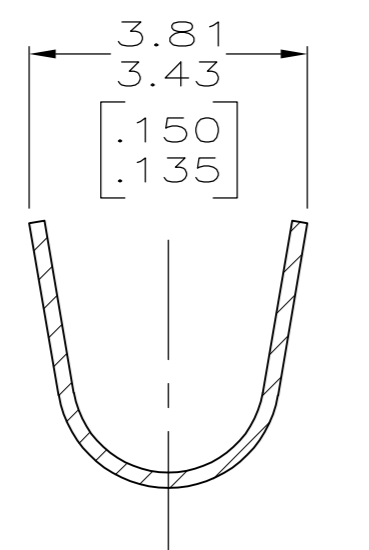

SECTION C-C

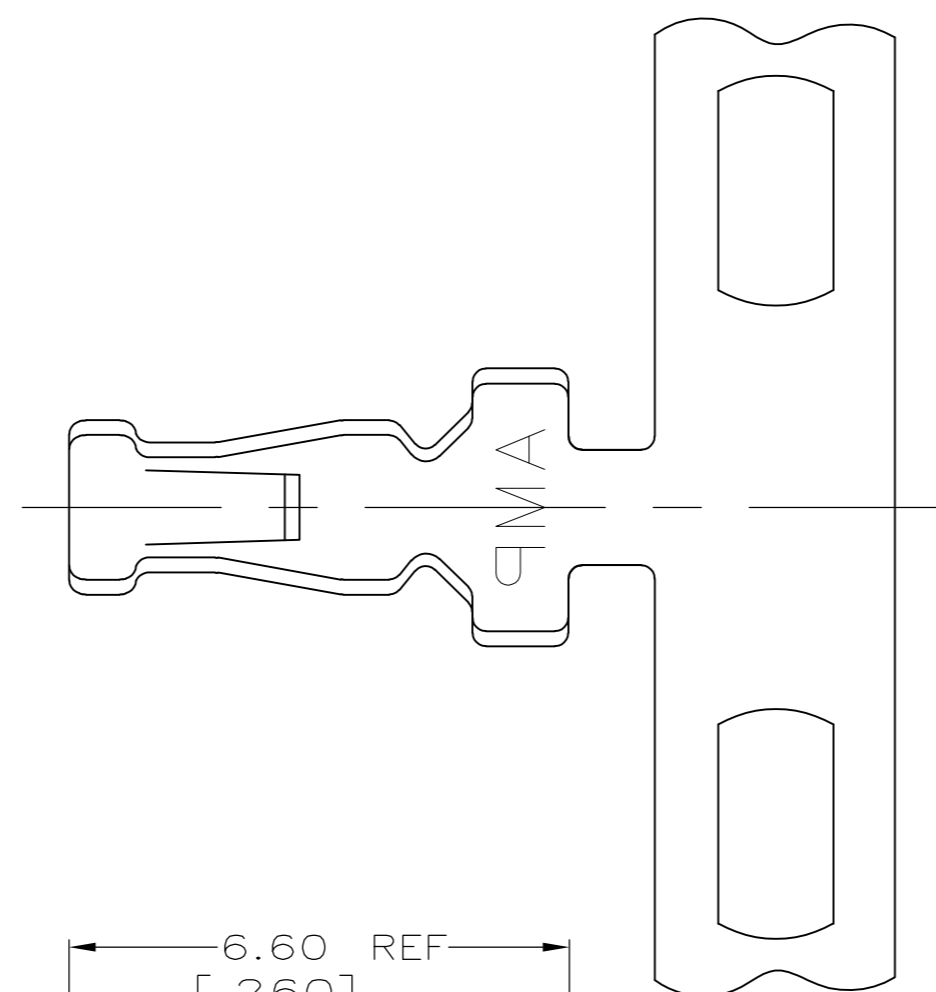
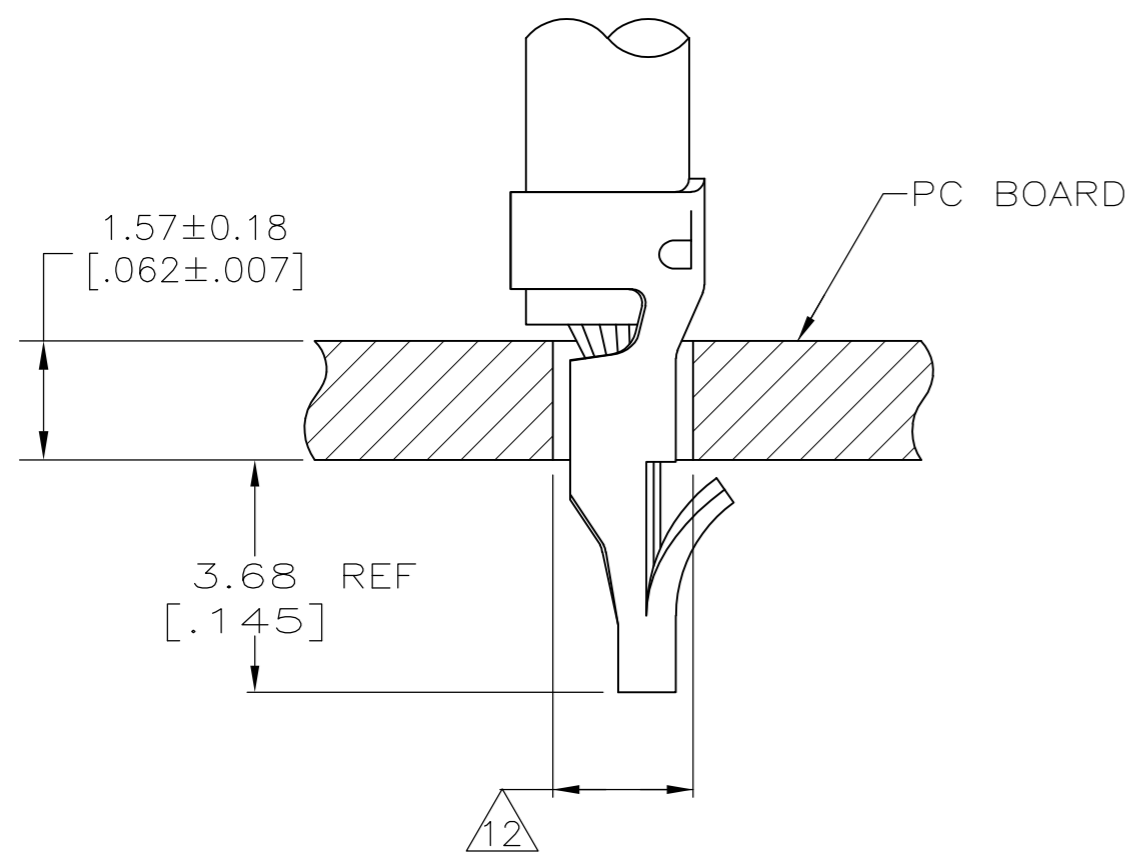
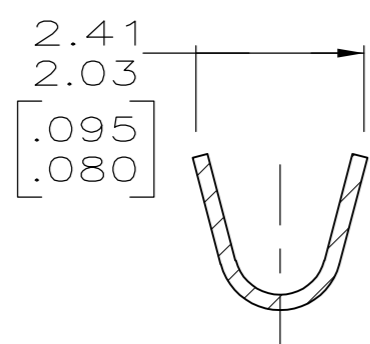
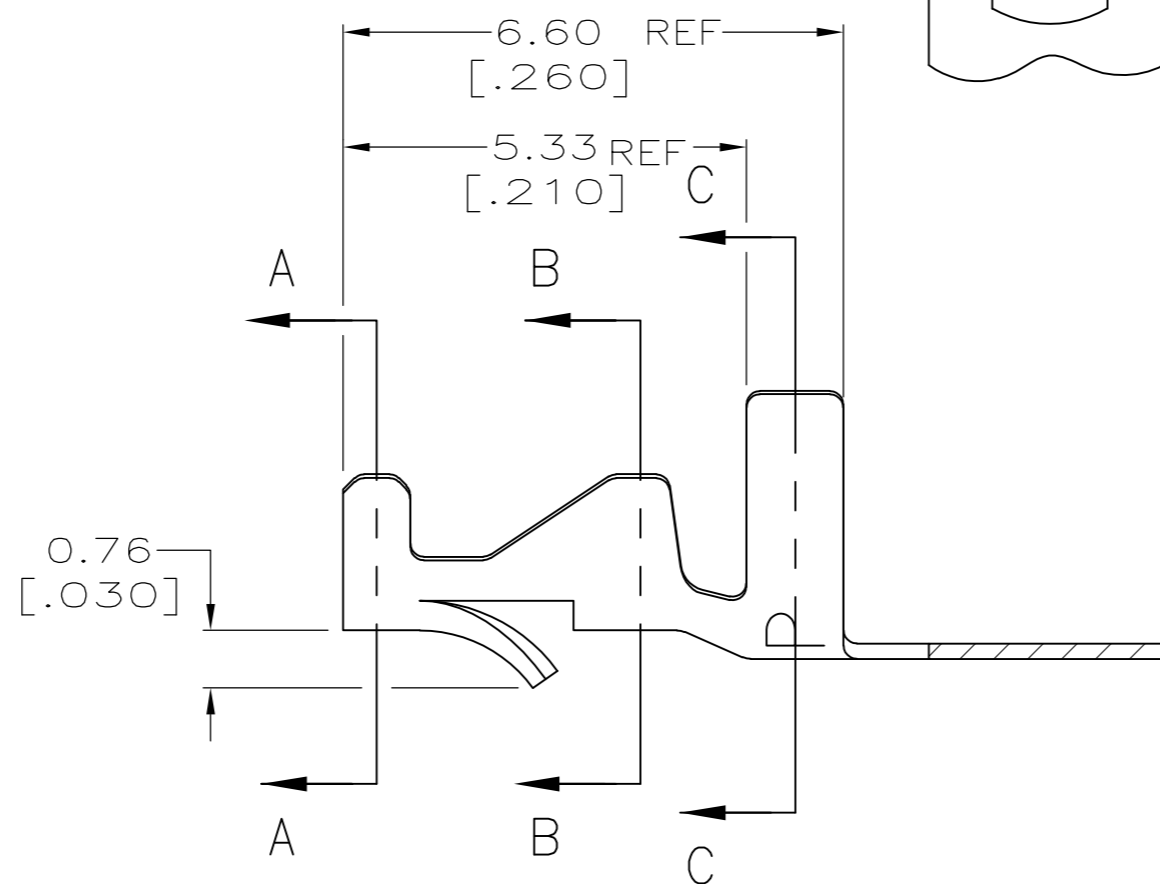

SECTION A-A, B-B

- 1 PARTS COMPLY WITH AMP SOLDERABILITY SPEC 109-11-3.
- 2 0.00508 [.000200] MIN BRIGHT TIN-LEAD.
- 3 PARTS COMPLY WITH AMP SOLDERABILITY SPEC 109-11-1.
- 4 0.00305 [.000120] MIN BRIGHT TIN-LEAD OVER 0.00102 [.000040] MIN NICKEL.
- 5 FOR FOREIGN PRODUCTION ONLY.
- 6 CARRIER STRIP TO HAVE 1.52 [.060] DIA PILOT HOLE
- 7 0.00305 [.000120] MIN TIN OVER 0.00102 [.000040] MIN NICKEL.
- 8 WIRE RANGE: 0.3 - 0.9 mm² (22 - 18 AWG).
- 9 INSULATION RANGE: 1.52 - 2.79 [.060 - .110] DIA.
- 10 DIMENSIONS IN BRACKETS ARE IN INCHES.
- 11 0.00508 [.000200] MIN BRIGHT TIN.
- 12 HOLE DIAMETER TO BE 1.83±0.08 FOR WIRE 0.3-0.6mm² (20-22 AWG) OR 1.96±0.08 FOR WIRE 0.8-0.9mm² (18 AWG).

NOTES	FINISH	MATERIAL	PART NO.
	1	0.20[.008] PH BRZ	3-640311-1
	11	0.20[.008] BRASS	640311-5
OBSOLETE	3 5 6	0.20[.008] BRASS	640311-3
SUPERSEDED BY 3-640311-1	3 5	0.20[.008] PH BRZ	640311-1
	1		
	2		

THIS DRAWING IS A CONTROLLED DOCUMENT.		DWN S. CARPENTER 21AUG2003	TE Connectivity	
DIMENSIONS: INCHES		CHK J. ELLIS 21AUG2003	NAME MINI AMP-IN™	
TOLERANCES UNLESS OTHERWISE SPECIFIED:		APVD J. ELLIS 21AUG2003	SIZE A2	
0 PLC ±		PRODUCT SPEC	CAGE CODE 00779	DRAWING NO 640311
1 PLC ±		APPLICATION SPEC	RESTRICTED TO	
2 PLC ± 0.13 [.005]		114-1016	SCALE 1:1	SHEET 1 of 1
3 PLC ±		WEIGHT	REV R6	
4 PLC ±		CUSTOMER DRAWING		
ANGLES ±				
FINISH				
SEE TABLE				

