

Power Supply IC Series for TFT-LCD Panels

Single-channel Source Voltage Output Power Supply + Gamma Buffer Amp ICs



BD8151EFV, BD8157EFV

No.09035EBT11

●Description

The BD8151EFV, BD8157EFV power supply IC are designed for use with TFT-LCD panels. It incorporates a built-in source voltage step-up switching regulator and gamma correction buffer amp. The combination of a source power supply and gamma correction buffer on a single chip delivers significant cost savings. Compatible with input voltages from 2.5 V to 5.5 V (BD8151EFV), 2.1 V to 4.0 V (BD8157EFV), the IC supports low-voltage operation and reaches over 85% efficiency with a 2.5 V input, contributing to low power consumption designs.

●Features

- 1) Single-chip implementation of a source power supply and gamma correction buffer
- 2) Support for low-voltage operation, with input voltages from 2.5 V to 5.5 V (BD8151EFV)
2.1 V to 4.0 V (BD8157EFV)
- 3) Built-in 1.4 A, 0.2 Ω low-voltage FET
- 4) Switchable step-up DC/DC switching frequencies: 600 kHz/1.2 MHz
- 5) Current mode PWM control
- 6) Under-voltage lockout protection circuit
- 7) Built-in overcurrent protection circuit
- 8) Built-in thermal shutdown circuit

●Applications

Satellite navigation systems, laptop PC TFT LCD panels
LCD monitor panels

●Absolute maximum ratings (Ta = 25°C)

Parameter	Symbol	Limit	Unit
Power supply voltage	Vcc	7	V
Power dissipation	Pd	1000*	mW
Operating temperature range	BD8151EFV	-40 to +85	°C
	BD8157EFV	-40 to +125	
Storage temperature range	Tstg	-55 to +150	°C
Switching pin current	Isw	1.5**	A
Switching pin voltage	Vsw	15	V
VS voltage	VS	15	V
Maximum junction temperature	Tjmax	150	°C

* Reduced by 8 mW/°C over 25°C, when mounted on a glass epoxy board (70 mm x 70 mm x 1.6 mm).

** Must not exceed Pd.

●Recommended Operating Ranges (Ta = 25°C)

Parameter	Symbol	Limit			Unit
		Min.	Typ.	Max.	
Power supply voltage BD8151EFV	Vcc	2.5	3.3	5.5	V
Power supply voltage BD8157EFV	Vcc	2.1	2.5	4.0	V
Switching current	ISW	—	—	1.4	A
Switching pin voltage	VSW	—	—	14	V
VS pin voltage	VS	5	9	14	V

● Electrical Characteristics BD8151EFV (Unless otherwise specified, Ta = 25°C; Vcc = 3.3V, ENB = 3.3V)

Parameter	Symbol	Limit			Unit	Conditions
		Min.	Typ.	Max.		
[Triangular waveform oscillator]						
Oscillating frequency 1	FOSC1	540	600	660	kHz	FCLK = 0 V
Oscillating frequency 2	FOSC2	1.08	1.20	1.32	MHz	FCLK = Vcc
[Overcurrent protection circuit]						
Overcurrent limit	ISW	—	2	—	A	
[Soft start circuit]						
SS source current	ISO	6	10	14	μA	Vss = 0.5 V
[Under-voltage lockout protection circuit]						
Off threshold voltage	VUTOFF	2.1	2.2	2.3	V	
On threshold voltage	VUTON	2.0	2.1	2.2	V	
[Error amp]						
Input bias current	IB	—	0.1	0.5	μA	
Feedback voltage	VFB	1.232	1.245	1.258	V	Buffer
[Output]						
On resistance	RON	—	200	300	mΩ	*Isw = 1 A
Max. duty ratio	DMAX	72	80	88	%	RL = 100 Ω
[ENB]						
ENB on voltage	VON	Vcc × 0.7	Vcc	—	V	
ENB off voltage	VOFF	—	0	Vcc × 0.3	V	
[Overall]						
Standby current	ISTB	—	0	10	μA	VENB = 0 V
Average consumption current	ICC	—	1.2	2.4	mA	no switching
[Amp]						
Input bias current	Ibo	-1	0	1	μA	IN += 4.5 V
Drive current 1	IOO1	50	70	140	mA	OUT1 to OUT4
Drive current 2	IOO2	150	200	400	mA	VCOM
Max. output current	Vo _{ho}	VS-0.16	VS-0.1	—	V	I _o = -5 mA, IN += VS
Min. output current	Vo _{hl}	—	0.1	0.16	V	I _o = 5 mA, IN += 0 V

○ This product is not designed for protection against radio active rays.

* Design guarantee (No total shipment inspection is made.)

●Electrical Characteristics BD8157EFV (Unless otherwise specified, Ta = 25°C; Vcc = 2.5V, ENB = 2.5V)

Parameter	Symbol	Limit			Unit	Conditions
		Min.	Typ.	Max.		
[Triangular waveform oscillator]						
Oscillating frequency 1	FOSC1	480	600	720	kHz	FCLK = 0 V
Oscillating frequency 2	FOSC2	0.96	1.20	1.44	MHz	FCLK = Vcc
[Overcurrent protection circuit]						
Overcurrent limit	ISW	—	2	—	A	
[Soft start circuit]						
SS source current	ISO	6	10	14	μA	Vss = 0.5 V
[Under-voltage lockout protection circuit]						
Off threshold voltage	VUTOFF	1.7	1.8	1.9	V	
On threshold voltage	VUTON	1.6	1.7	1.8	V	
[Error amp]						
Input bias current	IB	—	0.1	0.5	μA	
Feedback voltage	VFB	1.232	1.245	1.258	V	Buffer
[Output]						
On resistance	RON	—	200	600	mΩ	*Isw = 1 A
Max. duty ratio	DMAX	75	85	95	%	RL = 100 Ω
[ENB]						
ENB on voltage	VON	Vcc × 0.7	Vcc	—	V	
ENB off voltage	VOFF	—	0	Vcc × 0.3	V	
[Overall]						
Standby current	ISTB	—	0	10	μA	VENB = 0 V
Average consumption current	ICC	—	1.2	2.4	mA	no switching
[Amp]						
Input bias current	Ibo	-1	0	1	μA	IN += 4.5 V
Drive current 1	IOO1	50	70	140	mA	OUT1 to OUT4
Drive current 2	IOO2	120	200	400	mA	VCOM
Max. output current	VoHo	VS-0.16	VS-0.1	—	V	Io = -5 mA, IN += VS
Min. output current	VoHl	—	0.1	0.16	V	Io = 5 mA, IN += 0 V

○ This product is not designed for protection against radio active rays.

* Design guarantee (No total shipment inspection is made.)

●Reference Data (Unless otherwise specified, Ta = 25°C)

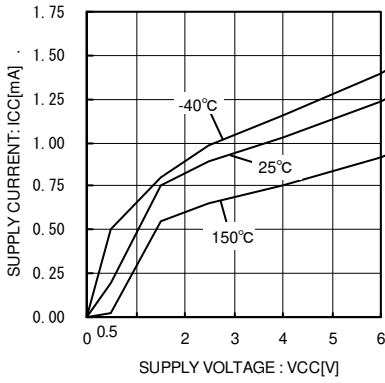

Fig. 1 Total Supply Current

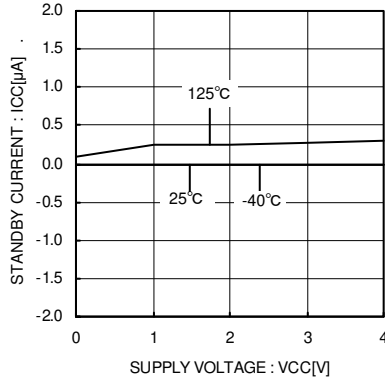

Fig. 2 Standby Current

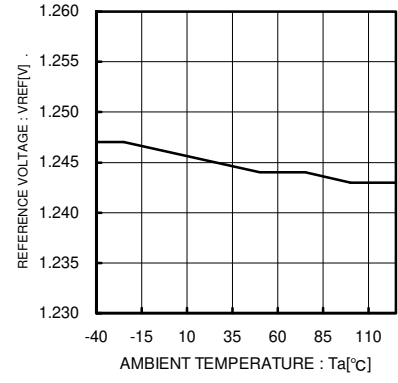

Fig. 3 Reference Voltage Temperature

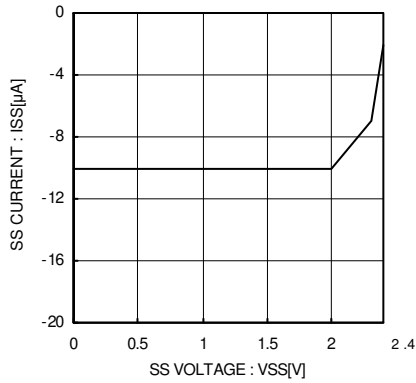

Fig. 4 SS Source Current

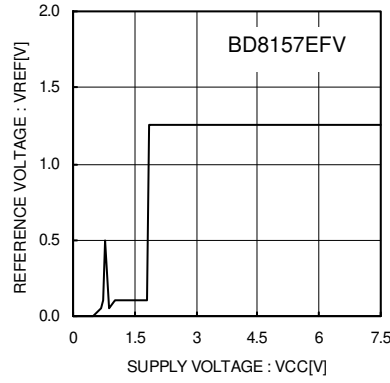

Fig. 5 Reference Voltage Temperature

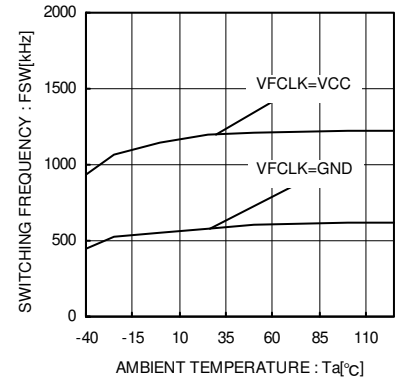

Fig. 6 Switching Frequency Temperature

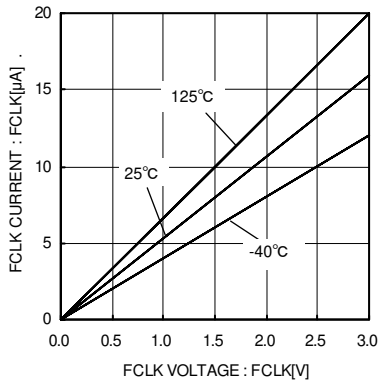

Fig. 7 FCLK Pin Current

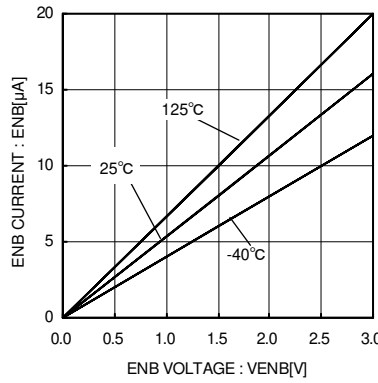

Fig. 8 ENB Pin Current

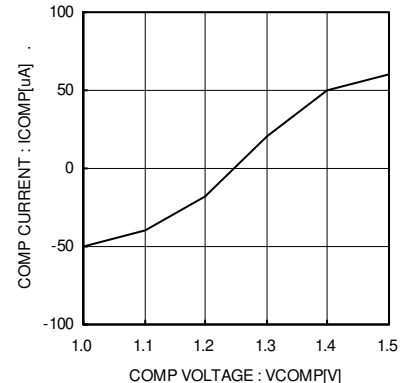

Fig. 9 COMP Sinking vs Source Current

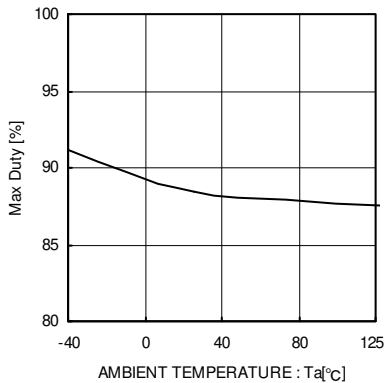

Fig. 10 Max. Duty Ratio Temperature

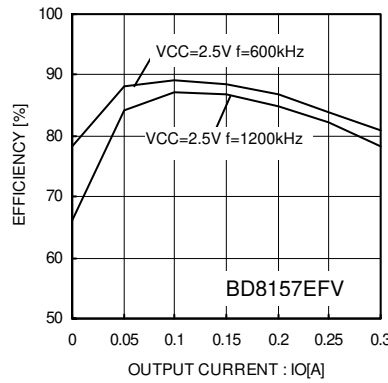

Fig. 11 Vcc = 2.5 V Power Efficiency

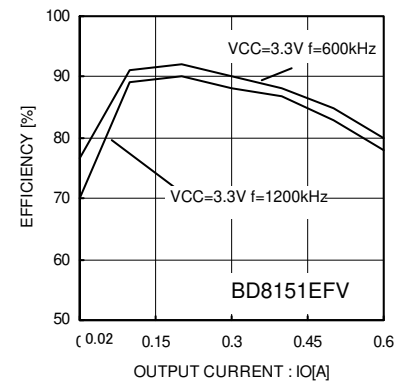

Fig. 12 Vcc = 3.3 V Power Efficiency

●Reference Data (Unless otherwise specified, Ta = 25°C)

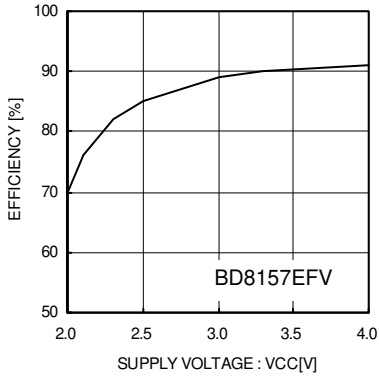

Fig. 13 Power Efficiency vs Power Supply Voltage

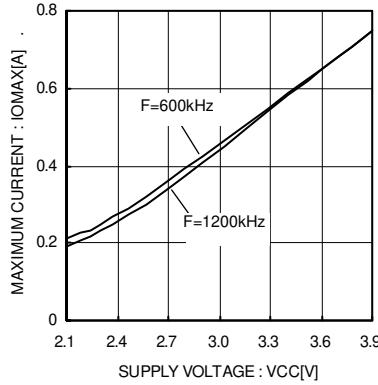

Fig. 14 Max. Load Current vs Power Supply Voltage

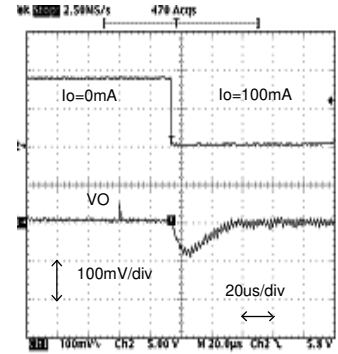

Fig. 15 Load Response Waveform

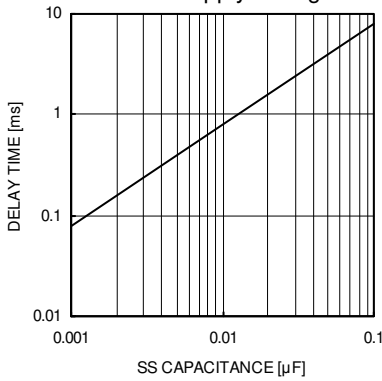

Fig. 16 SS Capacitance vs Delay Time

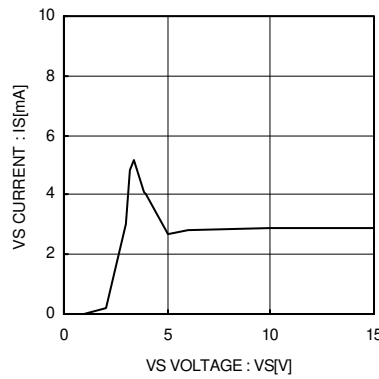

Fig. 17 VS Pin Current

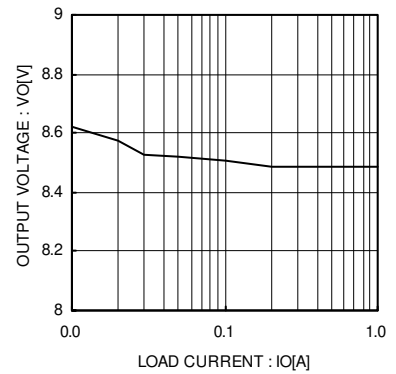

Fig. 18 Output voltage Load Regulation 1

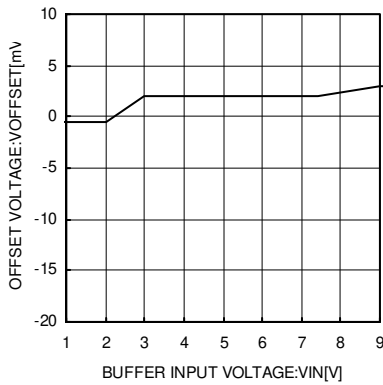

Fig. 19 Buffer Voltage

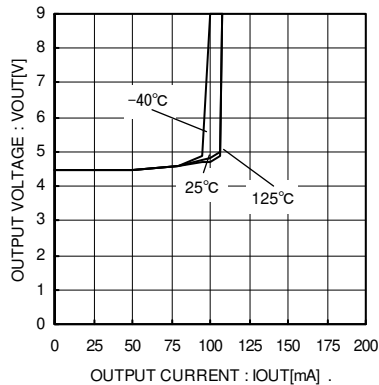

Fig. 20 Buffer Sinking Current

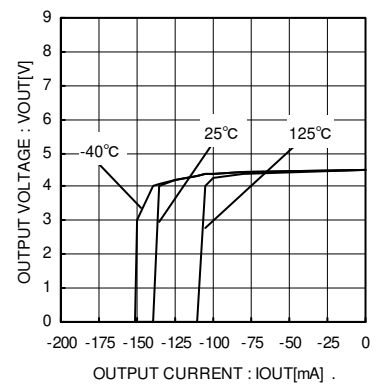

Fig. 21 Buffer Source Current

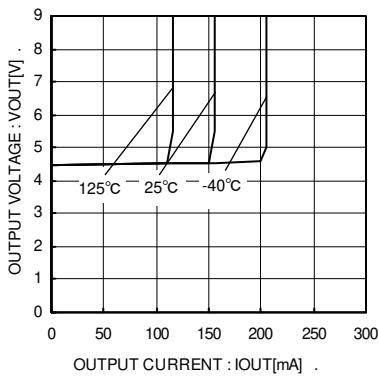

Fig. 22 VCOM Sinking Current

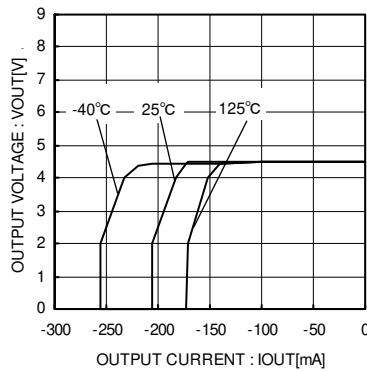

Fig. 23 VCOM Source Current

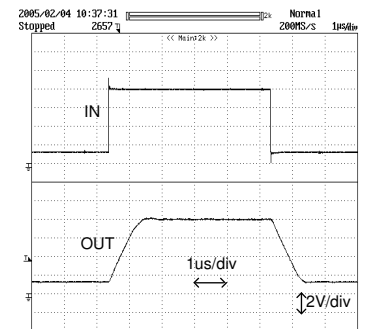
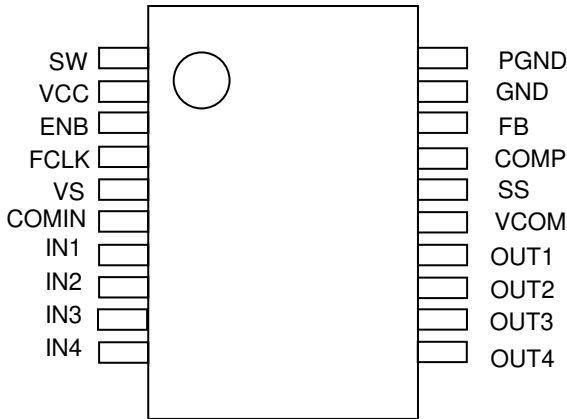

Fig. 24 Slew Rate Waveform

● Pin Assignment Diagram



● Block Diagram

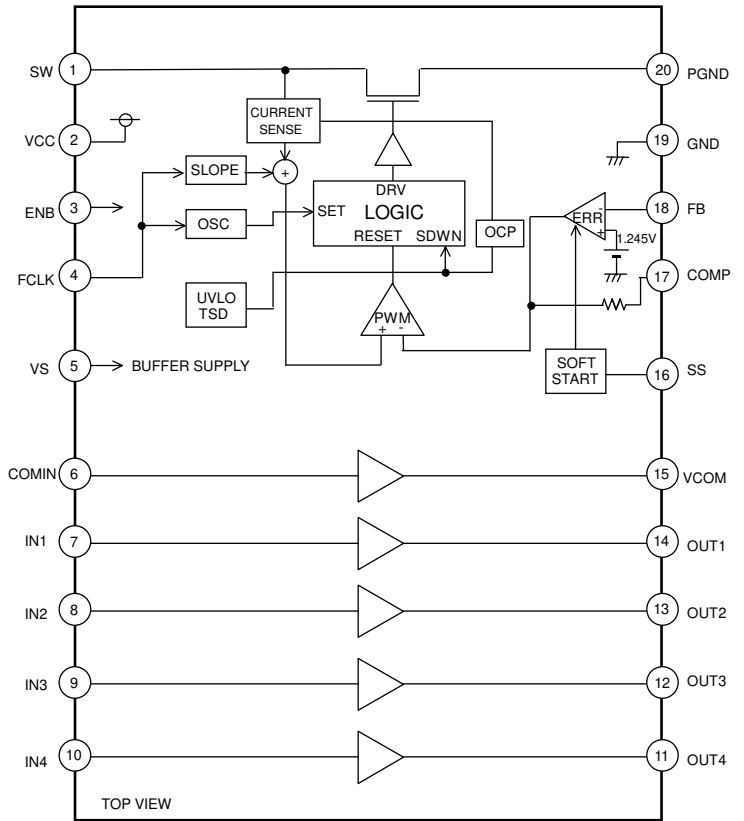

Fig. 25 Pin Assignment Diagram and Block Diagram

● Pin Assignment Diagram and Pin Functions

Pin No.	Pin name	Function
1	SW	N-channel power FET drain output
2	VCC	Power supply input pin
3	ENB	Control input pin
4	FCLK	Frequency switching pin
5	VS	Buffer power supply input pin
6	COMIN	VCOM input pin
7	IN1	Amp input pin 1
8	IN2	Amp input pin 2
9	IN3	Amp input pin 3
10	IN4	Amp input pin 4
11	OUT4	Amp output pin 4
12	OUT3	Amp output pin 3
13	OUT2	Amp output pin 2
14	OUT1	Amp output pin 1
15	VCOM	VCOM output pin
16	SS	Soft start current output pin
17	COMP	Error amp output pin
18	FB	Error amp inversion input pins
19	GND	Ground pin
20	PGND	Ground pin

●Description of Operation of Each Block

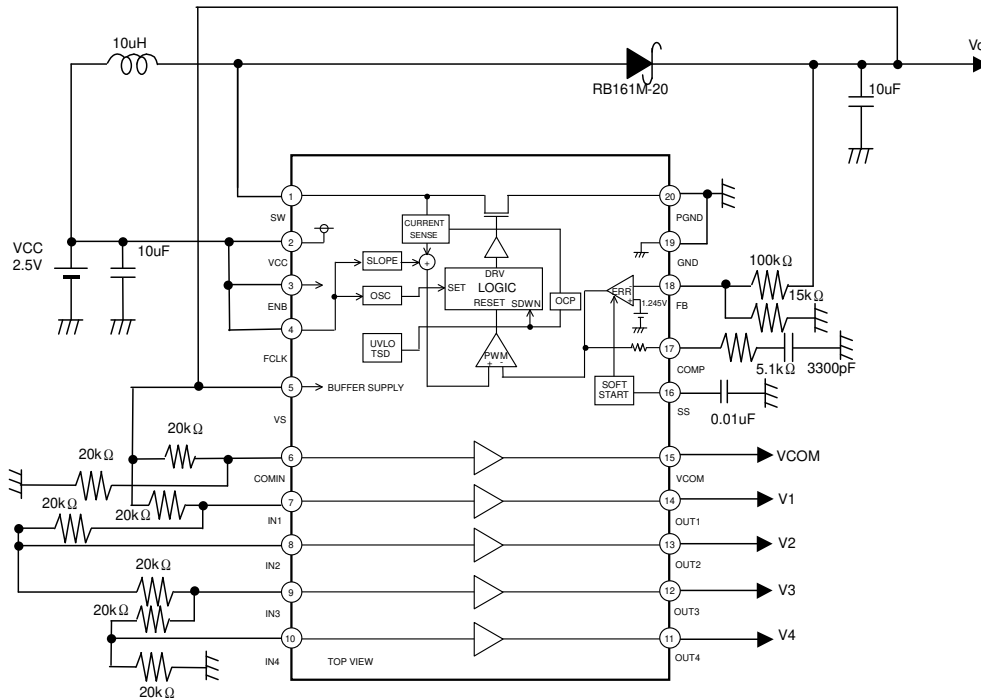

Fig. 26 Application Circuit Diagram

- Error amp (ERR)**
 This is the circuit to compare the reference voltage 1.245 V (Typ.) and the feedback voltage of output voltage. The COM pin voltage resulting from this comparison determines the switching duty. At the time of start, since the soft start is operated by the SS pin voltage, the COMP pin voltage is limited to the SS pin voltage.
- Oscillator (OSC)**
 This block generates the oscillating frequency. Either a 600 kHz or 1.2 MHz (Typ.) frequency can be selected with the FCLK pin.
- SLOPE**
 This block generates the triangular waveform from the clock generated by OSC. Generated triangular waveform is sent to the PWM comparator.
- PWM**
 The COMP pin voltage output by the error amp is compared to the SLOPE block's triangular waveform to determine the switching duty. Since the switching duty is limited by the maximum duty ratio which is decided internally, it does not become 100%.
- Reference voltage (VREF)**
 This block generates the internal reference voltage of 1.245 V (Typ.).
- Protection circuit (UVLO/TSD)**
 UVLO (under-voltage lockout protection circuit) shuts down the circuits when the voltages are 2.2 V (Typ. BD8151EFV) 1.8 V (Typ. ND8157EFV) or lower. Thermal shutdown circuit shuts down IC at 175°C (Typ.) and recovers at 160°C (Typ.).
- Overcurrent protection circuit (OCP)**
 Current flowing to the power FET is detected by voltage at the CURRENT SENSE and the overcurrent protection operates at 3 A (Typ.). When the overcurrent protection operates, switching is turned off and the SS pin capacity is discharged.
- Soft start circuit**
 Since the output voltage rises gradually while restricting the current at the time of startup, it is possible to prevent the output voltage overshoot or the inrush current.
- Buffer amp and VCOM**
 This buffer amp is used to set the gamma correction voltage, which can be set in from 0.2 V to (VOUT - 0.2 V). Use the VOUT resistance division to set the gamma correction voltage. The VCOM voltage is set similarly.

●Timing Chart

Startup sequence

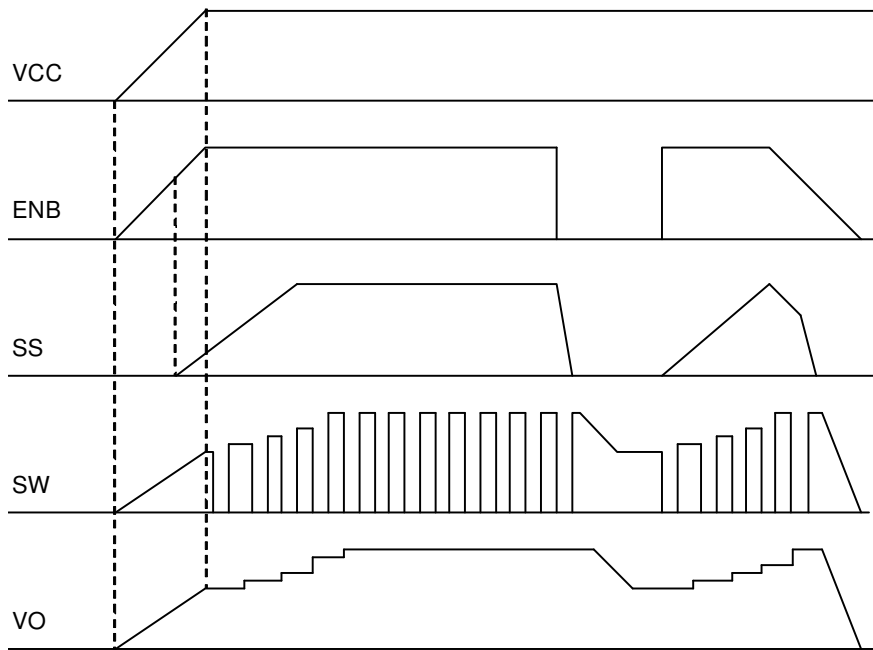

Fig. 27 Startup sequence

Overcurrent protection operating

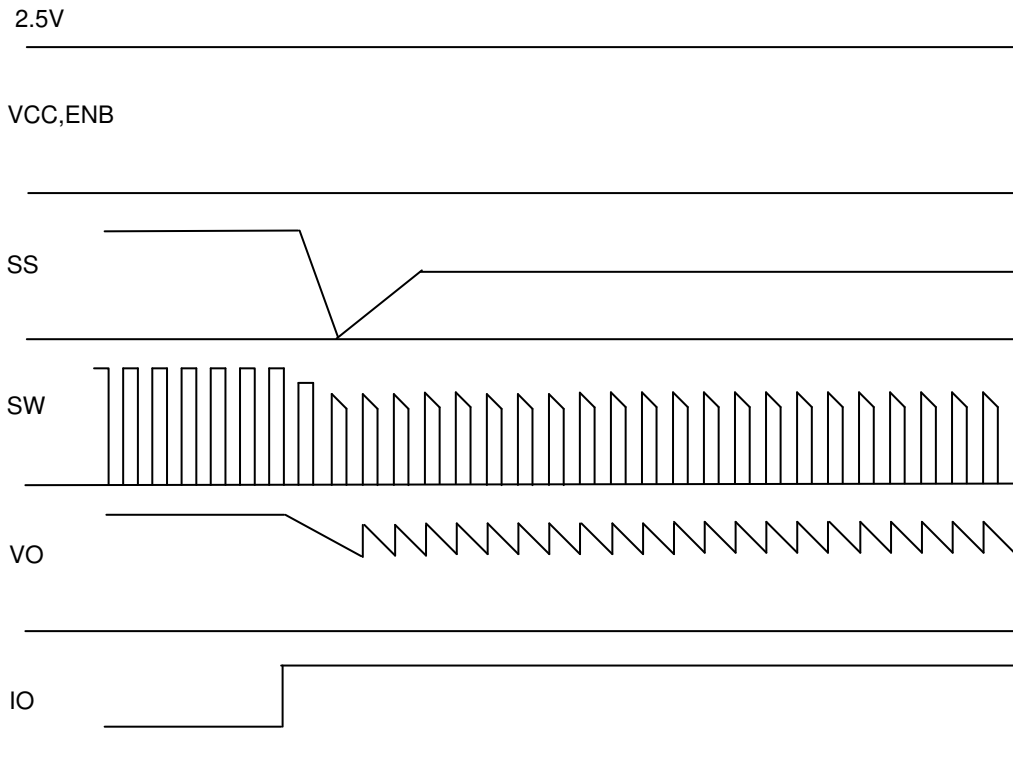

Fig. 28 Overcurrent protection operating

● Selecting Application Components

(1) Setting the output L constant

The coil L to use for output is decided by the rating current I_{LR} and input current maximum value I_{INMAX} of the coil.

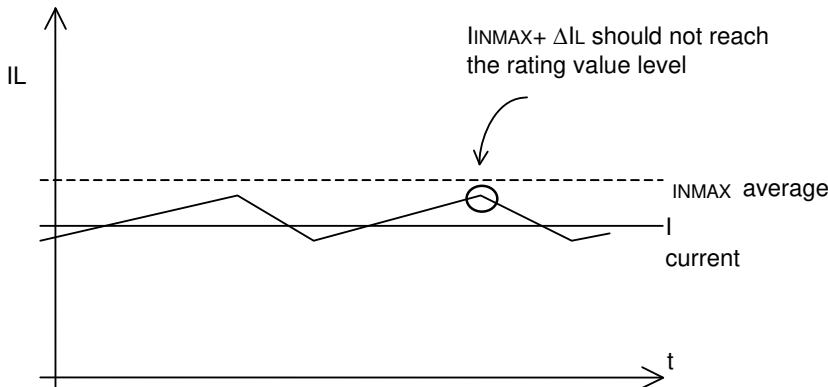

Fig. 29 Coil Current Waveform

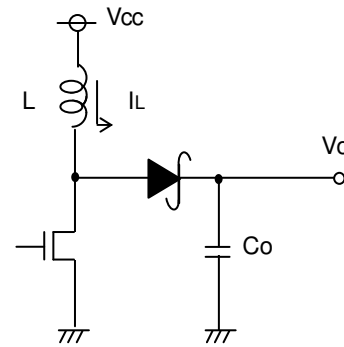

Fig. 30 Output Application Circuit Diagram

Adjust so that $I_{INMAX} + \Delta I_L$ does not reach the rating current value I_{LR} . At this time, ΔI_L can be obtained by the following equation.

$$\Delta I_L = \frac{1}{L} V_{CC} \times \frac{V_o - V_{CC}}{V_{CC}} \times \frac{1}{f} \text{ [A]} \quad \text{Where, } f \text{ is the switching frequency.}$$

Set with sufficient margin because the coil L value may have the dispersion of approx. $\pm 30\%$. If the coil current exceeds the rating current I_{LR} of the coil, it may damage the IC internal element.

BD8157EFV uses the current mode DC/DC converter control and has the optimized design at the coil value. The following coil values are recommended from the aspects of power efficiency, response and safety. When the coil out of this range is selected, the stable continual operation is not guaranteed such as the switching waveform becomes irregular. Please pay attention to it.

Switching frequency: L = 10 μH to 22 μH at 600 kHz

Switching frequency: L = 4.7 μH to 15 μH at 1,200 kHz

(2) Setting the output capacitor

For the capacitor C to use for the output, select the capacitor which has the larger value in the ripple voltage V_{PP} allowance value and the drop voltage allowance value at the time of sudden load change. Output ripple voltage is decided by the following equation.

$$\Delta V_{PP} = I_{LMAX} \times R_{ESR} + \frac{1}{f C_o} \times \frac{V_{CC}}{V_o} \times \left(I_{LMAX} - \frac{\Delta I_L}{2} \right) \text{ [V]} \quad \text{Where, } f \text{ is the switching frequency.}$$

Perform setting so that the voltage is within the allowable ripple voltage range.

For the drop voltage during sudden load change; V_{DR} , please perform the rough calculation by the following equation.

$$V_{DR} = \frac{\Delta I}{C_o} \times 10 \mu \text{ sec} \text{ [V]}$$

However, 10 μs is the rough calculation value of the DC/DC response speed. Please set the capacitance considering the sufficient margin so that these two values are within the standard value range.

(3) Selecting the input capacitor

Since the peak current flows between the input and output at the DC/DC converter, a capacitor is required to install at the input side. For this reason, the low ESR capacitor is recommended as an input capacitor which has the value more than 10 μF and less than 100 m Ω . If a capacitor out of this range is selected, the excessive ripple voltage is superposed on the input voltage, accordingly it may cause the malfunction of IC.

However these conditions may vary according to the load current, input voltage, output voltage, inductance and switching frequency. Be sure to perform the margin check using the actual product.

(4) Selecting the output rectification diode

Schottky barrier diode is recommended as the rectification diode to use at the DC/DC converter output stage. Select the diode paying attention to the max. inductor current and max. output voltage.

Max. inductor current $I_{INMAX} + \Delta I_L < \text{Rating current of diode}$

Max. output voltage $V_{OMAX} < \text{Rating voltage of diode}$

Since each parameter has 30% to 40% of dispersion, be sure to design providing sufficient margins.

(5) Design of the feedback resistor constant

Refer to the following equation to set the feedback resistor. As the setting range, 10 kΩ to 330 kΩ is recommended. If the resistor is set to a 10 kΩ or lower, it causes the reduction of power efficiency. If it is set to 330 kΩ or larger, the offset voltage becomes larger by the input bias current 0.4 μA (Typ.) in the internal error amplifier.

$$V_o = \frac{R8 + R9}{R9} \times 1.245 \text{ [V]}$$

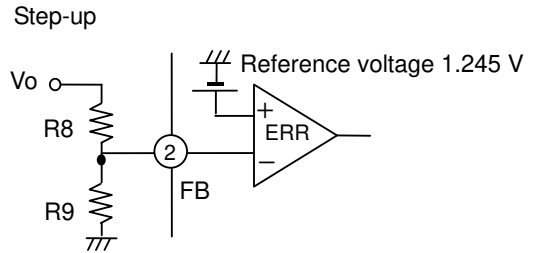

Fig. 31 Feedback Resistance Setting

(6) Setting the soft start time

Soft start is required to prevent the coil current at the time of startup from increasing and the overshoot of the output voltage at the starting time. Fig. 32 shows the relation between the capacitance and soft start time. Please refer to it to set the capacitance.

As the capacitance, 0.001 μF to 0.1 μF is recommended. If the capacitance is set to 0.001 μF, the overshooting may occur on the output voltage. If the capacitance is set to 0.1 μF or larger, the excessive back current flow may occur in the internal parasitic elements when the power is turned OFF and it may damage IC. When the capacitor of 0.1 μF or larger is used, be sure to insert a diode to Vcc in series, or a bypass diode between the SS pin and VCC.

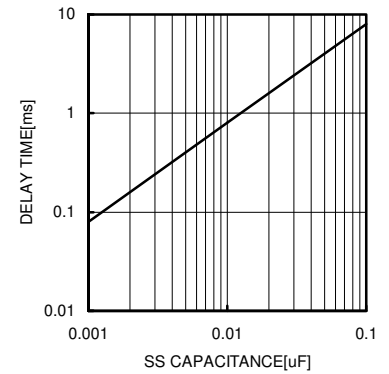

Fig.32 SS Pin Capacitance vs Delay Time

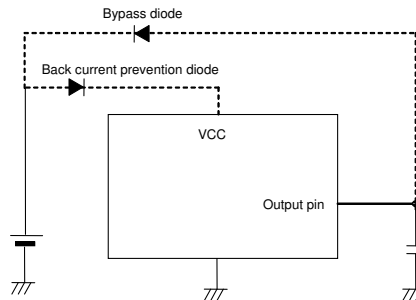

Fig. 33 Bypass Diode Example

When there is the startup relation (sequences) with other power supplies, be sure to use the high accuracy product (such as X5R). Soft start time may vary according to the input voltage, output voltage loads, coils and output capacity. Be sure to verify the operation using the actual product.

(7) Setting the ENB pin

When the ENB pin is set to Hi, the internal circuit becomes active and the DC/DC converter starts operating. When it is set to Low, the shut down is activated and all circuits will be turned OFF.

(8) Setting the frequency by FCLK

It is possible to change the switching frequency by setting the FCLK pin to Hi or Low. When it is set to Low, the product operates at 600 kHz (Typ.). When it is set to Hi, the product operates at 1,200 kHz (Typ.).

(9) Setting R_C , C_C of the phase compensation circuit

In the current mode control, since the coil current is controlled, a pole (phase lag) made by the CR filter composed of the output capacitor and load resistor will be created in the low frequency range, and a zero (phase lead) by the output capacitor and ESR of capacitor will be created in the high frequency range. In this case, to cancel the pole of the power amplifier, it is easy to compensate by adding the zero point with C_C and R_C to the output from the error amplifier as shown in the illustration.

Open loop gain

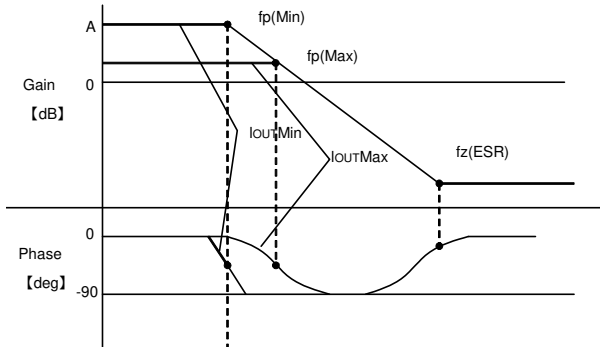

$$f_p = \frac{1}{2\pi \times R_o \times C_o} \quad [\text{Hz}]$$

$$f_z(\text{ESR}) = \frac{1}{2\pi \times \text{ESR} \times C_o} \quad [\text{Hz}]$$

Pole at the power amplification stage

When the output current reduces, the load resistance R_o increases and the pole frequency lowers.

$$f_p(\text{Min}) = \frac{1}{2\pi \times R_{o\text{Max}} \times C_o} \quad [\text{Hz}] \quad (\text{At light-load})$$

$$f_z(\text{Max}) = \frac{1}{2\pi \times R_{o\text{Min}} \times C_o} \quad [\text{Hz}] \quad (\text{At heavy-load})$$

Zero at the power amplification stage

When the output capacitor is set larger, the pole frequency lowers but the zero frequency will not change. (This is because the capacitor ESR becomes 1/2 when the capacitor becomes 2 times.)

$$f_p(\text{Amp.}) = \frac{1}{2\pi \times R_c \times C_c} \quad [\text{Hz}]$$

Error amplifier phase compensation

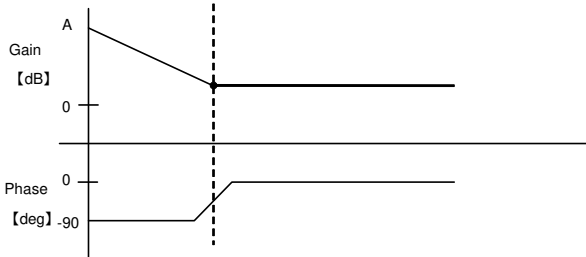

Fig. 34 Gain vs Phase

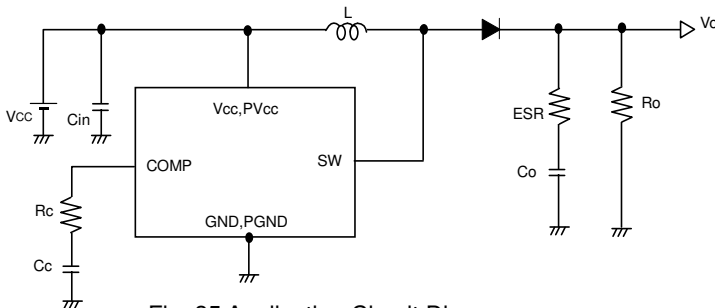

Fig. 35 Application Circuit Diagram

It is possible to realize the stable feedback loop by canceling the pole $f_p(\text{Min.})$, which is created by the output capacitor and load resistor, with CR zero compensation of the error amplifier as shown below.

$$f_z(\text{Amp.}) = f_p(\text{Min.})$$

$$\longrightarrow \frac{1}{2\pi \times R_c \times C_c} = \frac{1}{2\pi \times R_{o\text{max}} \times C_o} \quad [\text{Hz}]$$

As the setting range for the resistor, 1 kΩ to 10 kΩ is recommended. When the resistor is set to 1 kΩ or lower, the effect by phase compensation becomes low and it may cause the oscillation of output voltage. When it is set to 10 kΩ or larger, the COMP pin becomes Hi-Z and the switching noise becomes easy to superpose. Therefore the stable switching pulse cannot be generated and the irregular ripple voltage may be generated on the output voltage.

As the setting range for the capacitance, 3,300 pF to 10,000 pF is recommended. When the capacitance is set to 3,300 pF or lower, the irregular ripple voltage may be generated on the output voltage due to the effect of switching noise. When it is set to 10,000 pF or larger, the response becomes worse and the output voltage fluctuation becomes large. Accordingly it may require the output capacitor which is larger than the necessary value.

(10) Using the buffer amp and VCOM

The 4-channel buffer amp and 1-channel VCOM output are used to generate the gamma compensation voltage that is input to the source driver. The VS pin serves as the power supply for the buffer amp and VCOM.

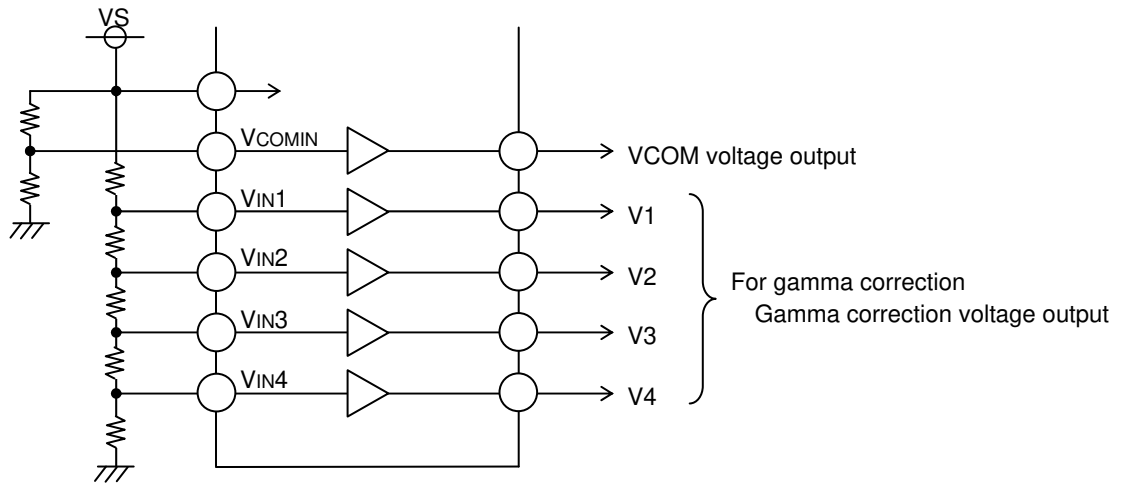

Fig. 36 Example Buffer Amp Circuit

Use caution as the gamma correction buffer amp and VCOM have different output current capacities. A range from I/O power supply to ground potentials can be set for the built-in buffer amplifier. If output voltage noise becomes problematic, insert a 0.1 μF capacitor in the output circuit. A capacitance value of 0 pF to 1 μF is recommended for this capacitor. Large capacitance values of 1 μF or larger may cause back current to flow through internal parasitic diodes in the event of a supply voltage ground fault, causing damage to internal IC elements. For applications where such modes are anticipated, implement a bypass diode or other preventive measure.

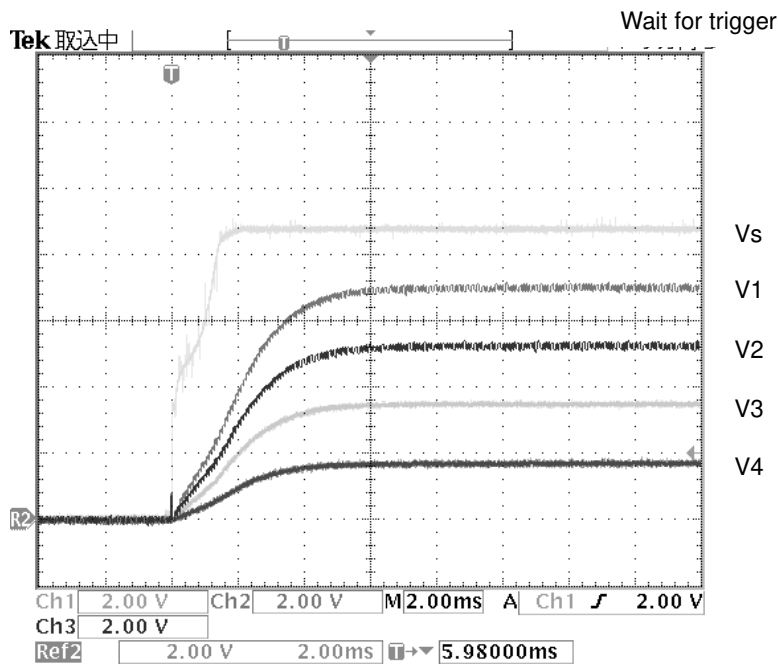

Fig. 37 Gamma Correction Voltage Startup Waveform

●Application Examples

* Although ROHM is sure that the application examples are recommendable ones, further check the characteristics of components that require high precision before using them. When a circuit is used modifying the externally connected circuit constant, be sure to decide allowing sufficient margins considering the dispersion of values by external parts as well as our IC including not only the static but also the transient characteristic.

For the patent, we have not acquired the sufficient confirmation. Please acknowledge the status.

(1) When the charge pump is removed from the DC/DC converter to make it 3-channel output mode:

It is possible to create the charge pump by using the switching operation of DC/DC converter. When the application shown in the following diagram is used, 1-channel DC/DC converter output, 1-channel positive side charge pump and 1-channel negative side charge pump can be output as a total of 3 channels.

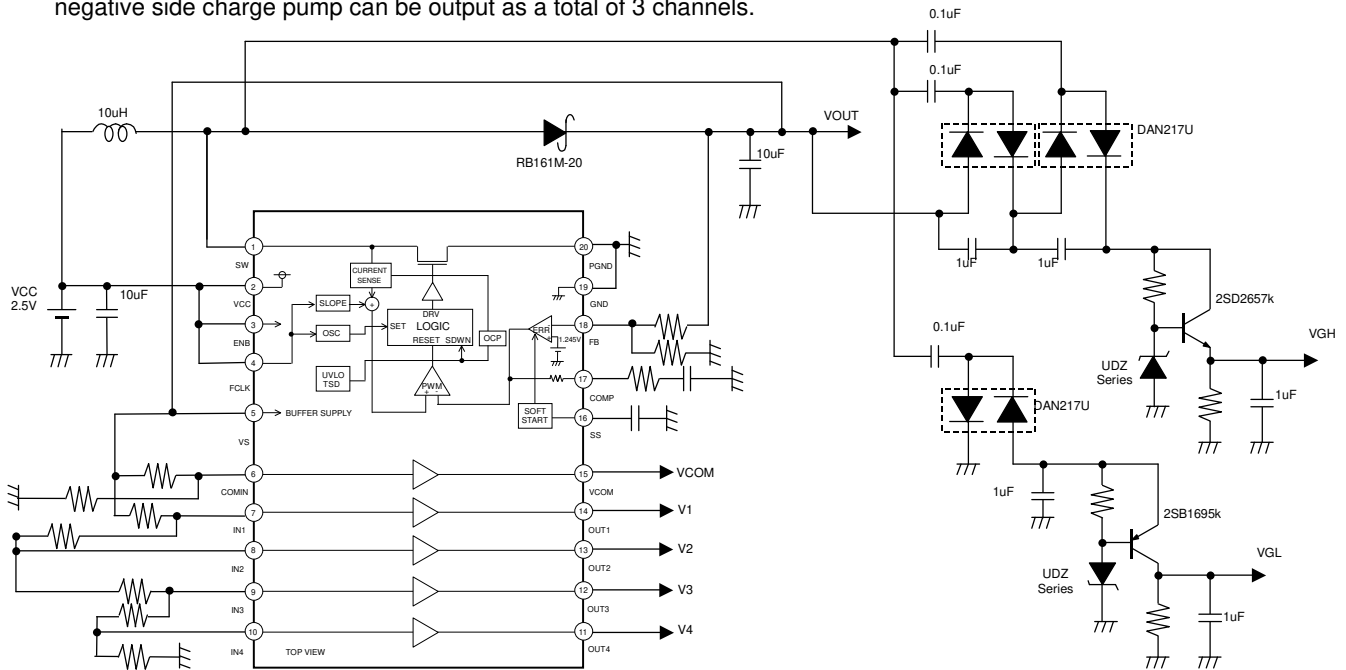

Fig. 38 3 ch Application Circuit Diagram Example

(2) When the output voltage is set to 0 V:

Since the switch does not exist between the input and output in the application using the step-up type DC/DC converter, the output voltage is generated even if the IC is turned off. When it is intended to keep the output voltage 0 V until IC operates, insert the switch as shown in the following circuit diagram.

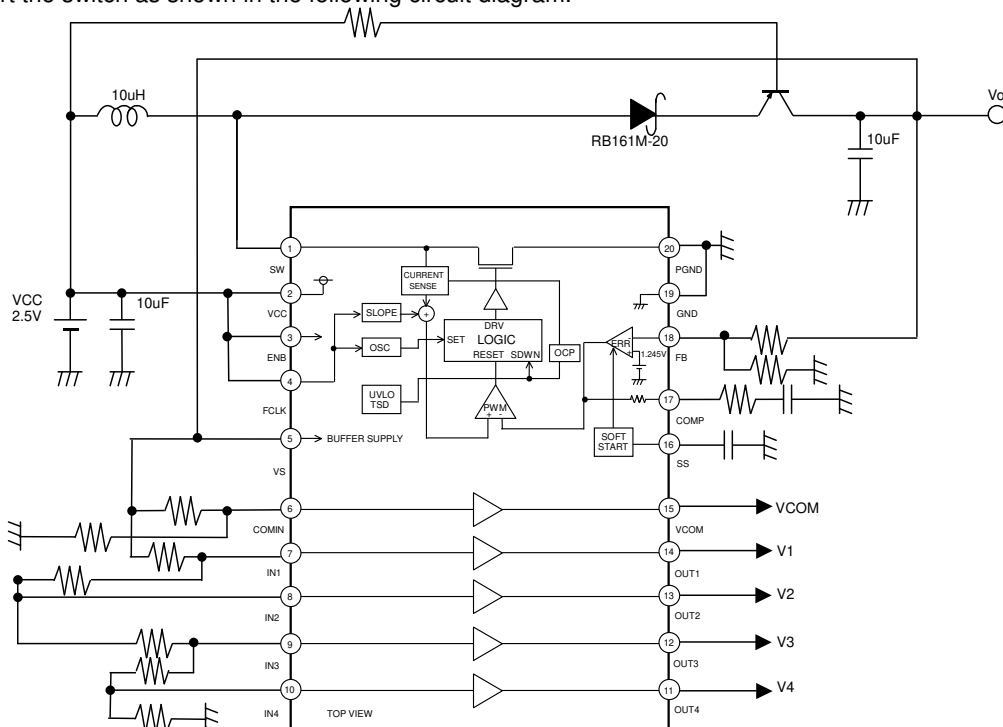

Fig. 39 Switch Application Circuit Diagram Example

● I/O Equivalent Circuit Diagrams

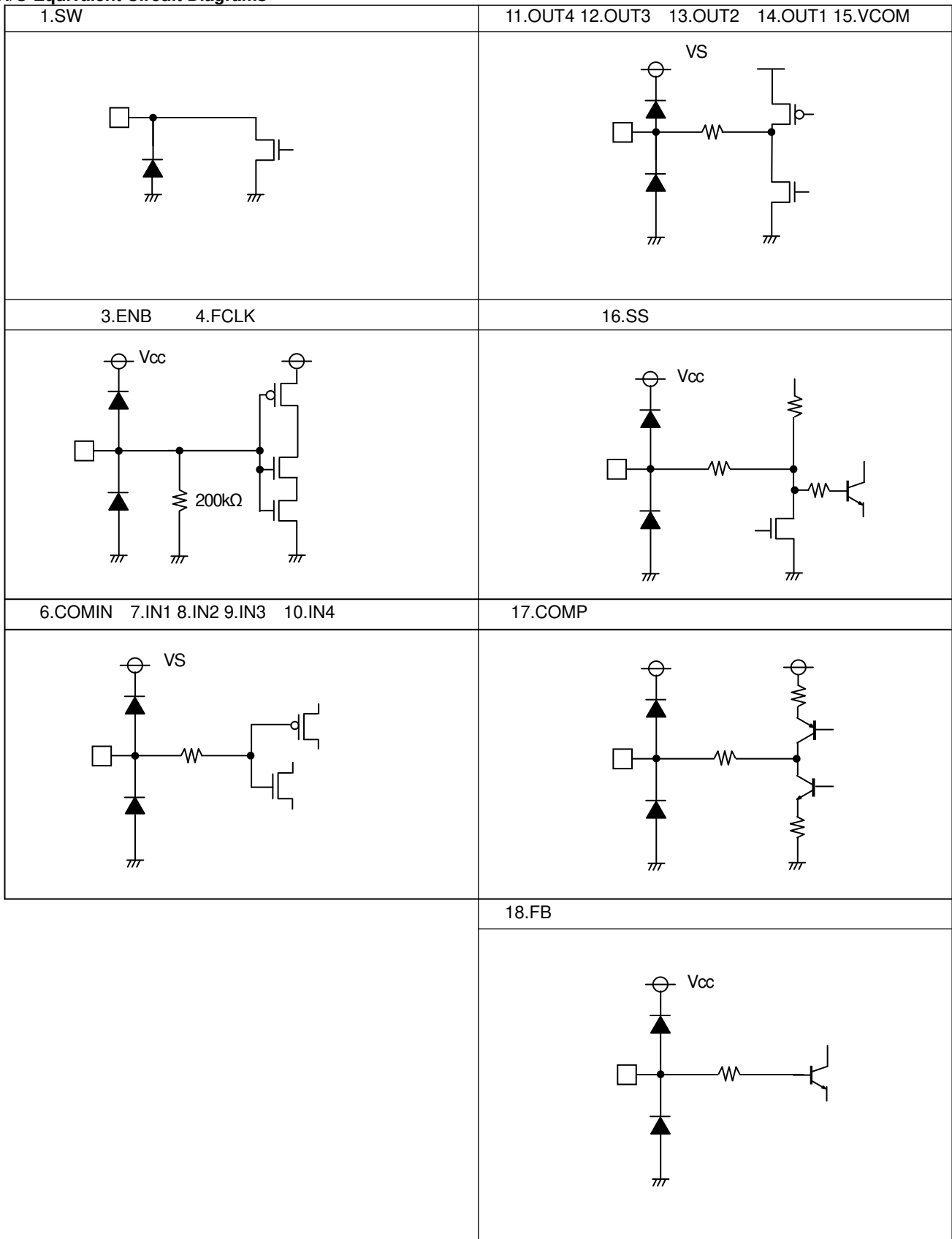

Fig.40 I/O Equivalent Circuit Diagrams

●Notes for use

- 1) Absolute maximum ratings
Use of the IC in excess of absolute maximum ratings such as the applied voltage or operating temperature range may result in IC damage. Assumptions should not be made regarding the state of the IC (short mode or open mode) when such damage is suffered. A physical safety measure such as a fuse should be implemented when use of the IC in a special mode where the absolute maximum ratings may be exceeded is anticipated.
- 2) GND potential
Ensure a minimum GND pin potential in all operating conditions.
- 3) Setting of heat
Use a thermal design that allows for a sufficient margin in light of the power dissipation (Pd) in actual operating conditions.
- 4) Pin short and mistake fitting
Use caution when orienting and positioning the IC for mounting on an application board. Improper mounting may result in damage to the IC. Shorts between output pins or between output pins and the power supply and GND pins caused by the presence of a foreign object may result in damage to the IC.
- 5) Actions in strong magnetic field
Use caution when using the IC in the presence of a strong magnetic field as doing so may cause the IC to malfunction.
- 6) Testing on application boards
When testing the IC on an application board, connecting a capacitor to a pin with low impedance subjects the IC to stress. Always discharge capacitors after each process or step. Ground the IC during assembly steps as an antistatic measure, and use similar caution when transporting or storing the IC. Always turn the IC's power supply off before connecting it to or removing it from a jig or fixture during the inspection process.
- 7) Ground wiring patterns
When using both small signal and large current GND patterns, it is recommended to isolate the two ground patterns, placing a single ground point at the application's reference point so that the pattern wiring resistance and voltage variations caused by large currents do not cause variations in the small signal ground voltage. Be careful not to change the GND wiring patterns of any external components.

- 8) This monolithic IC contains P+ isolation and P substrate layers between adjacent elements in order to keep them isolated. P/N junctions are formed at the intersection of these P layers with the N layers of other elements to create a variety of parasitic elements. For example, when the resistors and transistors are connected to the pins as shown in Fig. 41, a parasitic diode or a transistor operates by inverting the pin voltage and GND voltage.
The formation of parasitic elements as a result of the relationships of the potentials of different pins is an inevitable result of the IC's architecture. The operation of parasitic elements can cause interference with circuit operation as well as IC malfunction and damage. For these reasons, it is necessary to use caution so that the IC is not used in a way that will trigger the operation of parasitic elements, such as the application of voltages lower than the GND (P substrate) voltage to input and output pins.

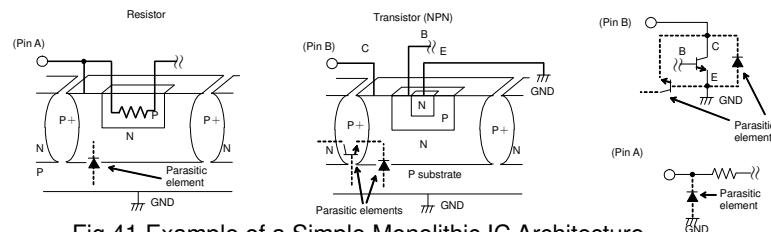

Fig.41 Example of a Simple Monolithic IC Architecture

- 9) Overcurrent protection circuits
An overcurrent protection circuit designed according to the output current is incorporated for the prevention of IC destruction that may result in the event of load shorting. This protection circuit is effective in preventing damage due to sudden and unexpected accidents. However, the IC should not be used in applications characterized by the continuous operation or transitioning of the protection circuits. At the time of thermal designing, keep in mind that the current capacity has negative characteristics to temperatures.
- 10) Thermal shutdown circuit (TSD)
This IC incorporates a built-in TSD circuit for the protection from thermal destruction. The IC should be used within the specified power dissipation range. However, in the event that the IC continues to be operated in excess of its power dissipation limits, the attendant rise in the chip's temperature T_j will trigger the temperature protection circuit to turn off all output power elements. The circuit automatically resets once the chip's temperature T_j drops.
Operation of the TSD circuit presumes that the IC's absolute maximum ratings have been exceeded. Application designs should never make use of the TSD circuit.
- 11) Testing on application boards
At the time of inspection of the installation boards, when the capacitor is connected to the pin with low impedance, be sure to discharge electricity per process because it may load stresses to the IC. Always turn the IC's power supply off before connecting it to or removing it from a jig or fixture during the inspection process. Ground the IC during assembly steps as an antistatic measure, and use similar caution when transporting or storing the IC.

● Power Dissipation Reduction

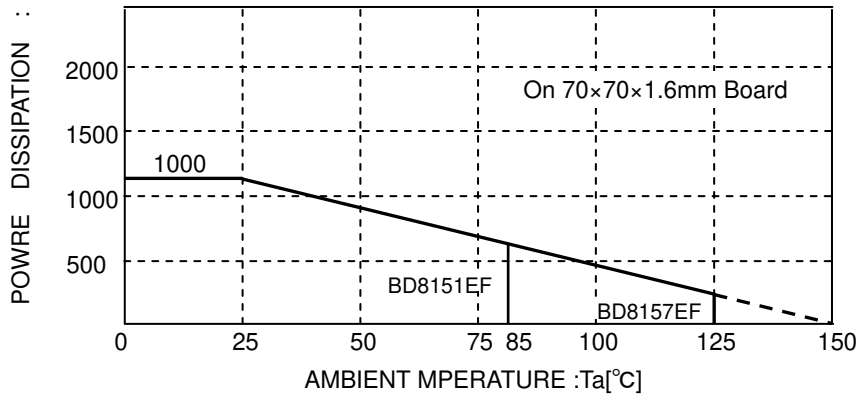
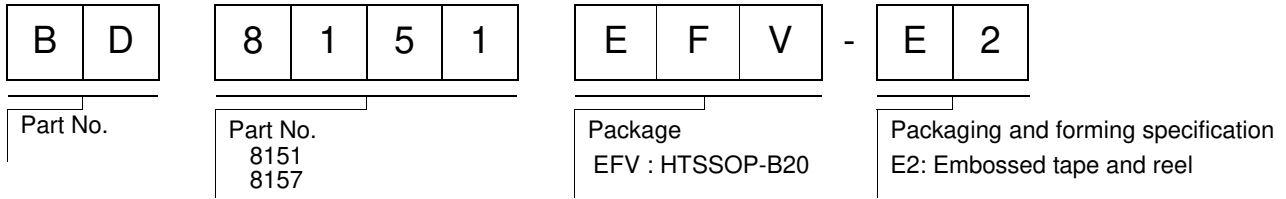
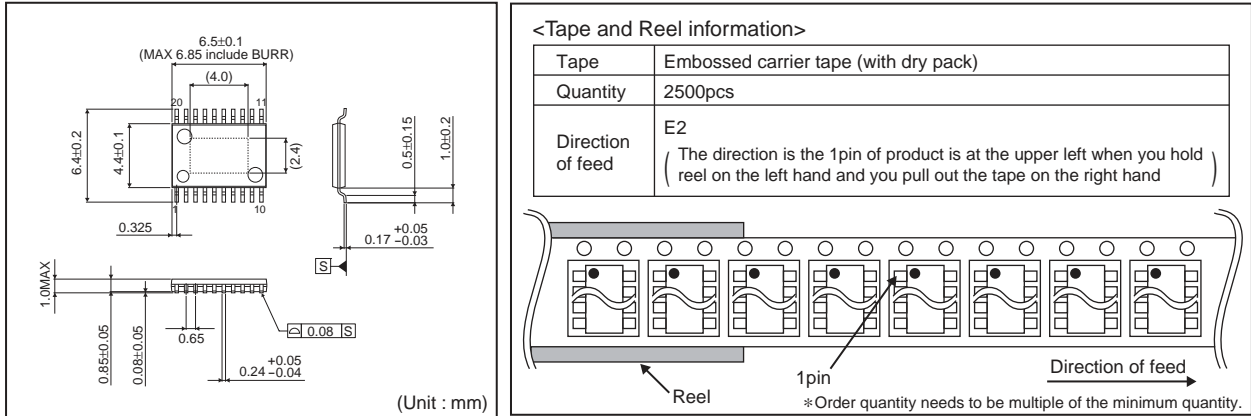

Fig.42 Power Dissipation Reduction

●Ordering part number



HTSSOP-B20



Notice

Precaution on using ROHM Products

- Our Products are designed and manufactured for application in ordinary electronic equipments (such as AV equipment, OA equipment, telecommunication equipment, home electronic appliances, amusement equipment, etc.). If you intend to use our Products in devices requiring extremely high reliability (such as medical equipment ^(Note 1), transport equipment, traffic equipment, aircraft/spacecraft, nuclear power controllers, fuel controllers, car equipment including car accessories, safety devices, etc.) and whose malfunction or failure may cause loss of human life, bodily injury or serious damage to property ("Specific Applications"), please consult with the ROHM sales representative in advance. Unless otherwise agreed in writing by ROHM in advance, ROHM shall not be in any way responsible or liable for any damages, expenses or losses incurred by you or third parties arising from the use of any ROHM's Products for Specific Applications.

(Note1) Medical Equipment Classification of the Specific Applications

JAPAN	USA	EU	CHINA
CLASS III	CLASS III	CLASS II b	CLASS III
CLASS IV		CLASS III	

- ROHM designs and manufactures its Products subject to strict quality control system. However, semiconductor products can fail or malfunction at a certain rate. Please be sure to implement, at your own responsibilities, adequate safety measures including but not limited to fail-safe design against the physical injury, damage to any property, which a failure or malfunction of our Products may cause. The following are examples of safety measures:
 - Installation of protection circuits or other protective devices to improve system safety
 - Installation of redundant circuits to reduce the impact of single or multiple circuit failure
- Our Products are designed and manufactured for use under standard conditions and not under any special or extraordinary environments or conditions, as exemplified below. Accordingly, ROHM shall not be in any way responsible or liable for any damages, expenses or losses arising from the use of any ROHM's Products under any special or extraordinary environments or conditions. If you intend to use our Products under any special or extraordinary environments or conditions (as exemplified below), your independent verification and confirmation of product performance, reliability, etc. prior to use, must be necessary:
 - Use of our Products in any types of liquid, including water, oils, chemicals, and organic solvents
 - Use of our Products outdoors or in places where the Products are exposed to direct sunlight or dust
 - Use of our Products in places where the Products are exposed to sea wind or corrosive gases, including Cl₂, H₂S, NH₃, SO₂, and NO₂
 - Use of our Products in places where the Products are exposed to static electricity or electromagnetic waves
 - Use of our Products in proximity to heat-producing components, plastic cords, or other flammable items
 - Sealing or coating our Products with resin or other coating materials
 - Use of our Products without cleaning residue of flux (even if you use no-clean type fluxes, cleaning residue of flux is recommended); or Washing our Products by using water or water-soluble cleaning agents for cleaning residue after soldering
 - Use of the Products in places subject to dew condensation
- The Products are not subject to radiation-proof design.
- Please verify and confirm characteristics of the final or mounted products in using the Products.
- In particular, if a transient load (a large amount of load applied in a short period of time, such as pulse. is applied, confirmation of performance characteristics after on-board mounting is strongly recommended. Avoid applying power exceeding normal rated power; exceeding the power rating under steady-state loading condition may negatively affect product performance and reliability.
- De-rate Power Dissipation (Pd) depending on Ambient temperature (Ta). When used in sealed area, confirm the actual ambient temperature.
- Confirm that operation temperature is within the specified range described in the product specification.
- ROHM shall not be in any way responsible or liable for failure induced under deviant condition from what is defined in this document.

Precaution for Mounting / Circuit board design

- When a highly active halogenous (chlorine, bromine, etc.) flux is used, the residue of flux may negatively affect product performance and reliability.
- In principle, the reflow soldering method must be used; if flow soldering method is preferred, please consult with the ROHM representative in advance.

For details, please refer to ROHM Mounting specification

Precautions Regarding Application Examples and External Circuits

1. If change is made to the constant of an external circuit, please allow a sufficient margin considering variations of the characteristics of the Products and external components, including transient characteristics, as well as static characteristics.
2. You agree that application notes, reference designs, and associated data and information contained in this document are presented only as guidance for Products use. Therefore, in case you use such information, you are solely responsible for it and you must exercise your own independent verification and judgment in the use of such information contained in this document. ROHM shall not be in any way responsible or liable for any damages, expenses or losses incurred by you or third parties arising from the use of such information.

Precaution for Electrostatic

This Product is electrostatic sensitive product, which may be damaged due to electrostatic discharge. Please take proper caution in your manufacturing process and storage so that voltage exceeding the Products maximum rating will not be applied to Products. Please take special care under dry condition (e.g. Grounding of human body / equipment / solder iron, isolation from charged objects, setting of Ionizer, friction prevention and temperature / humidity control).

Precaution for Storage / Transportation

1. Product performance and soldered connections may deteriorate if the Products are stored in the places where:
 - [a] the Products are exposed to sea winds or corrosive gases, including Cl₂, H₂S, NH₃, SO₂, and NO₂
 - [b] the temperature or humidity exceeds those recommended by ROHM
 - [c] the Products are exposed to direct sunshine or condensation
 - [d] the Products are exposed to high Electrostatic
2. Even under ROHM recommended storage condition, solderability of products out of recommended storage time period may be degraded. It is strongly recommended to confirm solderability before using Products of which storage time is exceeding the recommended storage time period.
3. Store / transport cartons in the correct direction, which is indicated on a carton with a symbol. Otherwise bent leads may occur due to excessive stress applied when dropping of a carton.
4. Use Products within the specified time after opening a humidity barrier bag. Baking is required before using Products of which storage time is exceeding the recommended storage time period.

Precaution for Product Label

QR code printed on ROHM Products label is for ROHM's internal use only.

Precaution for Disposition

When disposing Products please dispose them properly using an authorized industry waste company.

Precaution for Foreign Exchange and Foreign Trade act

Since our Products might fall under controlled goods prescribed by the applicable foreign exchange and foreign trade act, please consult with ROHM representative in case of export.

Precaution Regarding Intellectual Property Rights

1. All information and data including but not limited to application example contained in this document is for reference only. ROHM does not warrant that foregoing information or data will not infringe any intellectual property rights or any other rights of any third party regarding such information or data. ROHM shall not be in any way responsible or liable for infringement of any intellectual property rights or other damages arising from use of such information or data.:
2. No license, expressly or implied, is granted hereby under any intellectual property rights or other rights of ROHM or any third parties with respect to the information contained in this document.

Other Precaution

1. This document may not be reprinted or reproduced, in whole or in part, without prior written consent of ROHM.
2. The Products may not be disassembled, converted, modified, reproduced or otherwise changed without prior written consent of ROHM.
3. In no event shall you use in any way whatsoever the Products and the related technical information contained in the Products or this document for any military purposes, including but not limited to, the development of mass-destruction weapons.
4. The proper names of companies or products described in this document are trademarks or registered trademarks of ROHM, its affiliated companies or third parties.

General Precaution

1. Before you use our Products, you are requested to carefully read this document and fully understand its contents. ROHM shall not be in any way responsible or liable for failure, malfunction or accident arising from the use of any ROHM's Products against warning, caution or note contained in this document.
2. All information contained in this document is current as of the issuing date and subject to change without any prior notice. Before purchasing or using ROHM's Products, please confirm the latest information with a ROHM sales representative.
3. The information contained in this document is provided on an "as is" basis and ROHM does not warrant that all information contained in this document is accurate and/or error-free. ROHM shall not be in any way responsible or liable for any damages, expenses or losses incurred by you or third parties resulting from inaccuracy or errors of or concerning such information.