

# CD74FCT824A

## BiCMOS 9-BIT BUS-INTERFACE FLIP-FLOP WITH 3-STATE OUTPUTS

SCBS724A – JULY 2000 – REVISED JULY 2000

- BiCMOS Technology With Low Quiescent Power
- Buffered Inputs
- Inverted Outputs
- Input/Output Isolation From  $V_{CC}$
- Controlled Output Edge Rates
- 48-mA Output Sink Current
- Output Voltage Swing Limited to 3.7 V
- SCR Latch-Up-Resistant BiCMOS Process and Circuit Design
- Packaged in Standard Plastic DIP

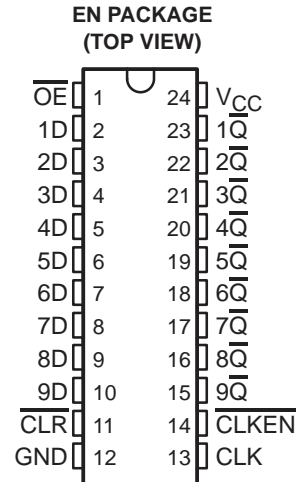

### description

The CD74FCT824A is a 9-bit, D-type, 3-state, positive-edge-triggered flip-flop, using a small-geometry BiCMOS technology. The output stage is a combination of bipolar and CMOS transistors that limits the output high level to two diode drops below  $V_{CC}$ . This resultant lowering of output swing (0 V to 3.7 V) reduces power-bus ringing [a source of electromagnetic interference (EMI)] and minimizes  $V_{CC}$  bounce and ground bounce and their effect during simultaneous output switching. The output configuration also enhances switching speed and is capable of sinking 48 mA. It is designed specifically for driving highly capacitive or relatively low-impedance loads. It is particularly suitable for implementing wider buffer registers, I/O ports, bidirectional bus drivers with parity, and working registers.

The flip-flops enter data into their registers on the low-to-high transition of the clock (CLK). The output-enable (OE) input controls the 3-state outputs and is independent of the register operation. The nine bit-wide buffered registers with clock enable ( $\overline{\text{CLKEN}}$ ) and CLR inputs are ideal for parity bus interfacing in high-performance microprogrammed systems. Taking  $\overline{\text{CLKEN}}$  high disables the clock buffer, latching the outputs. Taking the clear (CLR) input low causes the nine Q outputs to go low, independently of the clock. The device provides inverted outputs.

The CD74FCT824A is characterized for operation from 0°C to 70°C.

**FUNCTION TABLE**  
(each flip-flop)

INPUTS					OUTPUT
$\overline{\text{OE}}$	$\overline{\text{CLR}}$	$\overline{\text{CLKEN}}$	CLK	D	$\overline{\text{Q}}$
L	L	X	X	X	L
L	H	L	↑	H	L
L	H	L	↑	L	H
L	H	H	X	X	$Q_0$
H	X	X	X	X	Z



Please be aware that an important notice concerning availability, standard warranty, and use in critical applications of Texas Instruments semiconductor products and disclaimers thereto appears at the end of this data sheet.

PRODUCTION DATA information is current as of publication date. Products conform to specifications per the terms of Texas Instruments standard warranty. Production processing does not necessarily include testing of all parameters.

**TEXAS  
INSTRUMENTS**

POST OFFICE BOX 655303 • DALLAS, TEXAS 75265

Copyright © 2000, Texas Instruments Incorporated

# CD74FCT824A BiCMOS 9-BIT BUS-INTERFACE FLIP-FLOP WITH 3-STATE OUTPUTS

SCBS724A – JULY 2000 – REVISED JULY 2000

## logic symbol†

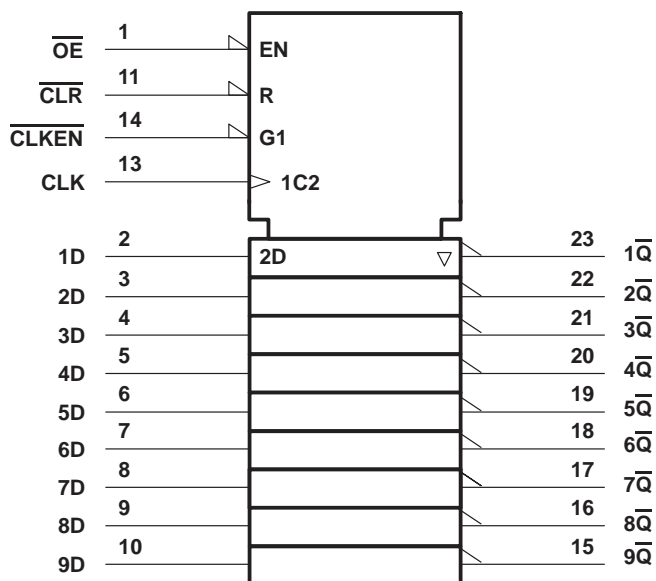

† This symbol is in accordance with ANSI/IEEE Std 91-1984 and IEC Publication 617-12.

## logic diagram (positive logic)

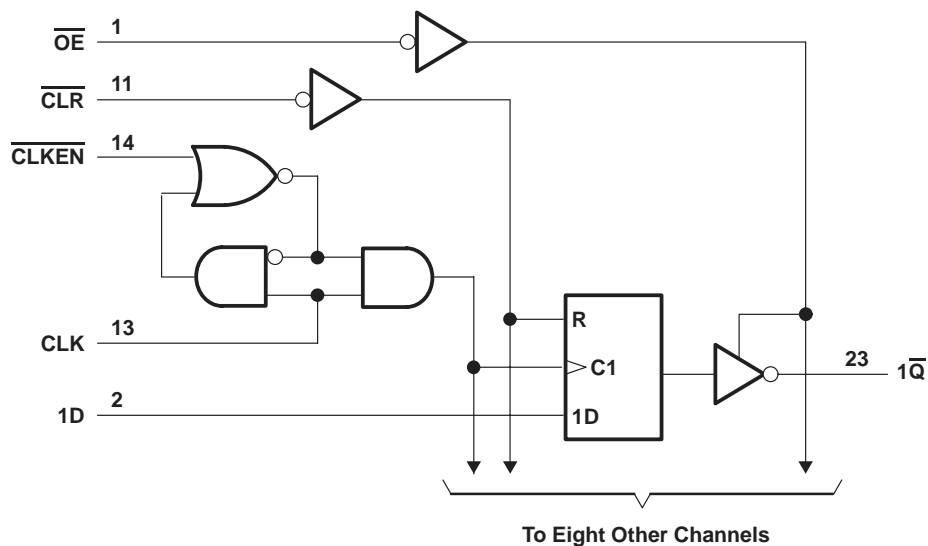

# CD74FCT824A

## BiCMOS 9-BIT BUS-INTERFACE FLIP-FLOP WITH 3-STATE OUTPUTS

SCBS724A – JULY 2000 – REVISED JULY 2000

### absolute maximum ratings over operating free-air temperature range (unless otherwise noted)†

DC supply voltage range, $V_{CC}$ .....	-0.5 V to 6 V
DC input clamp current, $I_{IK}$ ( $V_I < -0.5$ V) .....	-20 mA
DC output clamp current, $I_{OK}$ ( $V_O < -0.5$ V) .....	-50 mA
DC output sink current per output pin, $I_{OL}$ .....	70 mA
DC output source current per output pin, $I_{OH}$ .....	-30 mA
Continuous current through $V_{CC}$ , ( $I_{CC}$ ) .....	234 mA
Continuous current through GND .....	453 mA
Package thermal impedance, $\theta_{JA}$ (see Note 1) .....	67°C/W
Storage temperature range, $T_{stg}$ .....	-65°C to 150°C

† Stresses beyond those listed under “absolute maximum ratings” may cause permanent damage to the device. These are stress ratings only, and functional operation of the device at these or any other conditions beyond those indicated under “recommended operating conditions” is not implied. Exposure to absolute-maximum-rated conditions for extended periods may affect device reliability.

NOTE 1: The package thermal impedance is calculated in accordance with JESD 51.

### recommended operating conditions (see Note 2)

	MIN	MAX	UNIT
$V_{CC}$ Supply voltage	4.75	5.25	V
$V_{IH}$ High-level input voltage	2		V
$V_{IL}$ Low-level input voltage		0.8	V
$V_I$ Input voltage	0	$V_{CC}$	V
$V_O$ Output voltage	0	$V_{CC}$	V
$I_{OH}$ High-level output current		-15	mA
$I_{OL}$ Low-level output current		48	mA
$\Delta t/\Delta v$ Input transition rise or fall rate	0	10	ns/V
$T_A$ Operating free-air temperature	0	70	°C

NOTE 2: All unused inputs of the device must be held at  $V_{CC}$  or GND to ensure proper device operation. Refer to the TI application report, *Implications of Slow or Floating CMOS Inputs*, literature number SCBA004.

### electrical characteristics over recommended operating free-air temperature range (unless otherwise noted)

PARAMETER	TEST CONDITIONS	$V_{CC}$	$T_A = 25^\circ\text{C}$		MIN	MAX	UNIT
			MIN	MAX			
$V_{IK}$	$I_I = -18$ mA	4.75 V		-1.2		-1.2	V
$V_{OH}$	$I_{OH} = -15$ mA	4.75 V	2.4		2.4		V
$V_{OL}$	$I_{OL} = 48$ mA	4.75 V		0.55		0.55	V
$I_I$	$V_I = V_{CC}$ or GND	5.25 V		$\pm 0.1$		$\pm 1$	$\mu\text{A}$
$I_{OZ}$	$V_O = V_{CC}$ or GND	5.25 V		$\pm 0.5$		$\pm 10$	$\mu\text{A}$
$I_{OS}^\ddagger$	$V_I = V_{CC}$ or GND, $V_O = 0$	5.25 V		-75		-75	mA
$I_{CC}$	$V_I = V_{CC}$ or GND, $I_O = 0$	5.25 V		8		80	$\mu\text{A}$
$\Delta I_{CC}^\S$	One input at 3.4 V, Other inputs at $V_{CC}$ or GND	5.25 V		1.6		1.6	mA
$C_i$	$V_I = V_{CC}$ or GND			10		10	pF
$C_o$	$V_O = V_{CC}$ or GND			15		15	pF

‡ Not more than one output should be tested at a time, and the duration of the test should not exceed 100 ms.

§ This is the increase in supply current for each input at one of the specified TTL voltage levels rather than 0 V or  $V_{CC}$ .



**CD74FCT824A**  
**BiCMOS 9-BIT BUS-INTERFACE FLIP-FLOP**  
**WITH 3-STATE OUTPUTS**

SCBS724A – JULY 2000 – REVISED JULY 2000

timing requirements over recommended operating temperature conditions (unless otherwise noted) (see Figure 1)

		MIN	MAX	UNIT
$f_{\text{clock}}$	Clock frequency		70	MHz
$t_w$	Pulse duration	$\overline{\text{CLR}}$ low	7	ns
		CLK high or low	7	
$t_{\text{su}}$	Setup time	$\overline{\text{CLR}}$ inactive before CLK $\uparrow$	4	ns
		Data before CLK $\uparrow$	4	
		$\overline{\text{CLKEN}}$ low before CLK $\uparrow$	4	
$t_h$	Hold time	Data after CLK $\uparrow$	2	ns
		$\overline{\text{CLKEN}}$ low after CLK $\uparrow$	2	

switching characteristics over recommended operating temperature conditions (unless otherwise noted) (see Figure 1)

PARAMETER	FROM (INPUT)	TO (OUTPUT)	$T_A = 25^\circ\text{C}$	MIN	MAX	UNIT
			TYP			
$f_{\text{max}}$				70		MHz
$t_{\text{pd}}$	CLK	$\overline{\text{Q}}$	7.5	1.5	10	ns
$t_{\text{PHL}}$	$\overline{\text{CLR}}$	$\overline{\text{Q}}$	10.5	1.5	14	ns
$t_{\text{en}}$	$\overline{\text{OE}}$	$\overline{\text{Q}}$	9	1.5	12	ns
$t_{\text{dis}}$	$\overline{\text{OE}}$	$\overline{\text{Q}}$	6	1.5	8	ns

noise characteristics,  $V_{\text{CC}} = 5 \text{ V}$ ,  $C_L = 50 \text{ pF}$ ,  $T_A = 25^\circ\text{C}$

PARAMETER		MIN	TYP	MAX	UNIT
$V_{\text{OL(P)}}$	Quiet output, maximum dynamic $V_{\text{OL}}$		1		V
$V_{\text{OH(V)}}$	Quiet output, minimum dynamic $V_{\text{OH}}$		0.5		V
$V_{\text{IH(D)}}$	High-level dynamic input voltage	2			V
$V_{\text{IL(D)}}$	Low-level dynamic input voltage			0.8	V



PARAMETER MEASUREMENT INFORMATION

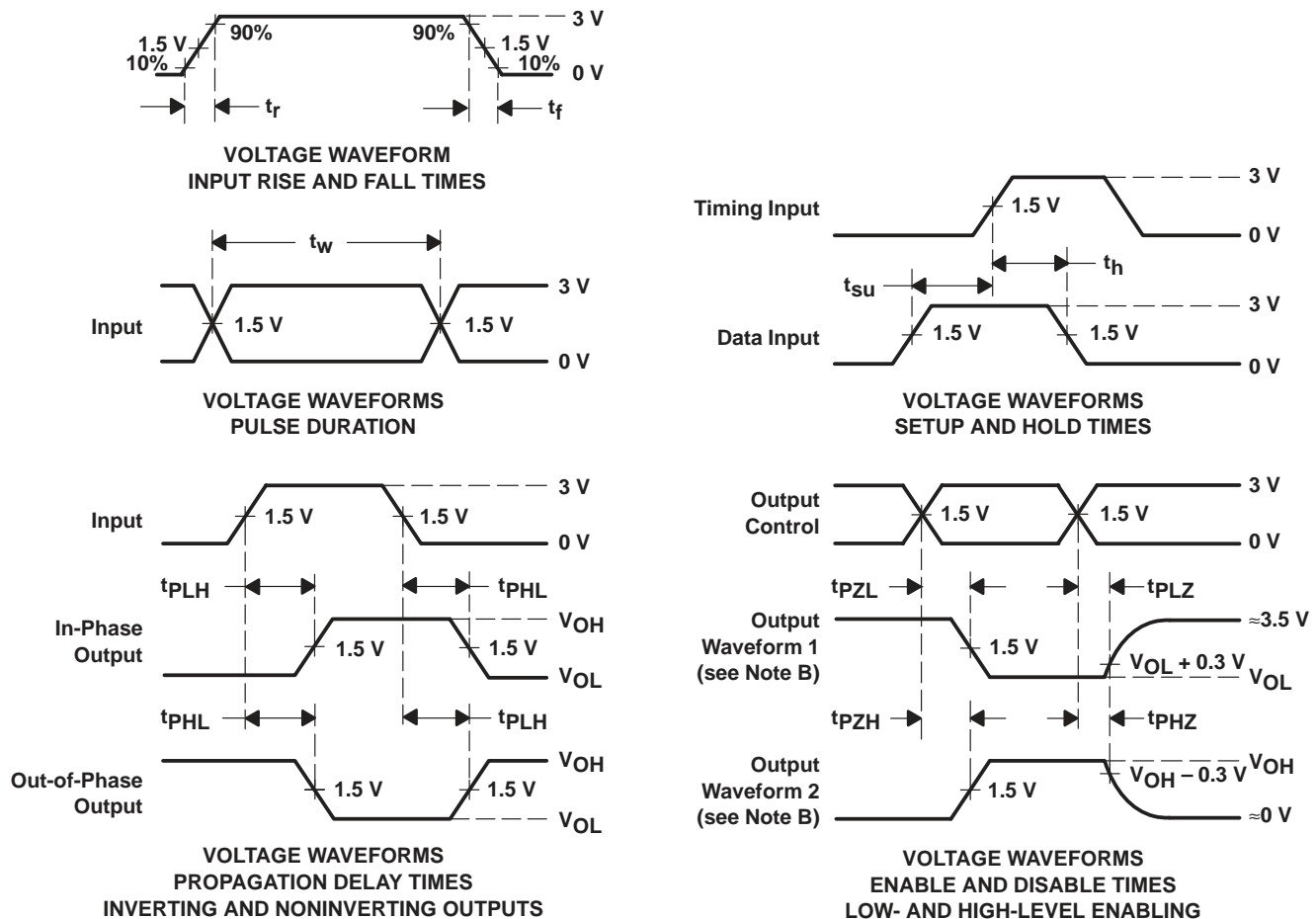
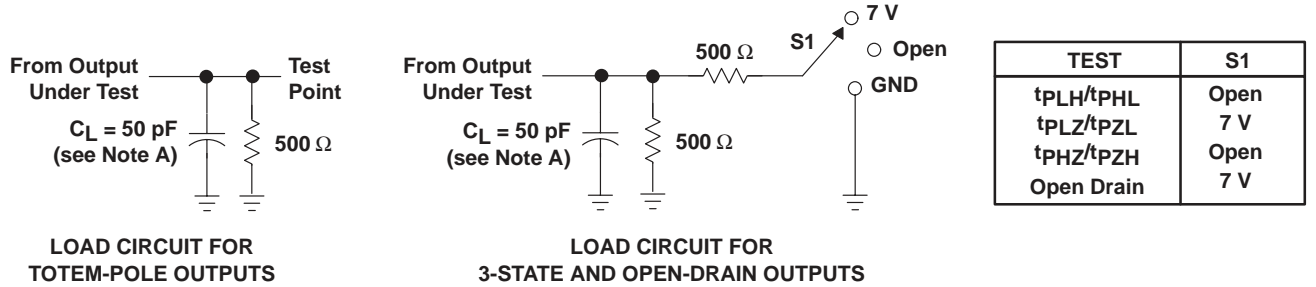

- NOTES: A.  $C_L$  includes probe and jig capacitance.  
 B. Waveform 1 is for an output with internal conditions such that the output is low except when disabled by the output control. Waveform 2 is for an output with internal conditions such that the output is high except when disabled by the output control.  
 C. All input pulses are supplied by generators having the following characteristics: PRR  $\leq 1 \text{ MHz}$ ,  $Z_O = 50 \Omega$ ,  $t_r$  and  $t_f = 2.5 \text{ ns}$ .  
 D. The outputs are measured one at a time with one input transition per measurement.  
 E.  $t_{PLZ}$  and  $t_{PHZ}$  are the same as  $t_{dis}$ .  
 F.  $t_{PZL}$  and  $t_{PZH}$  are the same as  $t_{en}$ .  
 G.  $t_{PHL}$  and  $t_{PLH}$  are the same as  $t_{pd}$ .

Figure 1. Load Circuit and Voltage Waveforms

**PACKAGING INFORMATION**

Orderable Device	Status (1)	Package Type	Package Drawing	Pins	Package Qty	Eco Plan (2)	Lead/Ball Finish	MSL Peak Temp (3)	Op Temp (°C)	Top-Side Markings (4)	Samples
CD74FCT824AEN	OBSOLETE	PDIP	NT	24		TBD	Call TI	Call TI	0 to 70		

(1) The marketing status values are defined as follows:

**ACTIVE:** Product device recommended for new designs.

**LIFEBUY:** TI has announced that the device will be discontinued, and a lifetime-buy period is in effect.

**NRND:** Not recommended for new designs. Device is in production to support existing customers, but TI does not recommend using this part in a new design.

**PREVIEW:** Device has been announced but is not in production. Samples may or may not be available.

**OBSOLETE:** TI has discontinued the production of the device.

(2) Eco Plan - The planned eco-friendly classification: Pb-Free (RoHS), Pb-Free (RoHS Exempt), or Green (RoHS & no Sb/Br) - please check <http://www.ti.com/productcontent> for the latest availability information and additional product content details.

**TBD:** The Pb-Free/Green conversion plan has not been defined.

**Pb-Free (RoHS):** TI's terms "Lead-Free" or "Pb-Free" mean semiconductor products that are compatible with the current RoHS requirements for all 6 substances, including the requirement that lead not exceed 0.1% by weight in homogeneous materials. Where designed to be soldered at high temperatures, TI Pb-Free products are suitable for use in specified lead-free processes.

**Pb-Free (RoHS Exempt):** This component has a RoHS exemption for either 1) lead-based flip-chip solder bumps used between the die and package, or 2) lead-based die adhesive used between the die and leadframe. The component is otherwise considered Pb-Free (RoHS compatible) as defined above.

**Green (RoHS & no Sb/Br):** TI defines "Green" to mean Pb-Free (RoHS compatible), and free of Bromine (Br) and Antimony (Sb) based flame retardants (Br or Sb do not exceed 0.1% by weight in homogeneous material)

(3) MSL, Peak Temp. -- The Moisture Sensitivity Level rating according to the JEDEC industry standard classifications, and peak solder temperature.

(4) Multiple Top-Side Markings will be inside parentheses. Only one Top-Side Marking contained in parentheses and separated by a "-" will appear on a device. If a line is indented then it is a continuation of the previous line and the two combined represent the entire Top-Side Marking for that device.

**Important Information and Disclaimer:** The information provided on this page represents TI's knowledge and belief as of the date that it is provided. TI bases its knowledge and belief on information provided by third parties, and makes no representation or warranty as to the accuracy of such information. Efforts are underway to better integrate information from third parties. TI has taken and continues to take reasonable steps to provide representative and accurate information but may not have conducted destructive testing or chemical analysis on incoming materials and chemicals. TI and TI suppliers consider certain information to be proprietary, and thus CAS numbers and other limited information may not be available for release.

In no event shall TI's liability arising out of such information exceed the total purchase price of the TI part(s) at issue in this document sold by TI to Customer on an annual basis.

# MECHANICAL DATA

NT (R-PDIP-T\*\*)

PLASTIC DUAL-IN-LINE PACKAGE

24 PINS SHOWN

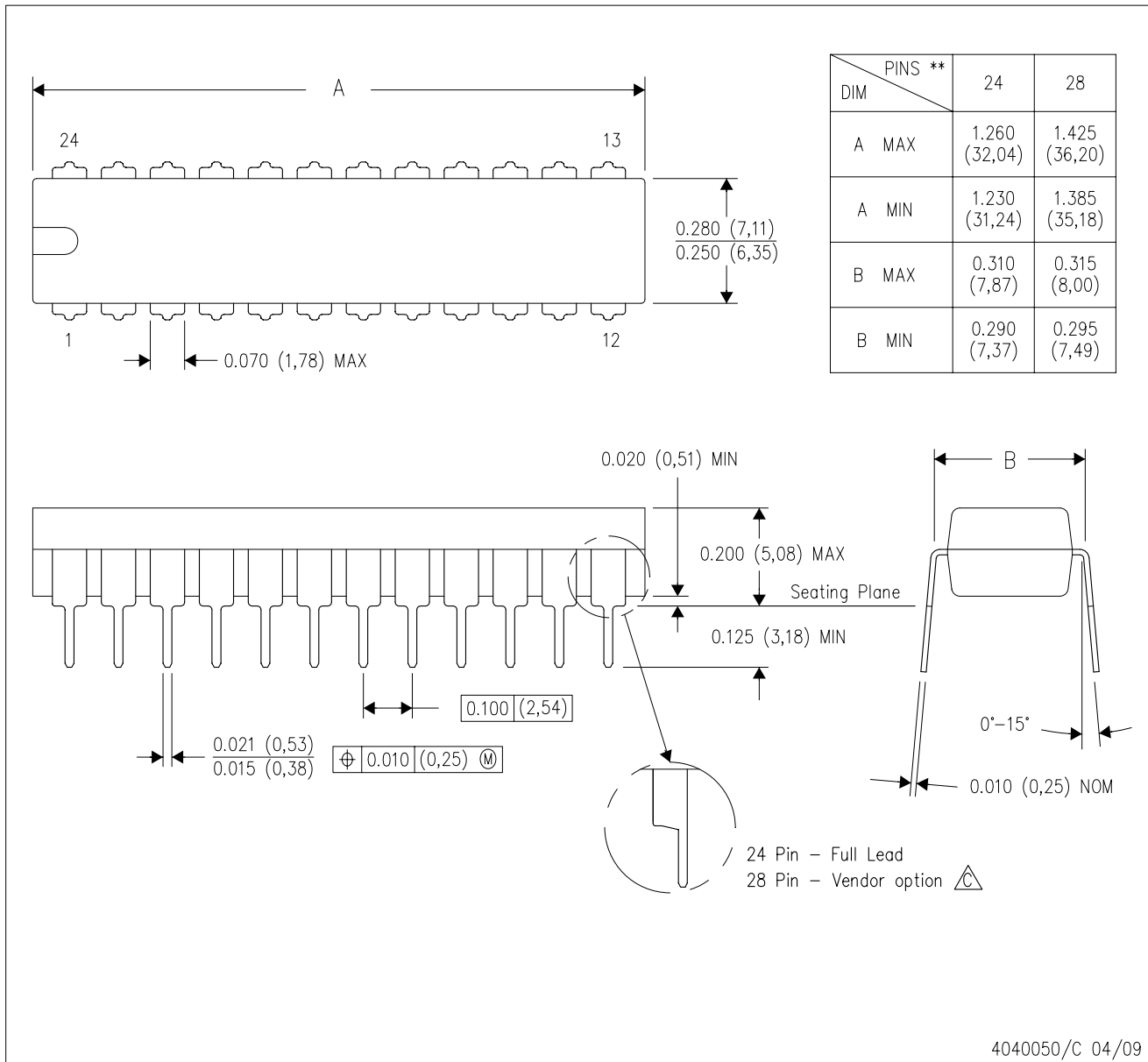

NOTES: A. All linear dimensions are in millimeters. Dimensioning and tolerancing per ASME Y14.5M-1994.

B. This drawing is subject to change without notice.

 The 28 pin end lead shoulder width is a vendor option, either half or full width.

## IMPORTANT NOTICE

Texas Instruments Incorporated and its subsidiaries (TI) reserve the right to make corrections, enhancements, improvements and other changes to its semiconductor products and services per JESD46, latest issue, and to discontinue any product or service per JESD48, latest issue. Buyers should obtain the latest relevant information before placing orders and should verify that such information is current and complete. All semiconductor products (also referred to herein as "components") are sold subject to TI's terms and conditions of sale supplied at the time of order acknowledgment.

TI warrants performance of its components to the specifications applicable at the time of sale, in accordance with the warranty in TI's terms and conditions of sale of semiconductor products. Testing and other quality control techniques are used to the extent TI deems necessary to support this warranty. Except where mandated by applicable law, testing of all parameters of each component is not necessarily performed.

TI assumes no liability for applications assistance or the design of Buyers' products. Buyers are responsible for their products and applications using TI components. To minimize the risks associated with Buyers' products and applications, Buyers should provide adequate design and operating safeguards.

TI does not warrant or represent that any license, either express or implied, is granted under any patent right, copyright, mask work right, or other intellectual property right relating to any combination, machine, or process in which TI components or services are used. Information published by TI regarding third-party products or services does not constitute a license to use such products or services or a warranty or endorsement thereof. Use of such information may require a license from a third party under the patents or other intellectual property of the third party, or a license from TI under the patents or other intellectual property of TI.

Reproduction of significant portions of TI information in TI data books or data sheets is permissible only if reproduction is without alteration and is accompanied by all associated warranties, conditions, limitations, and notices. TI is not responsible or liable for such altered documentation. Information of third parties may be subject to additional restrictions.

Resale of TI components or services with statements different from or beyond the parameters stated by TI for that component or service voids all express and any implied warranties for the associated TI component or service and is an unfair and deceptive business practice. TI is not responsible or liable for any such statements.

Buyer acknowledges and agrees that it is solely responsible for compliance with all legal, regulatory and safety-related requirements concerning its products, and any use of TI components in its applications, notwithstanding any applications-related information or support that may be provided by TI. Buyer represents and agrees that it has all the necessary expertise to create and implement safeguards which anticipate dangerous consequences of failures, monitor failures and their consequences, lessen the likelihood of failures that might cause harm and take appropriate remedial actions. Buyer will fully indemnify TI and its representatives against any damages arising out of the use of any TI components in safety-critical applications.

In some cases, TI components may be promoted specifically to facilitate safety-related applications. With such components, TI's goal is to help enable customers to design and create their own end-product solutions that meet applicable functional safety standards and requirements. Nonetheless, such components are subject to these terms.

No TI components are authorized for use in FDA Class III (or similar life-critical medical equipment) unless authorized officers of the parties have executed a special agreement specifically governing such use.

Only those TI components which TI has specifically designated as military grade or "enhanced plastic" are designed and intended for use in military/aerospace applications or environments. Buyer acknowledges and agrees that any military or aerospace use of TI components which have **not** been so designated is solely at the Buyer's risk, and that Buyer is solely responsible for compliance with all legal and regulatory requirements in connection with such use.

TI has specifically designated certain components as meeting ISO/TS16949 requirements, mainly for automotive use. In any case of use of non-designated products, TI will not be responsible for any failure to meet ISO/TS16949.

### Products

Audio	<a href="http://www.ti.com/audio">www.ti.com/audio</a>
Amplifiers	<a href="http://amplifier.ti.com">amplifier.ti.com</a>
Data Converters	<a href="http://dataconverter.ti.com">dataconverter.ti.com</a>
DLP® Products	<a href="http://www.dlp.com">www.dlp.com</a>
DSP	<a href="http://dsp.ti.com">dsp.ti.com</a>
Clocks and Timers	<a href="http://www.ti.com/clocks">www.ti.com/clocks</a>
Interface	<a href="http://interface.ti.com">interface.ti.com</a>
Logic	<a href="http://logic.ti.com">logic.ti.com</a>
Power Mgmt	<a href="http://power.ti.com">power.ti.com</a>
Microcontrollers	<a href="http://microcontroller.ti.com">microcontroller.ti.com</a>
RFID	<a href="http://www.ti-rfid.com">www.ti-rfid.com</a>
OMAP Applications Processors	<a href="http://www.ti.com/omap">www.ti.com/omap</a>
Wireless Connectivity	<a href="http://www.ti.com/wirelessconnectivity">www.ti.com/wirelessconnectivity</a>

### Applications

Automotive and Transportation	<a href="http://www.ti.com/automotive">www.ti.com/automotive</a>
Communications and Telecom	<a href="http://www.ti.com/communications">www.ti.com/communications</a>
Computers and Peripherals	<a href="http://www.ti.com/computers">www.ti.com/computers</a>
Consumer Electronics	<a href="http://www.ti.com/consumer-apps">www.ti.com/consumer-apps</a>
Energy and Lighting	<a href="http://www.ti.com/energy">www.ti.com/energy</a>
Industrial	<a href="http://www.ti.com/industrial">www.ti.com/industrial</a>
Medical	<a href="http://www.ti.com/medical">www.ti.com/medical</a>
Security	<a href="http://www.ti.com/security">www.ti.com/security</a>
Space, Avionics and Defense	<a href="http://www.ti.com/space-avionics-defense">www.ti.com/space-avionics-defense</a>
Video and Imaging	<a href="http://www.ti.com/video">www.ti.com/video</a>

### TI E2E Community

[e2e.ti.com](http://e2e.ti.com)