

POWER MANAGEMENT

Description

The EZ158X family of high performance positive voltage regulators are designed for use in applications requiring very low dropout voltage at up to 7, 5, 3 and 1.5 amps. Capable of supplying up to 2.8V on boards where both 5V and 3.3V supplies are available, the superior dropout characteristics of the EZ158X result in reduced heat dissipation compared to regular LDOs. This allows for heatsink size reduction or elimination. Additionally, the EZ158X provides excellent regulation over variations in line, load and temperature. Remote sense operation allows compensating for trace, connector and other resistive losses.

Outstanding features include very low dropout performance at rated current, fast transient response, remote sense, internal current limiting, thermal shutdown and safe operating area protection of the output device. The EZ158X is a five terminal adjustable or fixed 2.5V voltage regulator available in the popular 5 pin TO-220 and TO-263 plastic packages.

Features

- ◆ 540mV dropout @ 7A in dual supply mode (EZ1580)
- ◆ Remote sense operation
- ◆ Fast transient response
- ◆ 0.5% initial accuracy
- ◆ Line regulation typically 0.08%
- ◆ Load regulation typically 0.08%
- ◆ 5 Pin TO-220 and TO-263 packages

Applications

- ◆ Microprocessor supplies
- ◆ Split plane microprocessor supplies
- ◆ Advanced graphics cards
- ◆ Sound cards
- ◆ Low voltage logic supplies
- ◆ Switching power supply post regulation

Typical Application Circuits

Adjustable Output Parts⁽³⁾

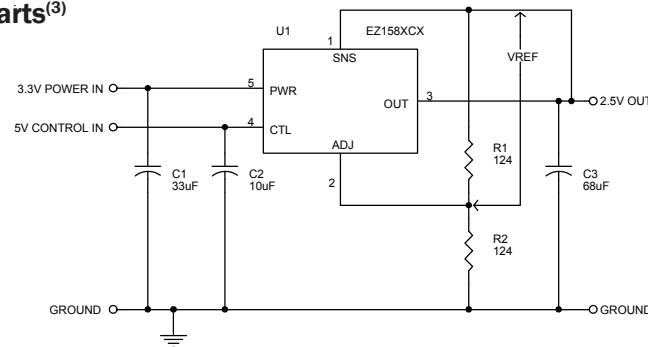

$$V_{OUT} = V_{REF} \left(1 + \frac{R2}{R1} \right) + I_{ADJ} \cdot R2$$

Fixed Output Parts

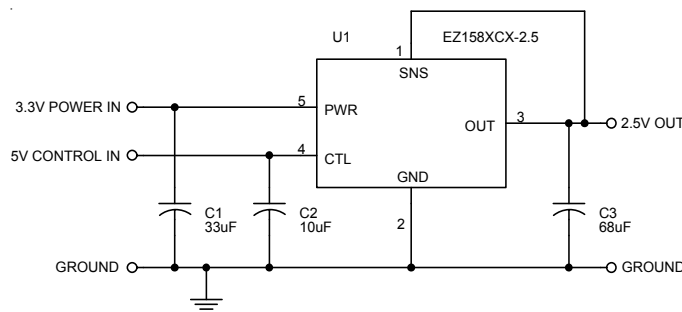

Notes:

- (1) Capacitor values are for reference only. Good quality, low ESR tantalum or aluminum electrolytic capacitors should be used. Increasing the value of the output capacitor will improve the overall transient response.
- (2) If the same voltage is input to both PWR and CTL, then the dropout voltage will become 1.3V maximum.
- (3) A small (~0.033µF) capacitor can be used to bypass the ADJ pin to improve transient response, if needed.

POWER MANAGEMENT
Absolute Maximum Ratings

Parameter	Symbol	Maximum	Units
Power Input Voltage	V_{PWR}	7	V
Control Input Voltage	V_{CTL}	13.2	V
Power Dissipation	P_D	Internally Limited	W
Thermal Resistance Junction to Ambient EZ158X TO-220 EZ158X TO-263	θ_{JA}	50 60	°C/W
Thermal Resistance Junction to Case EZ1580/1 (TO-220 & TO-263) EZ1582/3 (TO-220 & TO-263)	θ_{JC}	2 3	°C/W
Operating Junction Temperature Range	T_J	0 to +125	°C
Storage Temperature Range	T_{STG}	-65 to +150	°C
Lead Temperature (Soldering) 10 Sec.	T_{LEAD}	300	°C
ESD Rating (Human Body Model)	ESD	2	kV

Electrical Characteristics⁽⁷⁾

Unless specified: $V_{OUT} = V_{SNS}$, $V_{ADJ} = 0V$, $C_{CTL} = C_{PWR} = C_{OUT} = 10\mu F$. Values in **bold** apply over full operating temperature range.

Parameter	Symbol	Test Conditions	Min	Typ	Max	Units
Reference Voltage ⁽¹⁾ (Adj. Voltage Versions)	V_{REF}	$V_{PWR} = 2.05V$, $V_{CTL} = 4.5V$, $I_{OUT} = 10mA$	1.237	1.250	1.263	V
		$V_{PWR} = 2.05V$, $V_{CTL} = 4.5V$, $10mA < I_{OUT} < I_{RATED}$	1.231		1.269	
Output Voltage ⁽¹⁾ (2.5V Version)	V_{OUT}	$V_{PWR} = 3.3V$, $V_{CTL} = 4.5V$, $I_{OUT} = 10mA$	-1	V_{OUT}	+1	%
		$V_{PWR} = 3.3V$, $V_{CTL} = 4.5V$, $10mA < I_{OUT} < I_{RATED}$	-1.5		+1.5	
Line Regulation ⁽¹⁾	$REG_{(LINE)}$	$V_{PWR} = (V_{OUT} + 0.8V)$ to 5.5V, $V_{CTL} = 4.5V$ to 12V, $I_{OUT} = 10mA$		1.0	3.0	mV
Load Regulation ⁽¹⁾	$REG_{(LOAD)}$	$V_{PWR} = V_{OUT} + 0.8V$, $V_{CTL} = 4.5V$, $I_{OUT} = 10mA$ to I_{RATED}		1.0	5.0	mV
V_{PWR} Dropout Voltage ⁽¹⁾⁽²⁾ EZ1581, EZ1582, EZ1583	$V_{PWR} - V_{OUT}$	$V_{CTL} = 4.75V$, $I_O = I_{RATED}$		0.40 0.50	0.50 0.60	V
V_{PWR} Dropout Voltage ⁽¹⁾⁽²⁾ EZ1580		$V_{CTL} = 4.75V$, $I_O = I_{RATED}$		0.54 0.70	0.62 0.80	V

POWER MANAGEMENT
Electrical Characteristics (Cont.)⁽⁷⁾

Unless specified: $V_{OUT} = V_{SNS}$, $V_{ADJ} = 0V$, $C_{CTL} = C_{PWR} = C_{OUT} = 10\mu F$. Values in **bold** apply over full operating temperature range.

Parameter	Symbol	Test Conditions	Min	Typ	Max	Units
Control Pin Current ⁽³⁾	I_{CTL}	$V_{PWR} = V_{OUT} + 0.8V$, $V_{CTL} = 4.5V$, $I_{OUT} = I_{RATED}$		6	120	mA
EZ1583				30	120	
EZ1582				33	120	
EZ1581				60	120	
EZ1580						
Adjust Pin Current	I_{ADJ}	$V_{PWR} = 2.05V$, $V_{CTL} = 4.5V$, $I_{OUT} = 10mA$		50	120	μA
Minimum Load Current ⁽⁴⁾	$I_{OUT(MIN)}$	$V_{PWR} = V_{OUT} + 0.8V$, $V_{CTL} = 5V$		5	10	mA
Current Limit	I_{CL}	$V_{PWR} = V_{OUT} + 0.8V$, $V_{CTL} = 4.5V$, $\Delta V_{OUT} = 100mV$		1.6		A
EZ1583				3.1		
EZ1582				5.1		
EZ1581				7.1		
EZ1580						
Ripple Rejection Ratio ⁽⁵⁾	R_A	$V_{PWR} = V_{CTL} = 5V$, $I_O = I_{RATED}$	60	80		dB
Thermal Regulation ⁽⁶⁾	$REG_{(THERMAL)}$			0.002	0.02	%/W

NOTES:

- (1) Low duty cycle pulse testing with Kelvin connections required.
- (2) Minimum input to output voltage differential required to maintain 1% regulation.
- (3) Current used to drive the output section.
- (4) Required to maintain regulation. Resistor divider R1, R2 is usually utilized for minimum load current.
- (5) $V_{RIPPLE} = 1V_{PK-PK}$, 120Hz.
- (6) 30ms.
- (7) $I_{RATED} = 1.5A$ for EZ1583, 3A for EZ1582, 5A for EZ1581 and 7A for EZ1580.

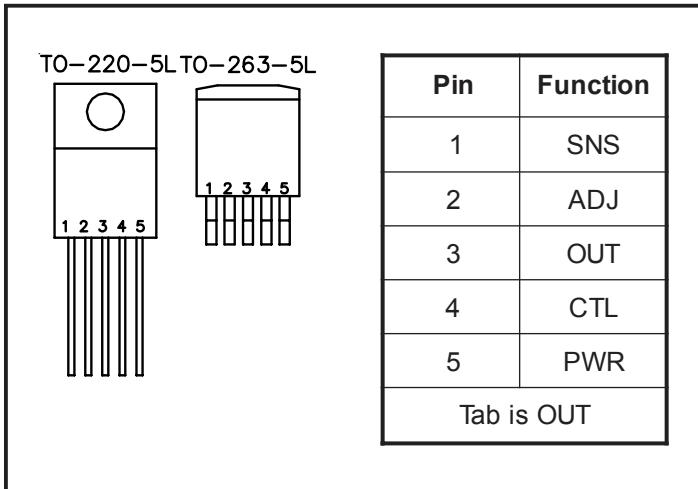
POWER MANAGEMENT
Pin Configurations

Ordering Information

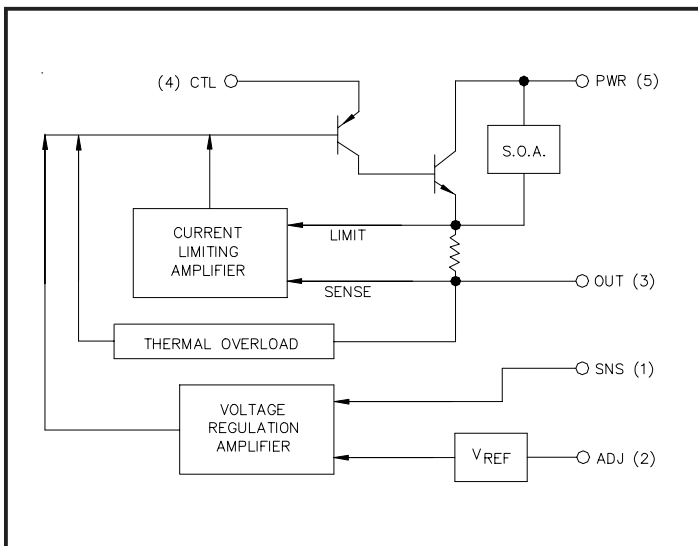
Device ⁽¹⁾	Package	I _{OUT} (A)
EZ1580CT-X.X	TO-220, 5-pin ⁽²⁾	7
EZ1581CT-X.X		5
EZ1582CT-X.X		3
EZ1583CT-X.X		2.5
EZ1580CM-X.X.TR	TO-263, 5-pin ⁽³⁾	7
EZ1581CM-X.X.TR		5
EZ1582CM-X.X.TR		3
EZ1583CM-X.X.TR		2.5
EZ1583CMTRT ⁽⁴⁾		-
EZ158xCM-X.XTRT ⁽⁴⁾		-

Block Diagram

Pin Descriptions

Pin #	Symbol	Pin Name	Pin Function
1	SNS	SENSE	This pin is the positive side of the reference voltage for this device. With this pin it is possible to Kelvin sense the output voltage at the load.
2	ADJ	ADJUST	This pin is the negative side of the reference voltage for this device. Transient response can be improved by adding a small bypass capacitor from the adjust pin to ground.
3	OUT	OUTPUT	This is the power output of the device. This pin is electrically connected to the tab.
4	CTL	CONTROL	This pin is the supply pin for the control circuitry for the device. The current flow into this pin will be approximately 1% of the output current. For the device to regulate, the voltage on this pin must be between 1.0V and 1.3V greater than the output voltage.
5	PWR	POWER	This is the collector input to the power device of the EZ1583. The output load current is supplied through this pin. For the device to regulate, the voltage on this pin must be between 0.1V and 0.8V greater than the output voltage, depending upon load current.

Notes:

- (1) Where -X.X denotes voltage options. Available voltage is: 2.5V. Leave blank for adjustable version (1.3 to 5.7V).
- (2) Only available in tube packaging. A tube contains 50 devices.
- (3) Only available in tape and reel packaging. A reel contains 800 devices.
- (4) This product is fully WEEE and RoHS compliant. Where x = 0; 1; 2 or 3. X.X denotes voltage options.

POWER MANAGEMENT

Applications Information

The EZ158X is a low dropout regulator designed to power low voltage microcontrollers, graphics ICs, sound cards etc.

The dropout voltage is minimized by utilizing a separate input voltage, V_{CTL} , which should exceed V_{OUT} by at least 1.3V. The 2.5V (for example) power for the load can be derived from a 3.3V system supply. Since the efficiency of a linear regulator is the ratio of the output to the input voltage, heat dissipation is reduced by using a 3.3V input (versus a 5V one), thereby lowering heatsink and cooling

fan costs. For lower current applications, the heatsink might be eliminated altogether. For a load of 7A at 2.5V, the regulator would dissipate 17.5W when converting from 5V, but only 5.6W from a 3.3V input.

Remote Kelvin sensing of the output voltage can be achieved by connecting the sense pin to the output at the load. Remote sensing will reduce errors associated with resistive trace losses between regulator and processor.

Outline Drawing - TO-220-5

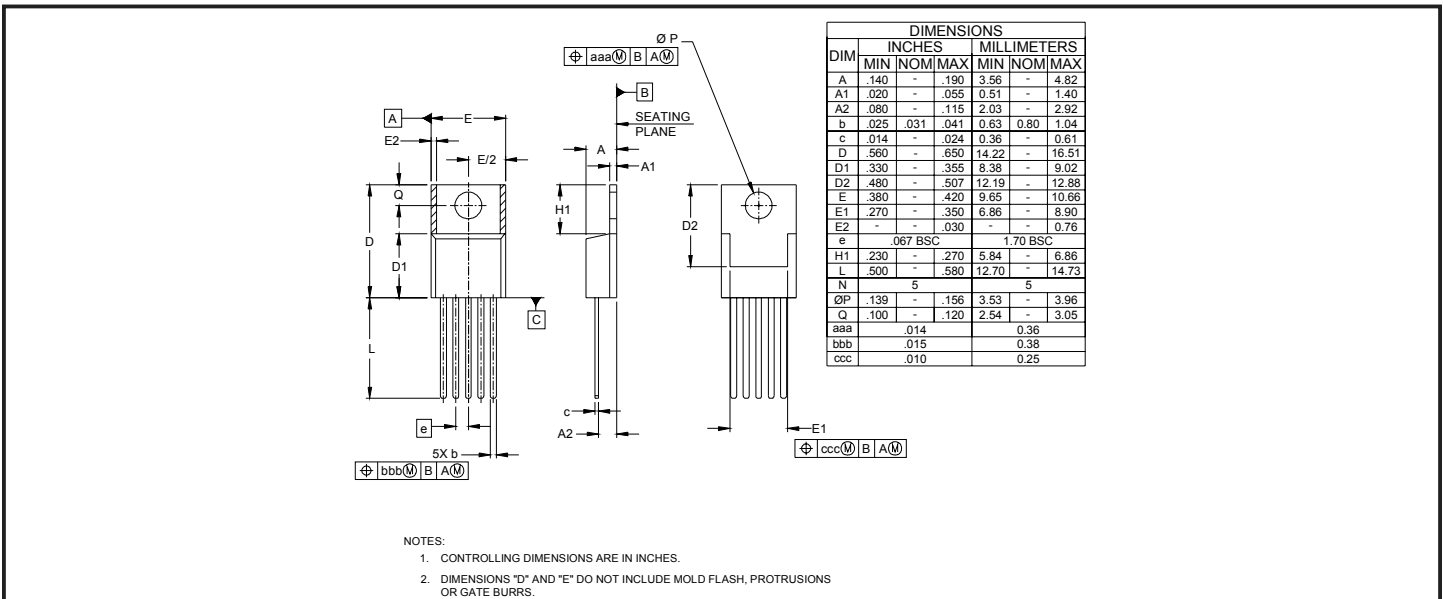

Outline Drawing - TO-263-5

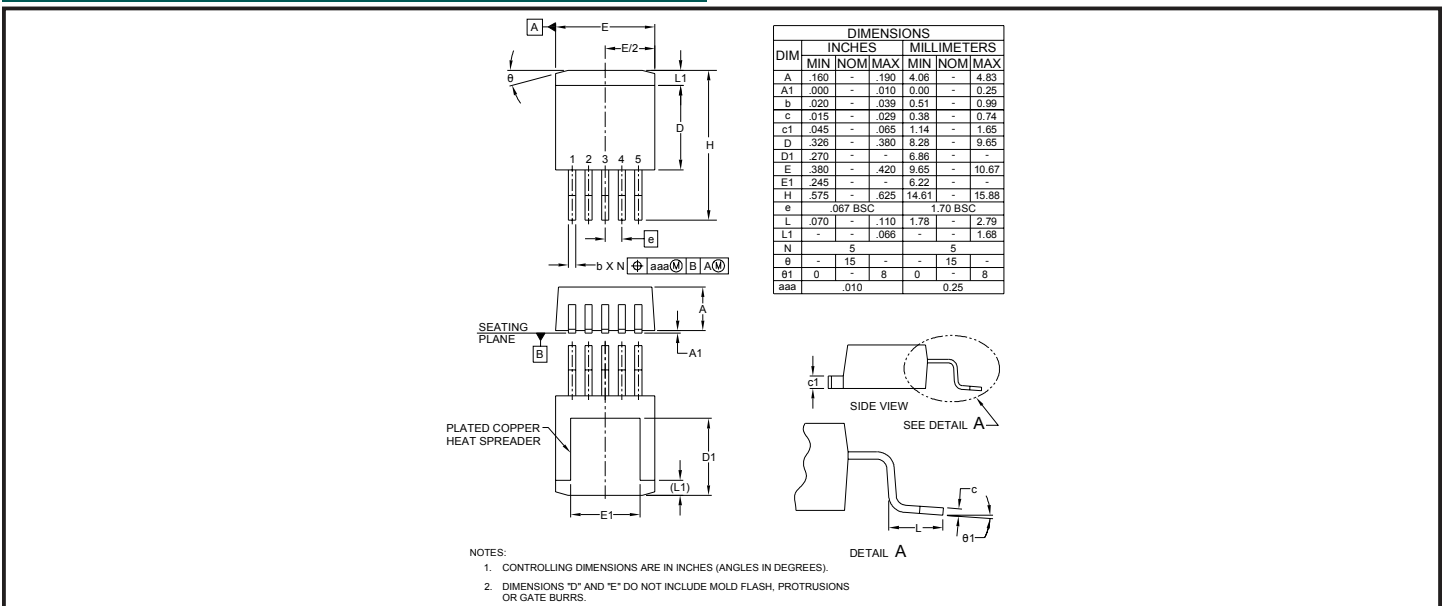

POWER MANAGEMENT

Minimum Land Pattern - TO-263-5

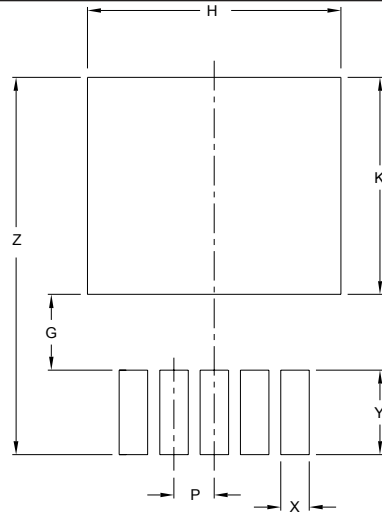

DIMENSIONS		
DIM	INCHES	MILLIMETERS
G	.125	3.18
H	.420	10.67
K	.360	9.14
P	.067	1.70
X	.042	1.07
Y	.140	3.56
Z	.625	15.88

NOTES:

1. CONTROLLING DIMENSIONS ARE IN INCHES (ANGLES IN DEGREES).
2. THIS LAND PATTERN IS FOR REFERENCE PURPOSES ONLY
CONSULT YOUR MANUFACTURING GROUP TO ENSURE YOUR
COMPANY'S MANUFACTURING GUIDELINES ARE MET.

Contact Information

Semtech Corporation
Power Management Products Division
200 Flynn Road, Camarillo, CA 93012
Phone: (805)498-2111 FAX (805)498-3804