



HEATSINK KIT for DC/DC CONVERTERS

FEATURES:

- * Constructed of aluminum AL6063 for optimum heat transfer
- * Designed specifically for DC/DC Converters and other baseplate packages
- * Finished with black anodize plating
- * Mounting hardware and thermal pad are available

DC/DC PACKAGE	FIN STYLE	HEATSINK HEIGHT (mm)	PART NUMBER			THERMAL RESISTANCE (C/W)				
			HEATSINK	THERMAL PAD	MOUNTING HARDWARE	NATURAL CONVECTION	100 LFM	200 LFM	300 LFM	400 LFM
SB 1"x1"	Cross Cut	10.0	SBC100 (K-C087)	N/A ^7	CLIP HC01	12.5	--	--	--	--
B 2"x1"	Cross Cut	10.0	BC100 (K-C088)	N/A ^7	CLIP HC01	10.2	--	--	--	--
LB 2.05"x1.2"	Transverse	12.7	LBT127 (M-C655)	PL01	K258W (NOTES 5)	8.99	3.29	2.73	2.40	2.10
Quarter Brick	Longitudinal	12.7	QBL127 (M-C448)	PQ01	K308W (NOTES 5)	5.61	4.01	3.39	2.86	2.49
	Transverse	21	QBT210 (M-C421)			4.78	2.44	2.06	1.76	1.58
Half Brick	Longitudinal	21	HBL210 (M-C308)	PH01	K310W (NOTES 5)	3.9	1.74	1.33	1.12	0.97
	Transverse	12.7	HBT127 (M-C091)			4.7	2.89	2.3	1.88	1.59
	Transverse	25.4	HBT254 (M-C092)			3.0	1.44	1.17	1.04	0.95
Full Brick	Longitudinal	25.4	FBL254 (M-B012)	PF01	K320W (NOTES 5)	2.4	1.76	1.17	1.0	0.83
	Longitudinal	25.4	FBL254T ^1 (M-C997)		K320N (NOTES 5)	2.4	1.76	1.17	1.0	0.83

NOTES:

1. With threaded mounting hole
2. Example Part Numbers:
 QBL127: Quarter Brick Heatsink (12.7mm High), plate fin (longitudinal)
 FBL254PF01: Full Brick Heatsink (25.4mm High), plate fin (longitudinal) with thermal interface pad
 HBT127PH01K308W: Half Brick Heatsink (12.7mm High), plate fin (transverse) with thermal interface pad and 4 pieces of M3 x 8mm screws & spring washers
 HBL210K308W: Half Brick Heatsink (21.0mm High), plate fin (longitudinal) with 4 pieces of M3 x 8mm screws & spring washers
3. Thermal data provided are for reference only. Actual cooling performance may vary by application.
4. Specifications are subject to change without notice.
5. K258W: Screw set M2.5*8mm screw & lock washer x 2pcs K308W : Screw set M3*8mm screw with spring washer x 4pcs
 K310W: Screw set M3*10mm screw with spring washer x 4pcs K320W : Screw set M3*20mm screw & spring washer x 4pcs
 K320N: Screw set M3*20mm screw & lock screw nut x 4pcs
6. For volume orders, converters will be supplied with heat-sink already mounted. Separate heatsinks are only available for prototypes and small quantity orders.
7. Applying proper thermal paste is recommended.



SB 1"x1" CASE HEATSINK KIT

Cross Cut Heat Sink: SBC100 (K-C087)

All Dimensions in mm

Rca: 12.5°C/W (typ.), at natural convection

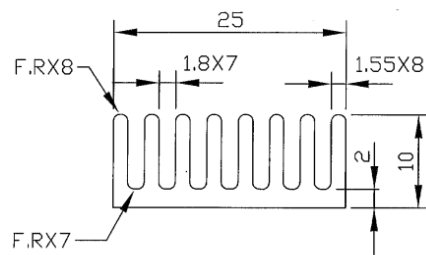
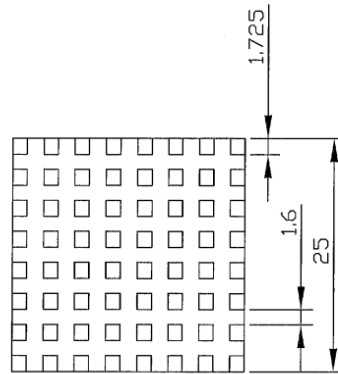

Assembly:

Heat Sink: SBC100

Clip: HC01

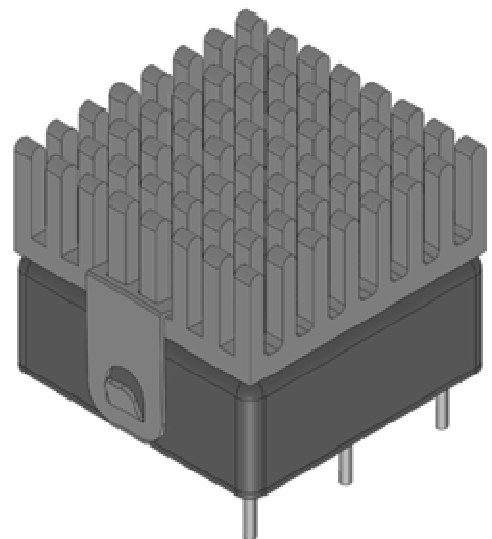



B 2"x1" CASE HEATSINK KIT

Cross Cut Heat Sink: BC100 (K-C088)

All Dimensions in mm

Rca: 10.2°C/W (typ.), at natural convection

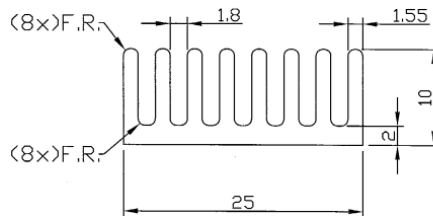
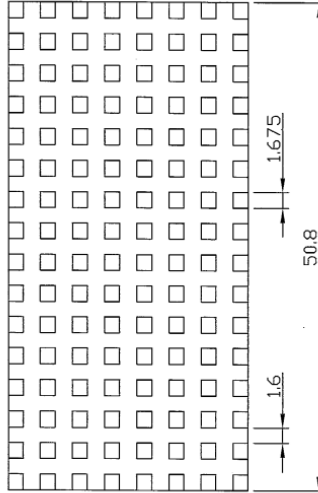

Assembly:

Heat Sink: BC100

Clip: HC01

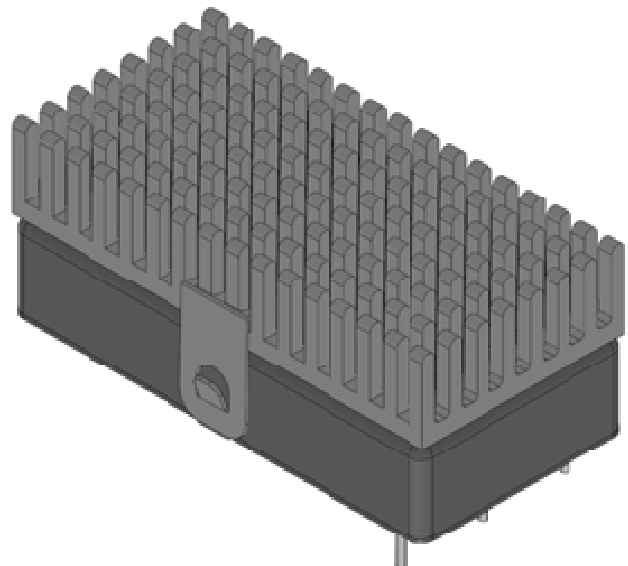



LB 2.05"x1.2" CASE HEATSINK KIT

Heat Sink: LBT127 (M-C655) Transverse Fins

All Dimensions in mm

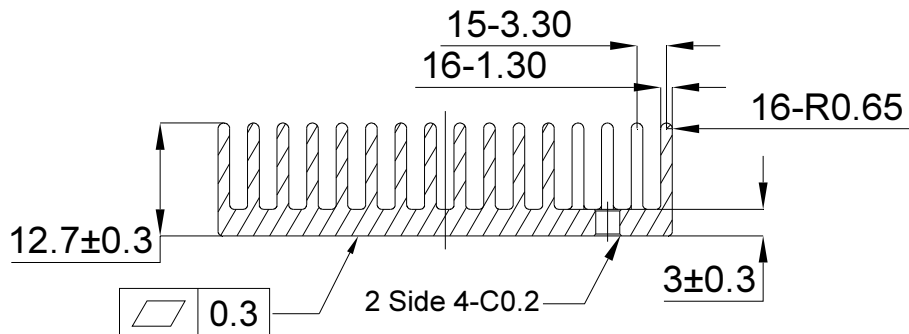
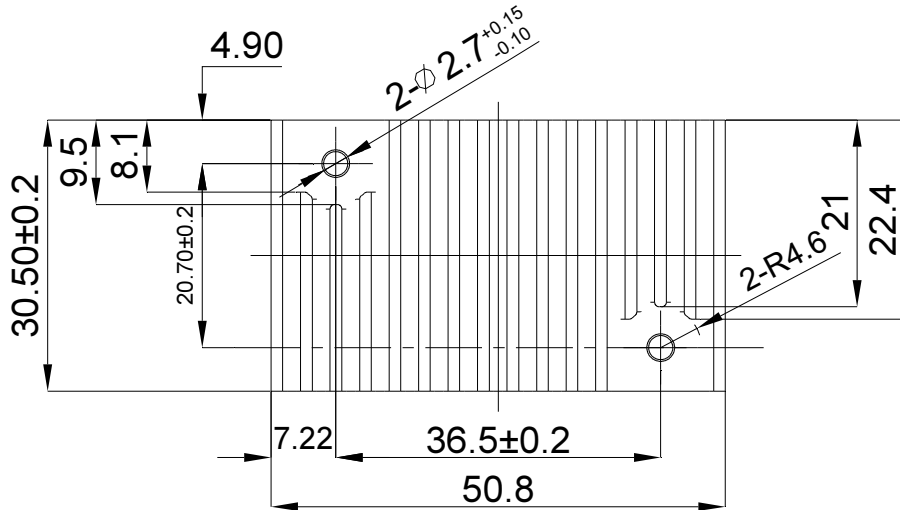

Rca: 8.99°C/W (typ.), at natural convection
 3.29°C/W (typ.), at 100LFM
 2.73°C/W (typ.), at 200LFM
 2.40°C/W (typ.), at 300LFM
 2.10°C/W (typ.), at 400LFM

Thermal Pad: PL01 29.5*49.8*0.25mm

Screw Set: K258W M2.5*8mm+Lock Washer



QB CASE HEATSINK KIT

Heat Sink: QBT210 (M-C421) Transverse Fins

All Dimensions in mm

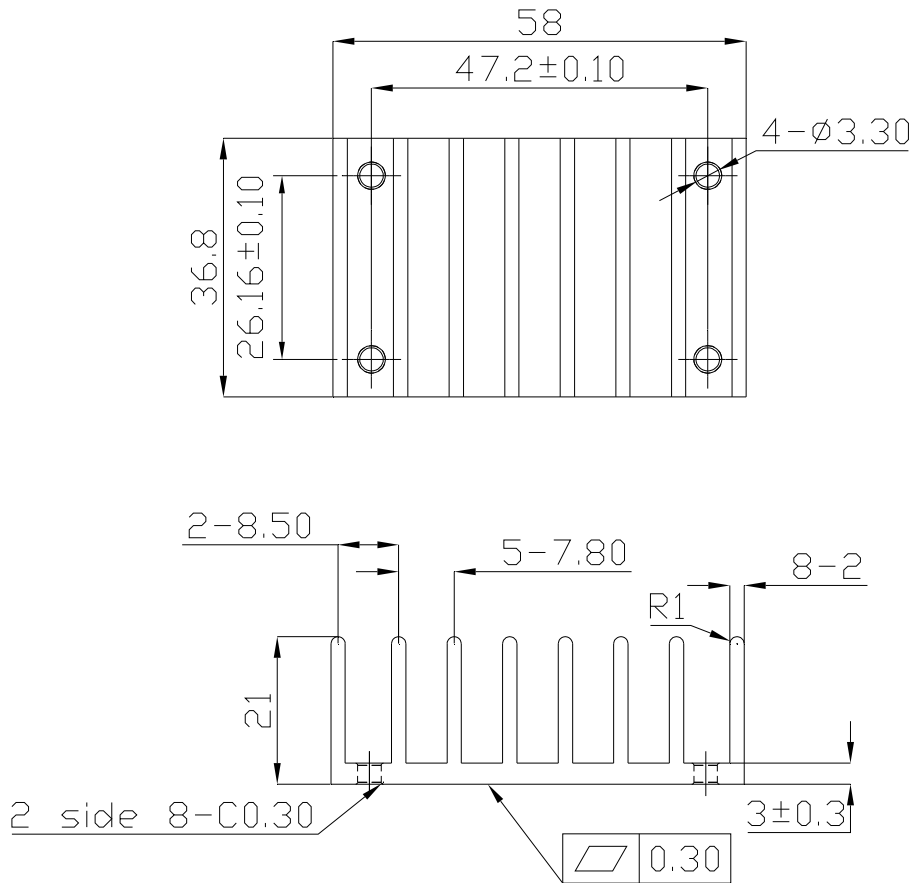

- Rca: 4.78°C/W (typ.), at natural convection
- 2.44°C/W (typ.), at 100LFM
- 2.06°C/W (typ.), at 200LFM
- 1.76°C/W (typ.), at 300LFM
- 1.58°C/W (typ.), at 400LFM

Thermal Pad: PQ01 35.8*56.9*0.25 mm

Screw Set: K308W SMP+SW M3*8mm



QB CASE HEATSINK KIT

Heat Sink: QBL127 (M-C448) Longitudinal Fins

All Dimensions in mm

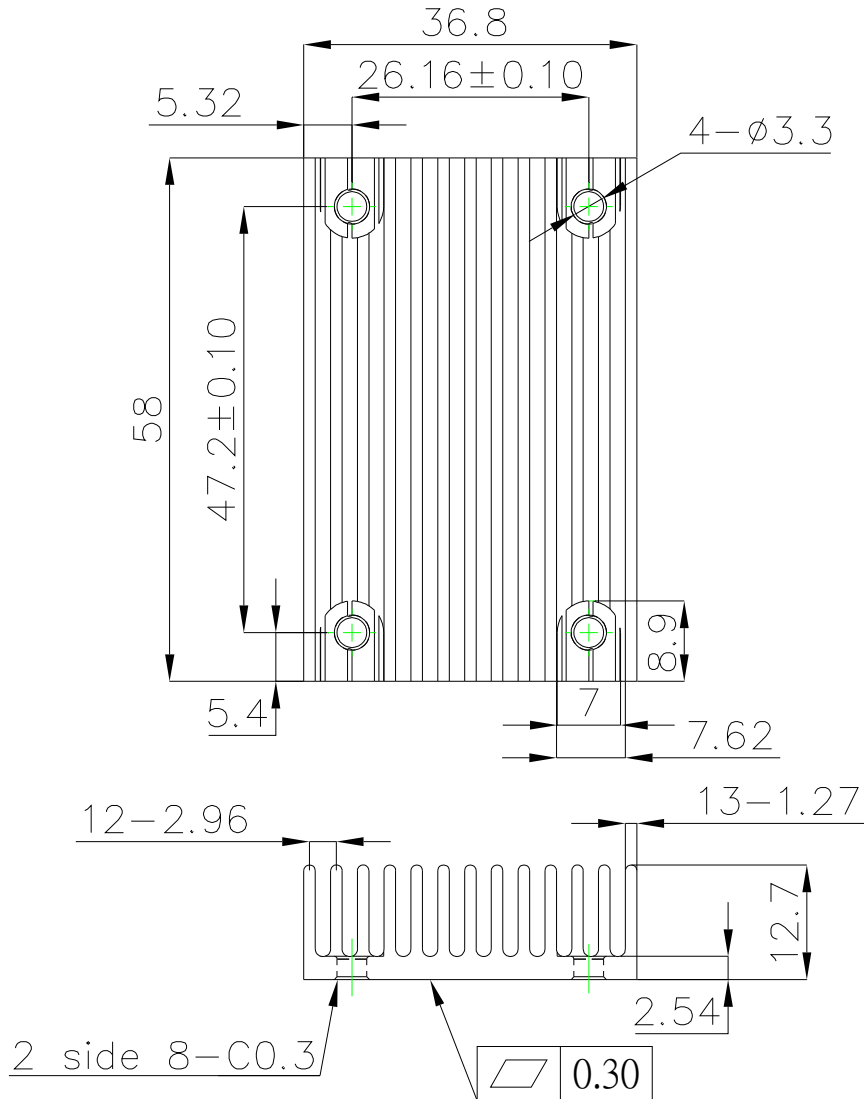

- Rca: 5.61°C/W (typ.), at natural convection
- 4.01°C/W (typ.), at 100LFM
- 3.39°C/W (typ.), at 200LFM
- 2.86°C/W (typ.), at 300LFM
- 2.49°C/W (typ.), at 400LFM

Thermal Pad: PQ01 35.8*56.9*0.25 mm

Screw Set: K308W SMP+SW M3*8mm



HB CASE HEATSINK

Heat Sink: HBL210 (M-C308) Longitudinal Fins

All Dimensions in mm

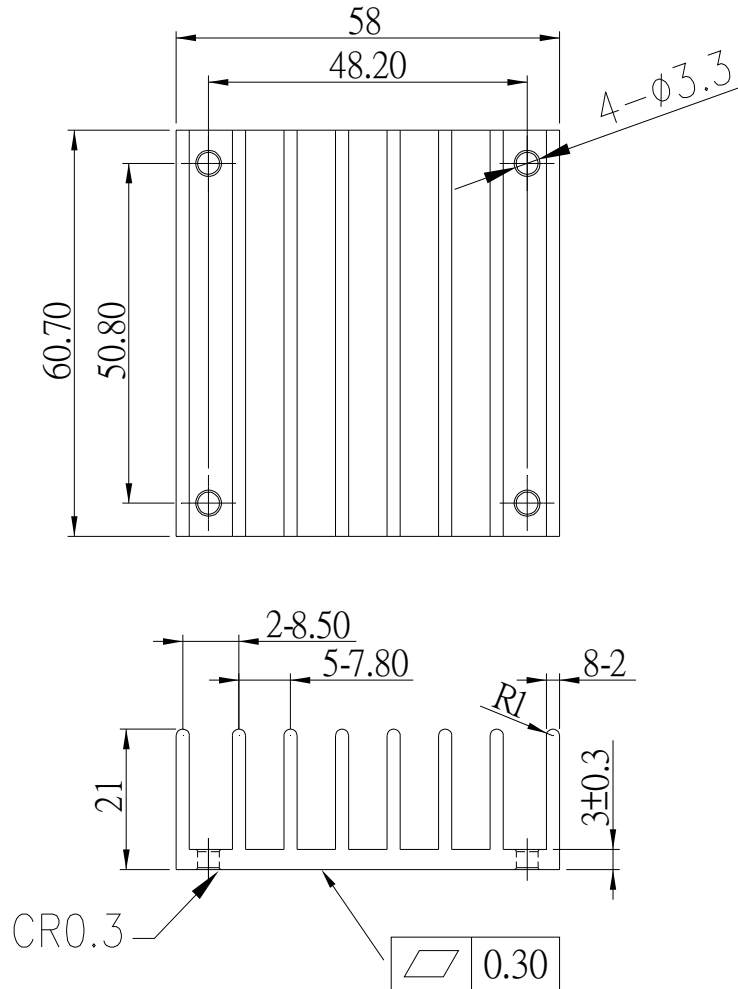

Rca: 3.9°C/W (typ.), at natural convection

1.74°C/W (typ.), at 100LFM

1.33°C/W (typ.), at 200LFM

1.12°C/W (typ.), at 300LFM

0.97 °C/W (typ.), at 400LFM



HB CASE HEATSINK

Heat Sink: HBT127 (M-C091) Transverse Fins

All Dimensions in mm

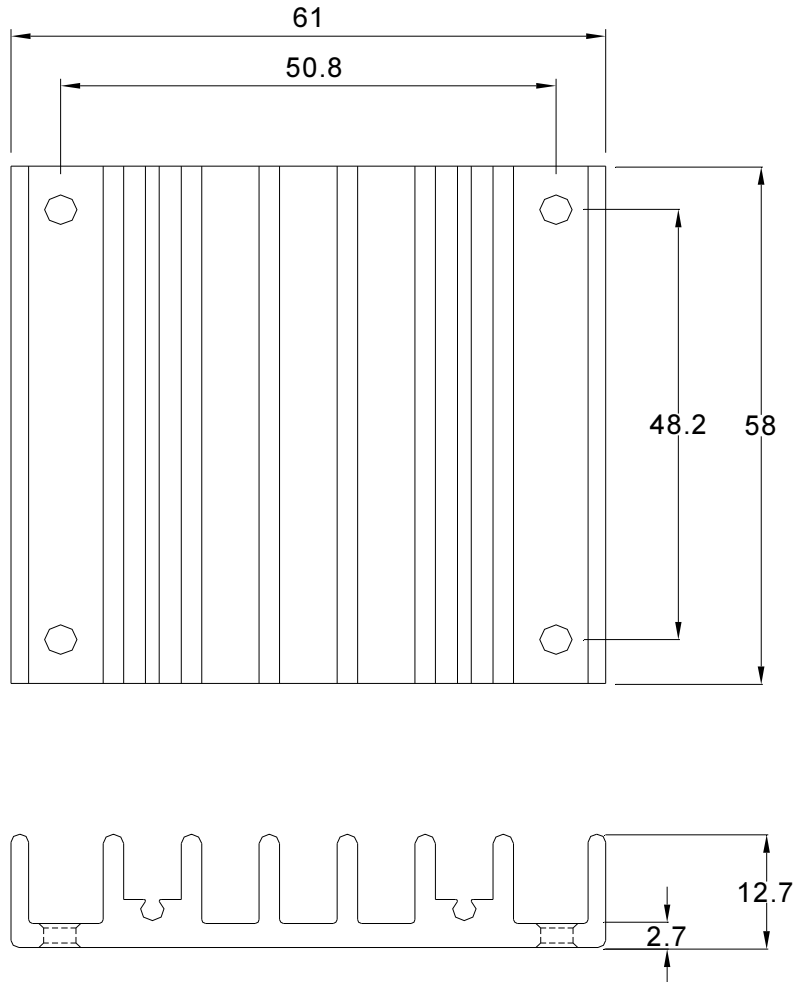

M-C091

Rca: 4.7°C/W (typ.), at natural convection

2.89°C/W (typ.), at 100LFM

2.30°C/W (typ.), at 200LFM

1.88°C/W (typ.), at 300LFM

1.59°C/W (typ.), at 400LFM

章 節	HS-1
頁 次	1-8



HB CASE HEATSINK

Heat Sink: HBT127 (M-C092) Transverse Fins

All Dimensions in mm

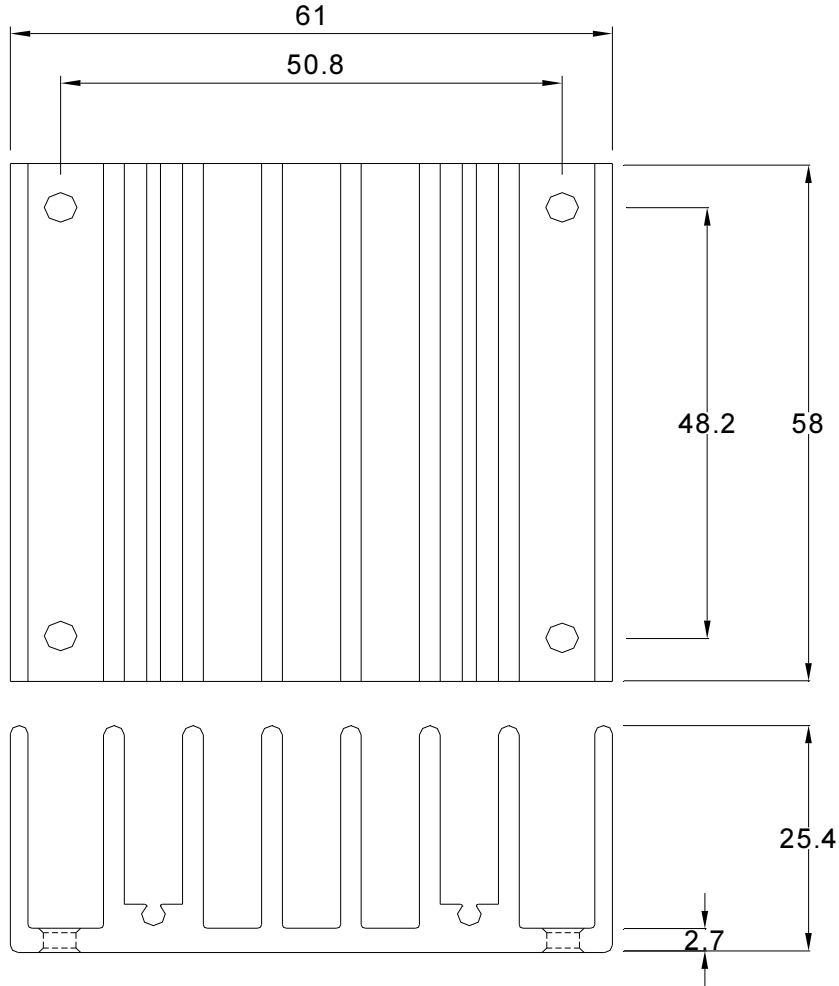

M-C092

- Rca: 3°C/W (typ.), at natural convection
- 1.44°C/W (typ.), at 100LFM
- 1.17°C/W (typ.), at 200LFM
- 1.04°C/W (typ.), at 300LFM
- 0.95°C/W (typ.), at 400LFM



HB CASE HEATSINK Assembly

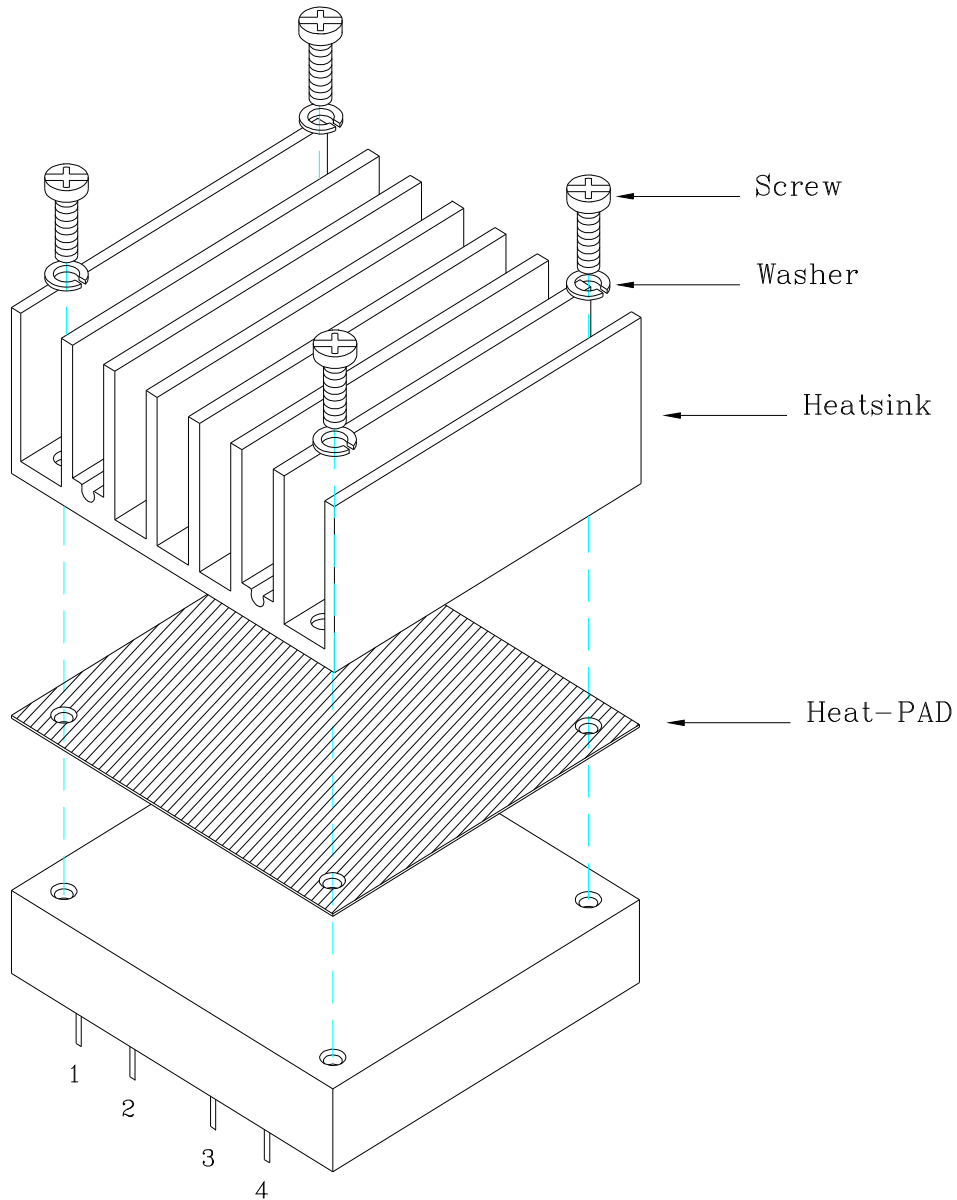

Heat Sink: HBL210 (M-C308)

HBT127 (M-C091)

HBT254 (M-C092)

Thermal Pad: PH01 56.9*60*0.25 mm

Screw Set: K308W SMP+SW M3*8mm



FB CASE HEATSINK

Heat Sink: FBL254 (M-B012) Longitudinal Fins

Clear Mounting Inserts $\Phi 3.3\text{mm}$ Through

All Dimensions in mm

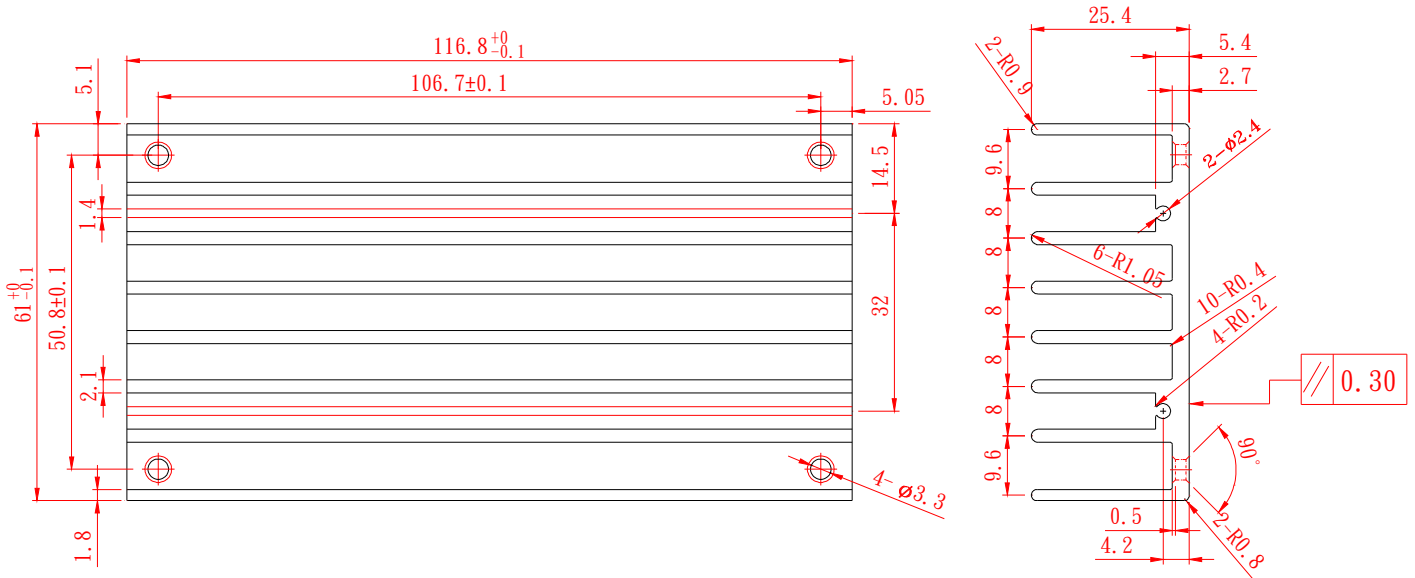

Heat Sink: FBL254T(M-C997) Longitudinal Fins

** Mounting Inserts M3*0.5 Through**

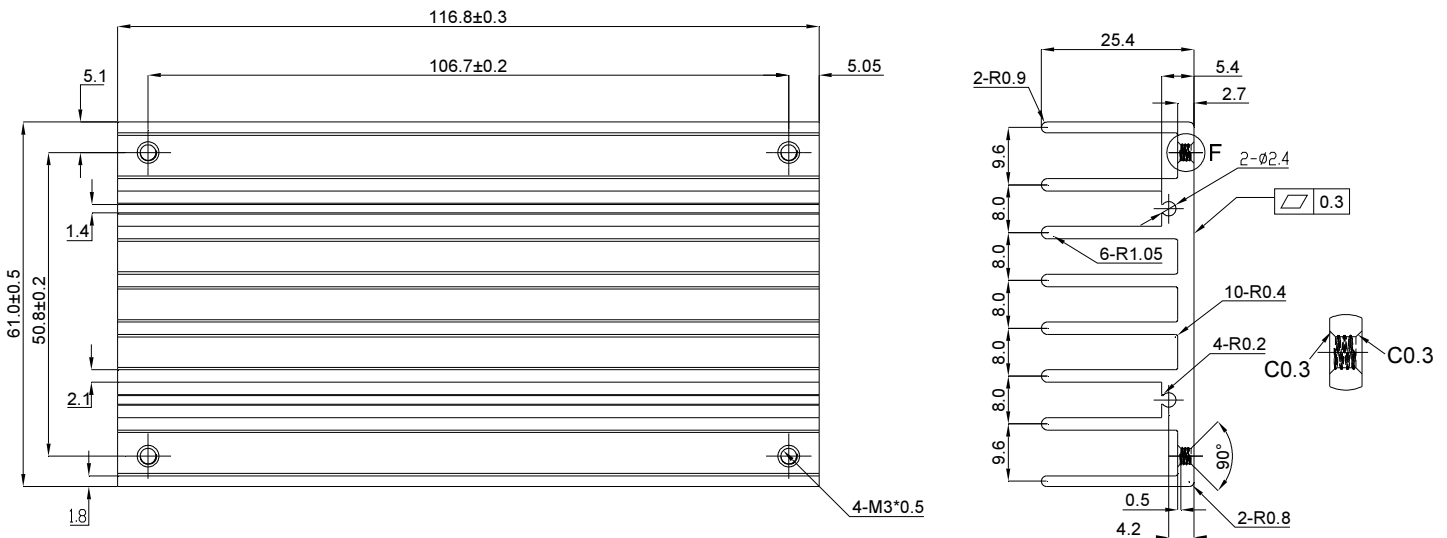

Rca: 2.4°C/W (typ.), at natural convection

1.76°C/W (typ.), at 100LFM

1.17°C/W (typ.), at 200LFM

1.00°C/W (typ.), at 300LFM

0.83°C/W (typ.), at 400LFM



FB CASE HEATSINK Assembly

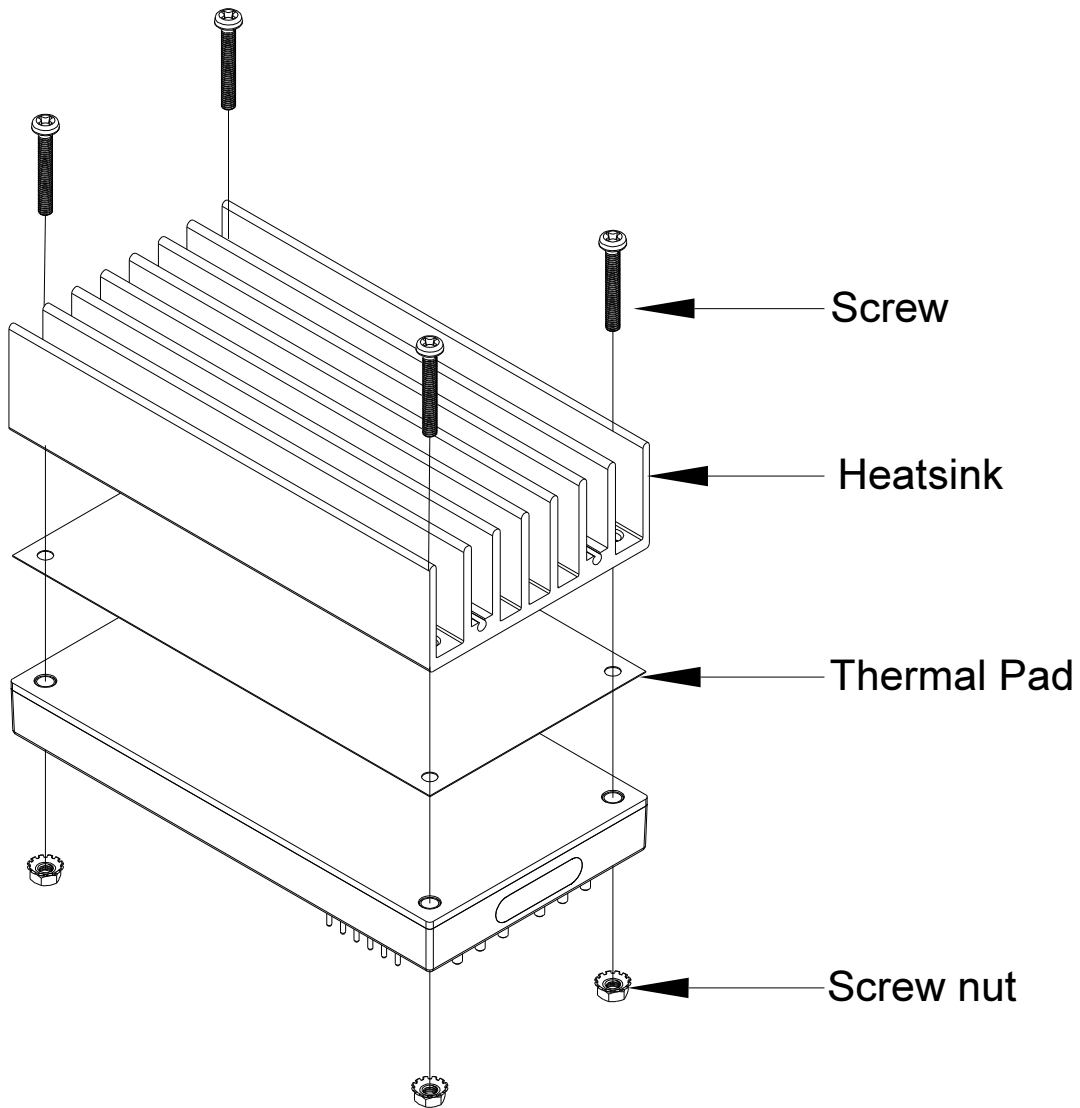

Heat Sink: FBL254 (M-B012)

Thermal Pad: PF01 60*115.8*0.25mm

Screw Set: K320N M3*20mm + Nut NH+WOM3*P0.5N



FB CASE HEATSINK Assembly

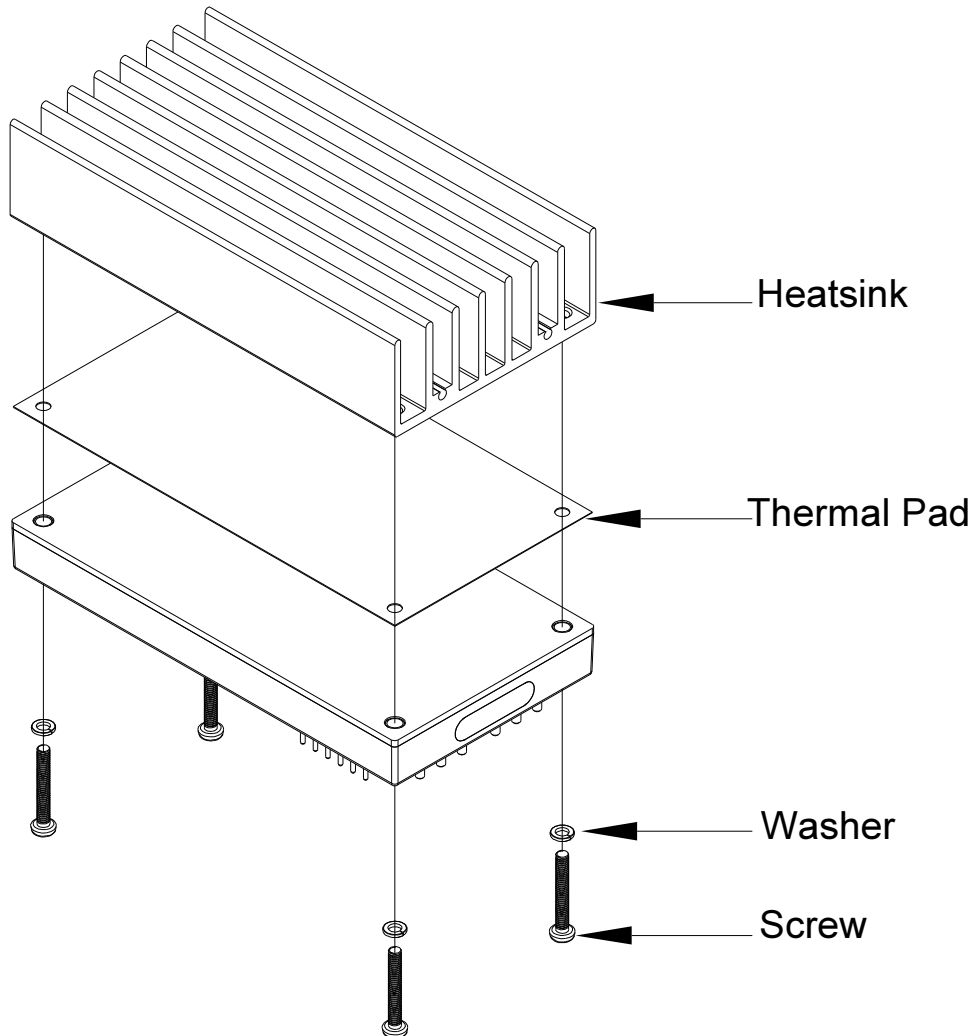

Heat Sink: FBL254T (M-C997)

Thermal Pad: PF01 60*115.8*0.25

Screw Set: K320W M3*20mm+Washer WS3.2N