

CCS803

Ultra-Low Power Gas Sensor for Ethanol Detection

General Description

ams micro-hotplate technology provides a unique silicon platform for the CCS80x range of Metal Oxide (MOX) gas sensors. These devices enable sensor miniaturisation, have ultra-low power consumption and provide fast response times due to the ability to heat the micro-hotplate very quickly.

The micro-hotplates are fabricated using a robust silicon dioxide membrane and include an embedded tungsten heating element to heat the MOX based sensing material. The MOX sensing material can be heated up to 500°C to allow the electrical resistance of the MOX sensor to be monitored to detect the target gas. By exploiting the fast heater cycling times, temperature modulation techniques can be used to reduce the device power consumption and implement advanced gas sensing methods.

Software libraries containing proprietary algorithms and an example Android app for Alcohol breathalyser use case are available.

Product Overview

The CCS803 is an ultra-low power MOX gas sensor for Ethanol detection.

For CCS803 a supply voltage (V_H) is provided to the integrated micro-heater and the gas concentration can be correlated to the change in resistance of the MOX sensing layer (R_S).

V_H can be set using a low-dropout (LDO) regulator or operated in pulsed PWM mode to reduce power consumption. The sensor resistance (R_S) is typically determined using a series load resistor (R_L), a reference voltage (V_{REF}), and an output voltage (V_{OUT}) read by an Analogue-to-Digital Converter (ADC). The reference voltage (V_{REF}) must only be enabled during the sensor reading.

CCS803 is supported in a compact 2mm x 3mm x 1mm DFN (Dual Flat No lead) package as standard.

[Ordering Information](#) and [Content Guide](#) appear at end of datasheet.

Key Benefits & Features

The benefits and features of CCS803, Ultra-Low Power Gas Sensor for Ethanol Detection are listed below:

Figure 1:
Added Value of Using CCS803 Sensor

Benefits	Features
<ul style="list-style-type: none"> Extended battery life in portable applications 	<ul style="list-style-type: none"> Low power consumption
<ul style="list-style-type: none"> High sensitivity to Ethanol 	<ul style="list-style-type: none"> Reduced cross-sensitivity
<ul style="list-style-type: none"> Fast heating time < 15ms 	<ul style="list-style-type: none"> Quick response to target gas
<ul style="list-style-type: none"> Suitable for small form factor designs 	<ul style="list-style-type: none"> Compact 2mm x 3mm x 1mm package

Applications

CCS803 can be used to detect Ethanol on breath for Alcohol breath analysis in accessories and consumer devices.

Figure 2:
Recommended Sensor Configuration

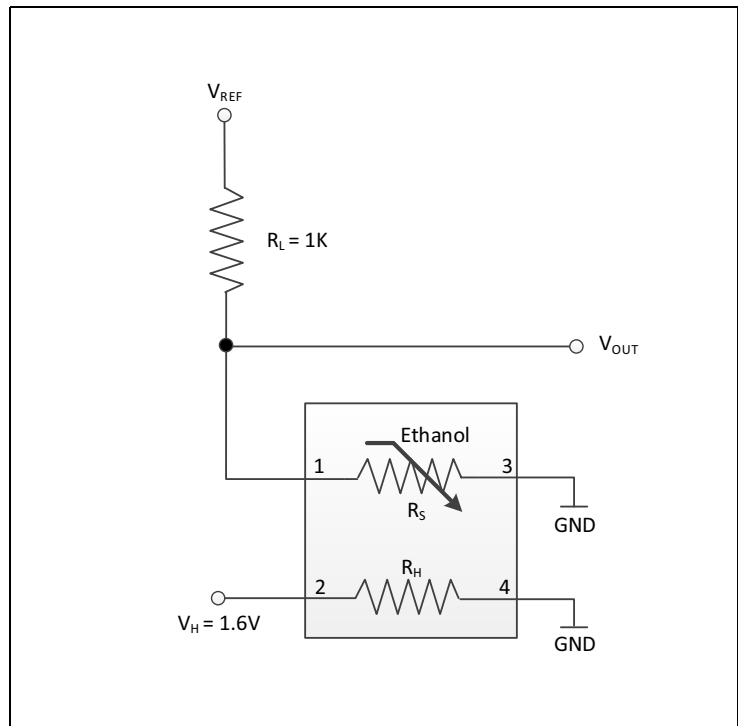

Pin Assignment

Figure 3:
Pin Diagram

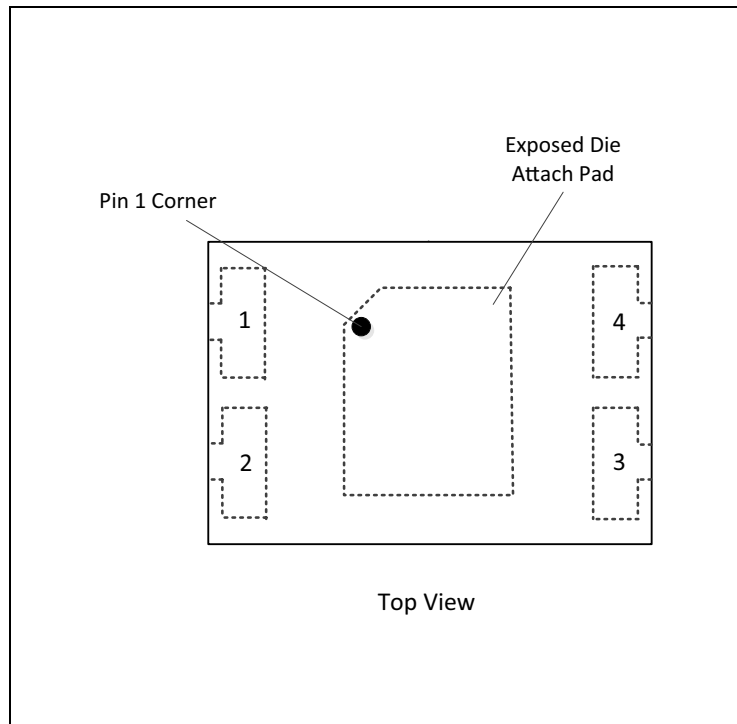

Figure 4:
Pin Description

Pin Number	Pin Name	Description
1	Sensor+	Sensor output (V_{OUT})
2	Heater+	Heater Input (V_H)
3	Sensor-	Connect to Ground or 0V
4	Heater-	Connect to Ground or 0V

Absolute Maximum Ratings

Stresses beyond those listed under [Absolute Maximum Ratings](#) may cause permanent damage to the device. These are stress ratings only. Functional operation of the device at these or any other conditions beyond those indicated under [Electrical Characteristics](#) is not implied. Exposure to absolute maximum rating conditions for extended periods may affect device reliability.

Figure 5:
Absolute Maximum Ratings

Symbol	Parameter	Min	Max	Units	Comments
Electrical Parameters					
V_H	Maximum Heater Voltage (V_H) ⁽¹⁾		1.8	V	
Electrostatic Discharge					
ESD_{HBM}	Human Body Model	± 1000		V	
Environmental Conditions					
T_{AMB}	Ambient Temperature for Operation	-5	50	°C	
T_{Strg}	Storage Temperature	-40	125	°C	
RH_{NC}	Relative Humidity (non-condensing)	10	95	%	
MSL	Moisture Sensitivity Level	1			Represents an unlimited floor life time

Note(s):

1. When V_H is produced by PWM of a V_{DD} above 1.8V the duty cycle (%) must not exceed $1.8V^2 / V_{DD}^2$.

Electrical Characteristics

Figure 6:
Electrical Characteristics

Parameters	Conditions	Min	Typ	Max	Units
Recommended Heater Voltage (V_H)		1.4	1.6		V
Average Power Consumption (P_{AV}) ⁽¹⁾			10.2		mW
Heater Resistance (R_H)	$V_H = 1.6V$	50	58	66	Ω
Sensor Resistance in Clean Air (R_a)	$V_H = 1.6V @ 50\% RH$	0.1	1.0	10	k Ω
Lifetime	$V_H = 1.4V$	>5			years

Note(s):

1. Based on 30s heater on time which includes a 20s warm-up period and a 10s measurement window performed once in a 2min period for Alcohol breath analysis. Refer to application note ([ams AN000366](#)) for more details.

Detailed Description

Sensor Performance

Figure 7:
Sensor Performance

Gas Type	Test Condition	Typical Sensitivity Range ^{(1),(2)}
Ethanol (C ₂ H ₅ OH)	R _a / R _{100ppm}	5-10

Note(s):

1. Defined as the sensor's resistance in air (R_a) divided by the sensor's resistance at a specific gas concentration level at 50% relative humidity and 25°C ambient temperature.
2. CCS803 performance in terms of resistance levels and sensitivities will change during early life use. The change in resistance is greatest over the first 48 hours of operation. **ams** advises customers to run CCS803 at V_H for 48 hours of operation to ensure sensor performance is stable.

Application Information

The recommended application circuit for CCS803 is shown below.

Figure 8:
Recommended Application Circuit

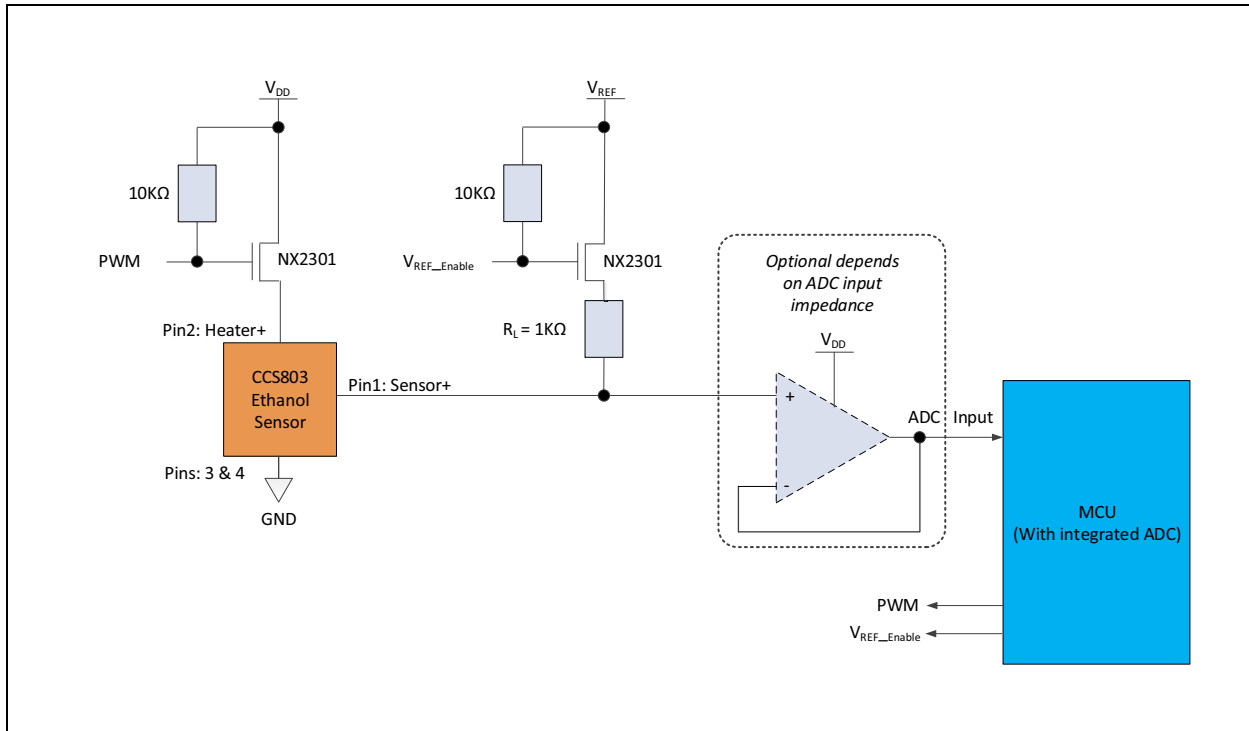

Note(s):

1. The sensor can be operated in pulsed mode to reduce overall power consumption. In this case the Heater V_H is only driven for a fraction of the time at regular intervals under the control of the MCU.
2. An equivalent V_H can be produced more efficiently with a PWM than with a linear regulator if a PWM output from the MCU is available to drive an external MOSFET switch (p-channel). If not driven the MOSFET input should be pulled high.
3. The PWM must operate with a minimum frequency of 10 kHz. The following table illustrates PWM duty cycle requirements to enable V_H in the range 1.4 – 1.6V for CCS803, other duty cycles can be calculated using the equation V_H^2 / V_{DD}^2 :

Target Heater Voltage (V_H)	Supply Voltage (V)				
	1.5V	1.8V	2.5V	3V	3.3V
1.40	87%	60%	31%	22%	18%
1.50	100%	69%	36%	25%	21%
1.60	-	79%	50%	28%	24%

4. An ADC input is required on the MCU to measure the sensor resistance, the recommended ADC reference voltage (V_{REF}) depends on what voltage range the ADC supports. Control of the sensor bias (V_{REF}) [e.g. by using an external MOSFET switch (p-channel)] is required to power the sensor bias only when needed for the ADC measurements, ensuring that all reference voltages are stable for the measurement.
5. A minimum load resistor (R_L) value of 1kΩ is recommended.

Package Information

DFN Package Outline

Figure 9:
DFN Package Drawings

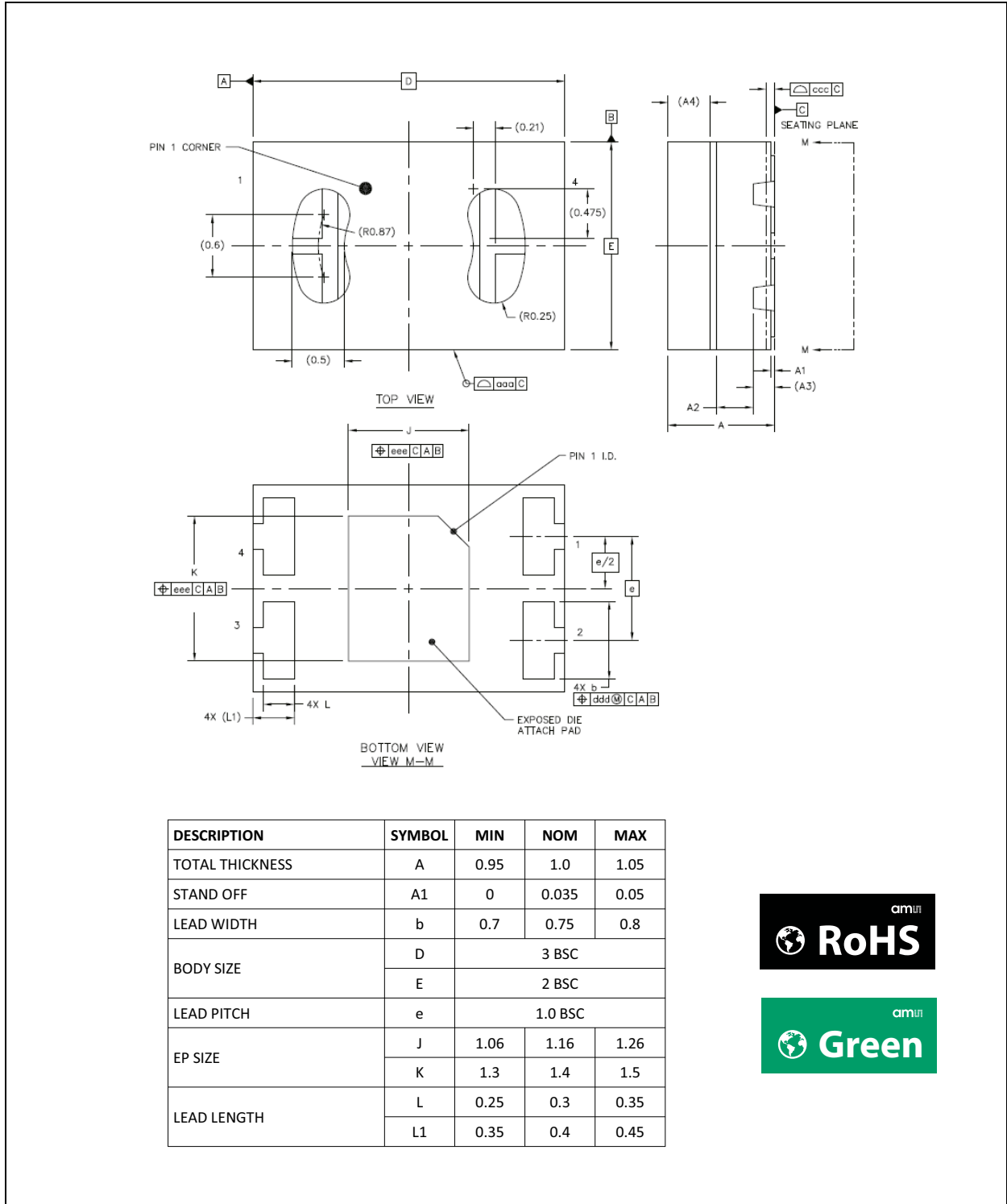

Note(s):

1. All dimensions are in millimeters.



The recommended package footprint or landing pattern for CCS803 is shown below:

Figure 10:
Recommended Package Footprint for CCS803

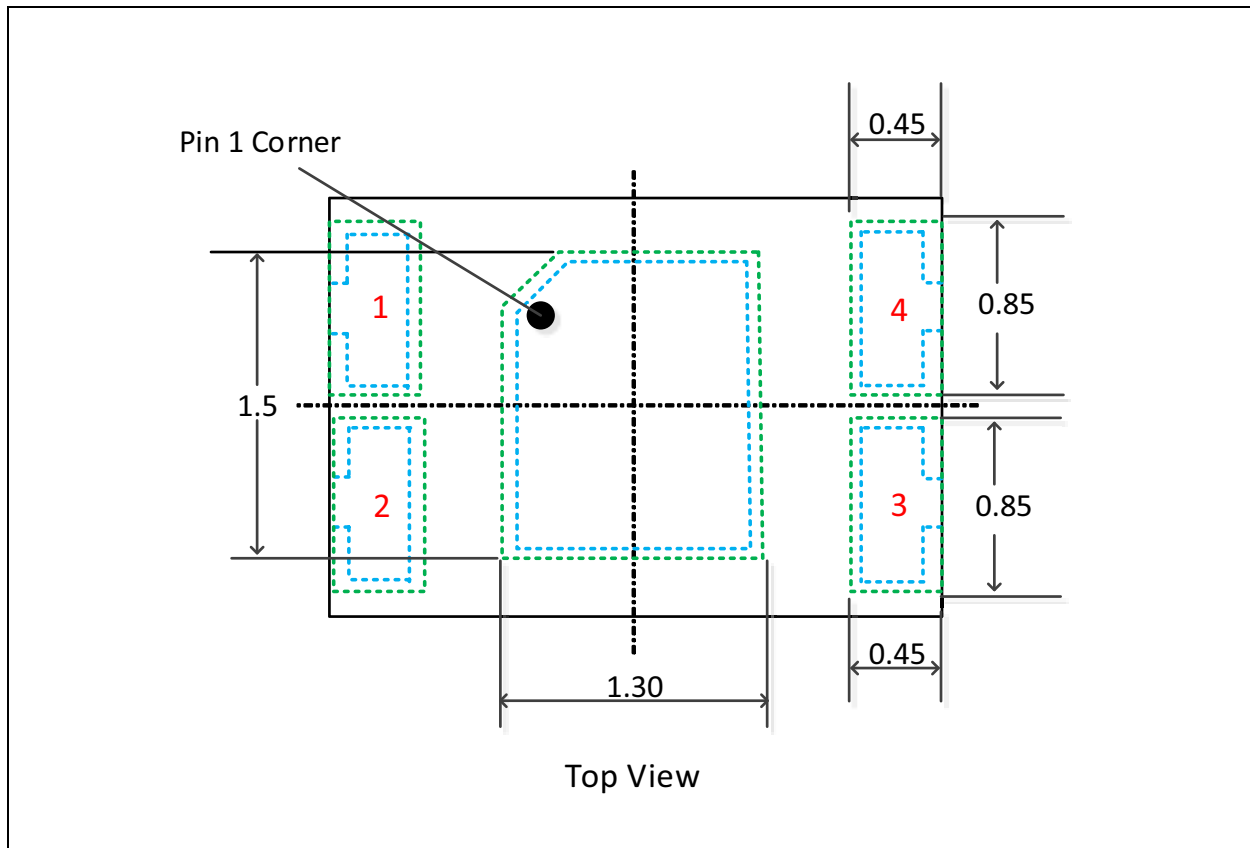

Note(s):

1. All dimensions are in millimeters.
2. PCB land pattern in Green dash lines
3. Pin numbers are in Red
4. Add 0.05mm all around the nominal lead width and length for the PCB land pattern

Ordering & Contact Information

Figure 11:
Ordering Information

Ordering Code	Description	Package	MOQ
CCS803A-COPR	CCS803 Ultra-low power gas sensor for ethanol detection	2mm x 3mm x 1mm DFN	5000
CCS803A-COPS	Sample of CCS803 Ultra-low power gas sensor for ethanol detection	2mm x 3mm x 1mm DFN	100

Note(s):

1. Refer to JEDEC J-STD020 lead-free standard for typical soldering reflow profile
2. Refer to application note CC-000090-AN (**ams** AN000364) on device assembly guidelines
3. Refer to application note CC-000018-AN (**ams** AN000363) on CCS80x hardware design guidelines.

Technical Support is available at:

www.ams.com/Technical-Support

Provide feedback about this document at:

www.ams.com/Document-Feedback

For further information and requests, e-mail us at:

ams_sales@ams.com

For sales offices, distributors and representatives, please visit:

www.ams.com/contact

Headquarters

ams AG
Tobelbader Strasse 30
8141 Premstaetten
Austria, Europe

Tel: +43 (0) 3136 500 0

Website: www.ams.com

RoHS Compliant & ams Green Statement

RoHS: The term RoHS compliant means that ams AG products fully comply with current RoHS directives. Our semiconductor products do not contain any chemicals for all 6 substance categories, including the requirement that lead not exceed 0.1% by weight in homogeneous materials. Where designed to be soldered at high temperatures, RoHS compliant products are suitable for use in specified lead-free processes.

ams Green (RoHS compliant and no Sb/Br): ams Green defines that in addition to RoHS compliance, our products are free of Bromine (Br) and Antimony (Sb) based flame retardants (Br or Sb do not exceed 0.1% by weight in homogeneous material).

Important Information: The information provided in this statement represents ams AG knowledge and belief as of the date that it is provided. ams AG bases its knowledge and belief on information provided by third parties, and makes no representation or warranty as to the accuracy of such information. Efforts are underway to better integrate information from third parties. ams AG has taken and continues to take reasonable steps to provide representative and accurate information but may not have conducted destructive testing or chemical analysis on incoming materials and chemicals. ams AG and ams AG suppliers consider certain information to be proprietary, and thus CAS numbers and other limited information may not be available for release.

Copyrights & Disclaimer

Copyright ams AG, Tobelbader Strasse 30, 8141 Premstaetten, Austria-Europe. Trademarks Registered. All rights reserved. The material herein may not be reproduced, adapted, merged, translated, stored, or used without the prior written consent of the copyright owner.

Devices sold by ams AG are covered by the warranty and patent indemnification provisions appearing in its General Terms of Trade. ams AG makes no warranty, express, statutory, implied, or by description regarding the information set forth herein. ams AG reserves the right to change specifications and prices at any time and without notice. Therefore, prior to designing this product into a system, it is necessary to check with ams AG for current information. This product is intended for use in commercial applications. Applications requiring extended temperature range, unusual environmental requirements, or high reliability applications, such as military, medical life-support or life-sustaining equipment are specifically not recommended without additional processing by ams AG for each application. This product is provided by ams AG "AS IS" and any express or implied warranties, including, but not limited to the implied warranties of merchantability and fitness for a particular purpose are disclaimed.

ams AG shall not be liable to recipient or any third party for any damages, including but not limited to personal injury, property damage, loss of profits, loss of use, interruption of business or indirect, special, incidental or consequential damages, of any kind, in connection with or arising out of the furnishing, performance or use of the technical data herein. No obligation or liability to recipient or any third party shall arise or flow out of ams AG rendering of technical or other services.

Document Status

Document Status	Product Status	Definition
Product Preview	Pre-Development	Information in this datasheet is based on product ideas in the planning phase of development. All specifications are design goals without any warranty and are subject to change without notice
Preliminary Datasheet	Pre-Production	Information in this datasheet is based on products in the design, validation or qualification phase of development. The performance and parameters shown in this document are preliminary without any warranty and are subject to change without notice
Datasheet	Production	Information in this datasheet is based on products in ramp-up to full production or full production which conform to specifications in accordance with the terms of ams AG standard warranty as given in the General Terms of Trade
Datasheet (discontinued)	Discontinued	Information in this datasheet is based on products which conform to specifications in accordance with the terms of ams AG standard warranty as given in the General Terms of Trade, but these products have been superseded and should not be used for new designs

Revision Information

Changes from CCMOSS version 11 (2016-May-26) to current revision 1-00 (2016-Dec-23)	Page
Content of CCMOS Sensors datasheet was updated to the latest ams design	

Note(s):

1. Page and figure numbers for the previous version may differ from page and figure numbers in the current revision.
2. Correction of typographical errors is not explicitly mentioned.

Content Guide

1	General Description
1	Product Overview
2	Key Benefits & Features
2	Applications
3	Pin Assignment
4	Absolute Maximum Ratings
5	Electrical Characteristics
6	Detailed Description
6	Sensor Performance
7	Application Information
8	Package Information
8	DFN Package Outline
10	Ordering & Contact Information
11	RoHS Compliant & ams Green Statement
12	Copyrights & Disclaimer
13	Document Status
14	Revision Information