

信昌電子陶瓷股份有限公司  
Prosperity Dielectrics Co., Ltd.

No.566-1, Gaoshi Rd., Lujhu, Yangmei Dist., Taoyuan City 32668, Taiwan, R.O.C.  
Tel. : +886-3-4753355 Fax : +886-3-4854959

**SPECIFICATION FOR APPROVAL**

DATE :

CUSTOMER : \_\_\_\_\_

PART NAME : \_\_\_\_\_ Metal Paste Low Ohm Current Sense Chip-Resistor

CUSTOMER'S DWG. NO. : \_\_\_\_\_

CUSTOMER'S PART NO. : \_\_\_\_\_

PDC PART NO. : \_\_\_\_\_ FBF SERIES APPROVED

DESCRIPTION. : \_\_\_\_\_

ACTION	"V"	CUSTOMER'S SIGNATURE	NOTE
RESULT			
FULL APPROVED			
CONDITIONAL APPROVED			
REJECTED			

OUR ACTION	SIGNATURE
PREPARED By	<i>Jenny Tseng</i>
CHECKED By	<i>Tony Chou</i>
APPROVED By	<i>Byron Tsai</i>

CUSTOMER SIGNATURE FOR ACCEPTANCE

---

1. Features .....	2
2. Applications.....	2
3. Dimension and construction .....	2
4. Power Derating Curve .....	3
5. Rating .....	4
6. Part Number .....	5
7. Resistance Marking / Soldering .....	5
8. Reliability Performance.....	7
9. Packing .....	8
9.1 Peel Strength of Top Cover Tape.....	8
9.2 Tape Packaging Dimensions.....	8
9.3 Reel Dimensions.....	9
10. Storage / Handling .....	9

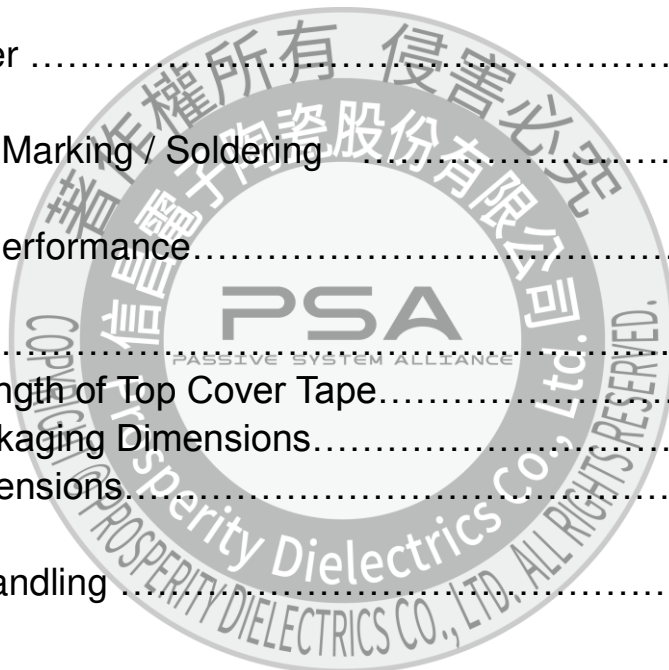

### 1. Features

- Low resistance and high precision (1%).
- Excellent reliability and suitable cost.
- Suitable for lead free soldering.
- RoHS compliant & Halogen Free.

### 2. Applications

- Consumer electronics, M/B.
- Battery pack, BTC.
- Notebook, Tablet PC.
- Portable Device, Electronic Equipment.

### 3. Dimensions and Constructions



Unit : mm

Type 1.	L	W	C	D	T
FBF03	1.60±0.10	0.80±0.10	0.30±0.20	0.30±0.20	0.45±0.10
FBF05	2.00±0.10	1.25±0.10	0.40±0.20	0.40±0.20	0.50±0.10
FBF06	3.10±0.10	1.60±0.10	0.50±0.25	0.50±0.25	0.55±0.10
FBF12	3.10±0.10	2.60±0.10	0.50±0.25	0.50±0.25	0.55±0.10
FBF20	5.00±0.20	2.50±0.20	0.60±0.25	0.60±0.25	0.60±0.10
FBF25	6.30±0.20	3.10±0.20	0.60±0.25	0.90±0.25	0.60±0.15

Type 2.	L	W	C	D	T
FBF03	1.60±0.10	0.80±0.10	0.30±0.20	0.50±0.20	0.50±0.10
FBF05	2.00±0.10	1.25±0.10	0.40±0.20	0.65±0.20	0.60±0.10
FBF06	3.10±0.10	1.60±0.10	0.50±0.25	0.90±0.25	0.65±0.10
FBF12	3.10±0.10	2.60±0.10	0.50±0.25	0.90±0.25	0.65±0.10
FBF20	5.00±0.20	2.50±0.20	0.60±0.25	1.25±0.25	0.65±0.10
FBF25	6.30±0.20	3.10±0.20	0.60±0.25	1.90±0.25	0.65±0.15

Type 1. Resistance  $\geq 40\text{m}\Omega$



Type 2. Resistance  $\leq 39\text{m}\Omega$

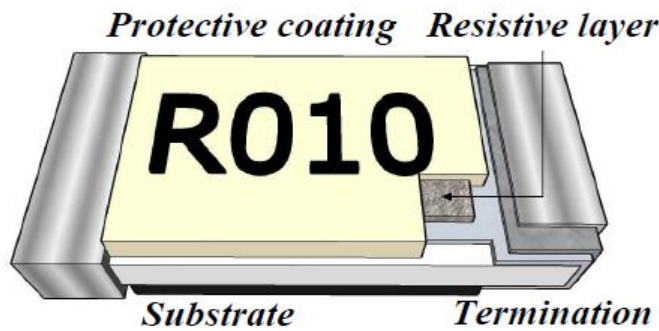

#### 4. Power Derating Curve

Operating Temperature Range:  $-55$  to  $+155^\circ\text{C}$

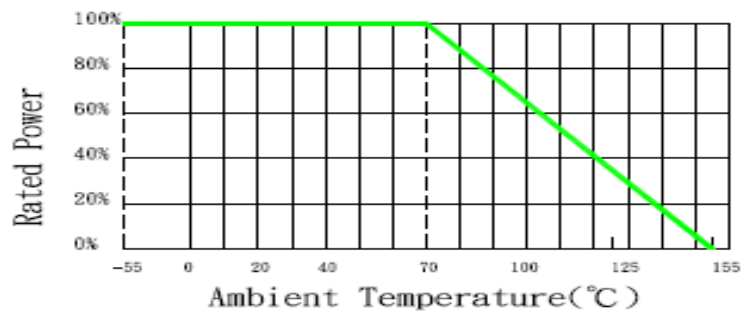

**FBF series. (Metal Paste)**  
**Current Sensing Resistors**  
**Thick-film Chip Resistors**

**5. Rating**

Normal Type		Power Rating at 70°C	Max. RCWV (mV)	Max. Overload Voltage (mV)	Resistance Tolerance (%)	Temperature Coefficient (TCR; ppm/°C)	Resistance Range (mΩ)		Standard Resistance Values
Type	Size						Min.	Max.	
FBF03	0603	1/8W	337	754	±1、±2、±5	±200	40	91	E-24
							±100	100	
FBF05	0805	1/4W	477	1067	±1、±2、±5	±400~±200	10	46	E-24
							±100	47	
FBF06	1206	1/3W	551	1232	±1、±2、±5	±400~±200	10	46	E-24
							±100	47	
FBF12	1210	2/3W	779	1742	±1、±2、±5	±400~±200	10	46	E-24
							±100	47	
FBF20	2010	3/4W	826	1847	±1、±2、±5	±400~±200	10	46	E-24
							±100	47	
FBF25	2512	1W	954	2133	±1、±2、±5	±400~±200	10	46	E-24
							±100	47	
Power Type		Power Rating at 70°C	Max. RCWV (mV)	Max. Overload Voltage (mV)	Resistance Tolerance (%)	Temperature Coefficient (TCR; ppm/°C)	Resistance Range (mΩ)		Standard Resistance Values
Type	Size						Min.	Max.	
FBF03	0603	1/4W	477	1067	±1、±2、±5	±200	40	91	E-24
							±100	100	
FBF05	0805	1/2W	675	1508	±1、±2、±5	±400~±200	10	46	E-24
							±100	47	
FBF06	1206	3/4W	826	1847	±1、±2、±5	±400~±200	10	46	E-24
							±100	47	
FBF12	1210	3/4W	826	1847	±1、±2、±5	±400~±200	10	46	E-24
							±100	47	
FBF20	2010	1W	954	2133	±1、±2、±5	±400~±200	10	46	E-24
							±100	47	
FBF25	2512	2W	1349	3017	±1、±2、±5	±400~±200	10	46	E-24
							±100	47	

Note :

1. RCWV =  $(P \times R)^{1/2}$  or Max. RCWV listed above, whichever is lower.

RCWV : Rated Continue Working Voltage(V) · P : Rated Power(W) · R : Resistance Value( $\Omega$ )

2. Special resistance value request please contact factory.

3. 10m $\Omega$ ~18m $\Omega$ :TCR  $\pm$ 400ppm

## 6. Part Number

Type	Size	Tolerance	Packing	Power Code	R Value (GM)	Control Code
<b>FBF</b>	<b>03</b> :0603	<b>F</b> : $\pm$ 1%	<b>Paper Tape :</b> <b>0603.0805.1206</b> <b>1210</b> <b>I</b> : 5Kpcs <b>V</b> : 10Kpcs <b>W</b> : 20Kpcs <b>Plastic Tape :</b> <b>2010.2512</b> <b>P</b> : 4Kpcs <b>X</b> : 8Kpcs <b>Y</b> : 16Kpcs	<b>Normal</b> Rating <b>P:</b> <b>Power</b> Rating	<b>XXXX</b> 4 digits	<b>K</b> <b>R010~R018</b> <b>Control code</b>
	<b>05</b> :0805	<b>G</b> : $\pm$ 2%				
	<b>06</b> :1206	<b>J</b> : $\pm$ 5%				
	<b>12</b> :1210					
	<b>20</b> :2010					
	<b>25</b> :2512					

Example :

### FBF06FT-R100

→ 1206 size, tolerance 1%, paper tape, 100m $\Omega$

### FBF25FP-R015K

→ 2512 size, tolerance 1%, plastic tape, 15m $\Omega$ .

## 7. Marking/Soldering

**Resistance value identify :**

0805/1206/1210/2010/2512

Top Marking. ( 4 Digits marking to identify the resistance value. )

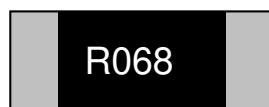

R068=68m $\Omega$  , R120=120m $\Omega$

0603

Top Marking. ( 3 Digits marking to identify the resistance value. )



R12=120mΩ , 68M=68mΩ

**Soldering Reference :**

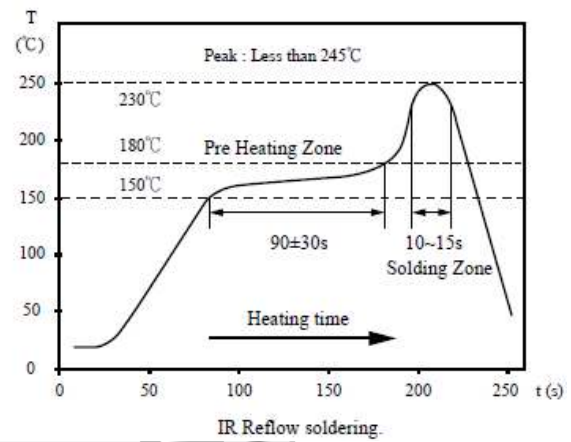
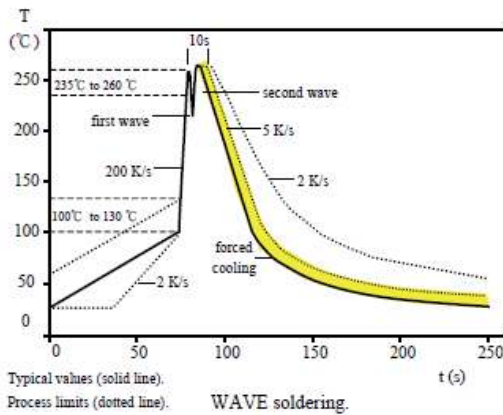

**Recommend Solder Pad Dimensions :**

Type	W	D	L
<b>FBF03</b>	0.90	1.00	3.00
<b>FBF05</b>	1.30	1.15	3.50
<b>FBF06</b>	1.80	1.30	4.70
<b>FBF12</b>	3.00	1.30	4.70
<b>FBF20</b>	3.00	1.50	6.80
<b>FBF25</b>	3.70	1.60	7.60

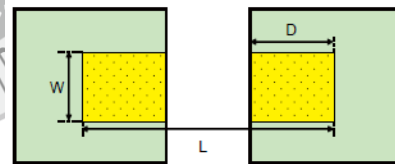

Unit:mm

## 8. Reliability Performance

Test Item	Specification	Test Method
<b>DC Resistance</b>	F : ±1%    G : ±2% J : ±5%	<b>IEC 60115-1 / JIS C 5201-1 , Clause 4.5</b> Measure the resistance Value.
<b>Resistance to Solder Heat</b>	$\Delta R \leq \pm(1\% + 0.5m\Omega)$ F : $\Delta R \leq \pm(0.5\% + 0.5m\Omega)$ No mechanical damage	<b>IEC 60115-1, Clause 4.18</b> Solder dipping @ 260°C±5°C for 10sec.±1sec.
<b>Solder Ability</b>	Over 95% of termination must be covered with Solder.	<b>IEC 60115-1, Clause 4.17</b> After immersing flux, dip in the 245±2°C molten solder bath for 3±0.5 sec.
<b>Short Time Overload</b>	$\Delta R \leq \pm(2\% + 0.5m\Omega)$ F : $\Delta R \leq \pm(1\% + 0.5m\Omega)$	<b>IEC 60115-1, Clause 4.13</b> 5 × Rated power for 5 seconds
<b>Temperature Coefficient of Resistance (TCR)</b>	Within the spec.	<b>IEC 60115-1, Clause 4.8</b> $T_1$ $T_2$ Test temperature : 25°C ~ 155°C $TCR(ppm/^\circ C) = (R_2 - R_1) / R_1 \times 1 / (T_2 - T_1) \times 10^6$
<b>Load Life</b>	$\Delta R \leq \pm(3\% + 0.5m\Omega)$	<b>IEC 60115-1, Clause 4.25</b> Rated voltage for 1.5 hours for followed by a pause 0.5 hour at 70±2°C. Cycle repeated 1000 hours.
<b>Bending strength</b>	$\Delta R \leq \pm(1\% + 0.5m\Omega)$ F : $\Delta R \leq \pm(0.5\% + 0.5m\Omega)$ No mechanical damage.	<b>IEC 60115-1 / JIS C 5201-1 , Clause 4.33</b> Resistance variance after bended on the 90mm PCB. Bending width : 3mm for 0603 0805 2mm for 1206 2010 2512
<b>Insulation Resistance</b>	Between termination and coating must over 1000MΩ	<b>IEC 60115-1, Clause 4.6</b> Test voltage : 100±15V



## 9. PACKAGING

### 9.1 Peel Strength of Top Cover Tape

The peel speed shall be about 300 mm/min

The peel force of top cover tape shall be between 0.1 to 0.7N

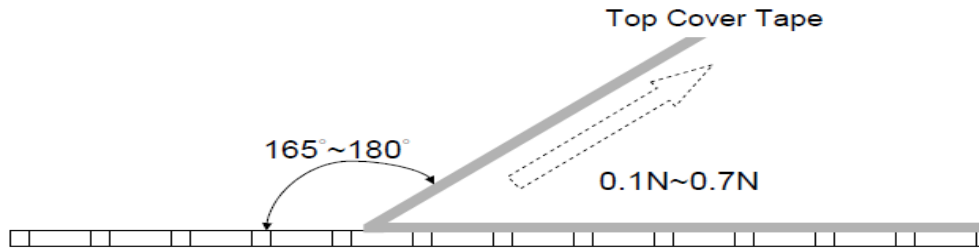

### 9.2 Tape Packaging Dimensions

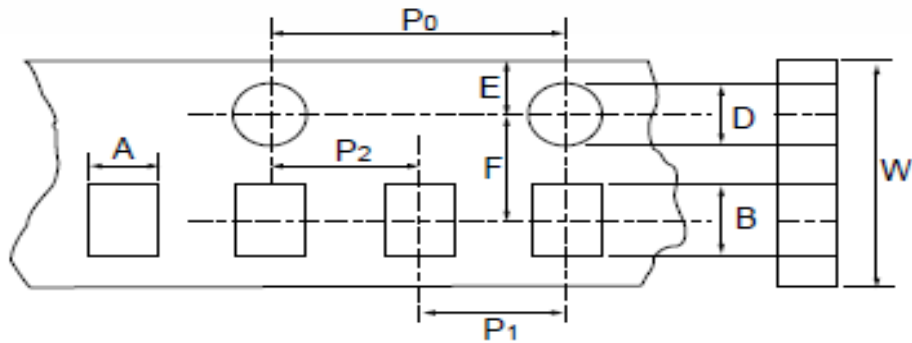

• Accumulated dimensional tolerance  $40 \pm 0.2 \text{mm}$

unit:mm

Size	A	B	W	F	E	P1	P2	P0	D
0603	1.10±0.20	1.90±0.20	8.00±0.30	3.50±0.05	1.75±0.10	4.00±0.10	2.00±0.05	4.00±0.10	1.50+0.10/-0
0805	1.65±0.20	2.40±0.20	8.00±0.30	3.50±0.05	1.75±0.10	4.00±0.10	2.00±0.05	4.00±0.10	1.50+0.10/-0
1206	2.00±0.20	3.60±0.20	8.00±0.30	3.50±0.05	1.75±0.10	4.00±0.10	2.00±0.05	4.00±0.10	1.50+0.10/-0
1210	3.00±0.20	3.60±0.20	8.00±0.30	3.50±0.05	1.75±0.10	4.00±0.10	2.00±0.05	4.00±0.10	1.50+0.10/-0
2010	2.80±0.20	5.50±0.20	12.00±0.30	5.50±0.05	1.75±0.10	4.00±0.10	2.00±0.05	4.00±0.10	1.50+0.10/-0
2512	3.50±0.20	6.70±0.20	12.00±0.30	5.50±0.05	1.75±0.10	4.00±0.10	2.00±0.05	4.00±0.10	1.50+0.10/-0

### 9.3 Reel Dimensions

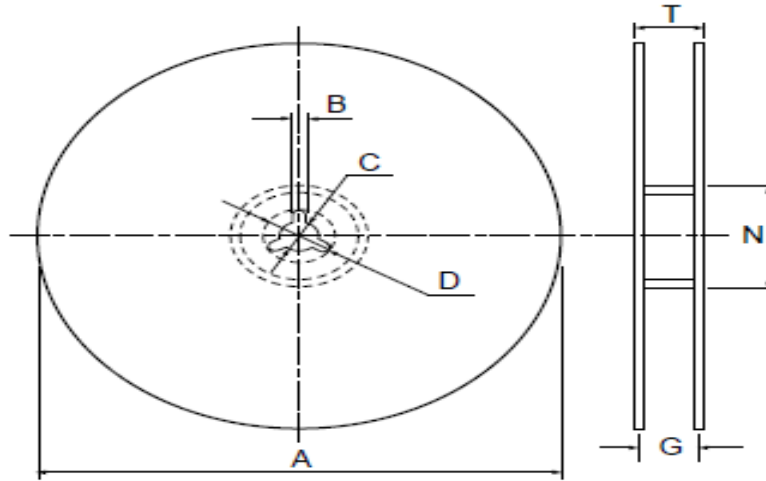

Size	Packaging Q'ty	A	N	C	D	B	G	T
0603	5kpcs/Reel	178.0±2.0	60.0±0.5	13.0±0.5	20(Min.)	2.0±0.5	10.0±1.5	14.9max.
0805	10kpcs/Reel	254.0±2.0	100.0±1.0	13.5±0.5	20(Min.)	2.0±0.5	10.0±1.5	14.9max.
1206	20kpcs/Reel	330.0±2.0	100.0±1.0	13.5±0.5	20(Min.)	2.0±0.5	10.0±1.5	14.9max.
2010 2512	4kpcs/Reel	178.0±2.0	60.0±0.5	13.0±0.5	20(Min.)	2.0±0.5	13.8±1.5	16.7max.
	8kpcs/Reel	254.0±2.0	100.0±0.5	13.5±0.5	20(Min.)	2.0±0.5	13.8±1.5	20.0max.
	16kpcs/Reel	330.0±2.0	100.0±1.0	13.5±0.5	20(Min.)	2.0±0.5	13.8±1.5	20.0max.

unit:mm

### 10. Storage & Handling

... Products are recommended to be used up within one year as ensured shelf life.

Check solder ability in case shelf life extension is needed.

... To store products with following condition:

Temperature:5 to 40℃ ; Humidity: 20 to 70% relative humidity.

※ All product specification and data are subject to change without notice.