

DO NOT SCALE FROM THIS PRINT

END OPTION	"C"	"D"
XL, XR	0.650 [16.51]	0.218 [5.54]
XD	0.788 [20.02]	0.264 [6.71]
XH	0.788 [20.02]	0.264 [6.71]

No. OF POSITIONS	N	N-1
-005	10	9
-010	20	19
-020	40	39
-030	60	59
-040	80	79
-050	100	99

END TO END	"A"
DV TO DV	0.860 [21.84]
DV TO DH	0.998 [25.35]
DV TO RH	0.998 [25.35]
DH TO DH	1.136 [28.85]
DH TO RH	1.136 [28.85]
RH TO RH	1.136 [28.85]

HLCD-XX-XX.XX-XXX-XXX-X-X

No. OF POSITIONS
-05, -10, -20, -30, -40, -50
(PER ROW)

LENGTH
-XX.XX (INCHES)
(01.72 [43.7] MIN)

CABLE OPTION
(BLANK): TCF-3850-XX-01
-T:(SEE NOTE 12)

WIRING OPTION
-1: 1-1
-2: 1-2
-3: 1-(N-1)
-4: 1-N

SECOND END OPTION
-S: SCREW DOWN OPTION IN PCB
(LEAVE BLANK FOR NON-SCREW DOWN)
(SCREW DOWN ONLY AVAILABLE FOR -TR, -TL, -BR, -BL OPTIONS, SEE FIG. 2)

FIG 1
VERTICAL TO DH
HLCD-20-XX.XX-TR-TD-1 SHOWN

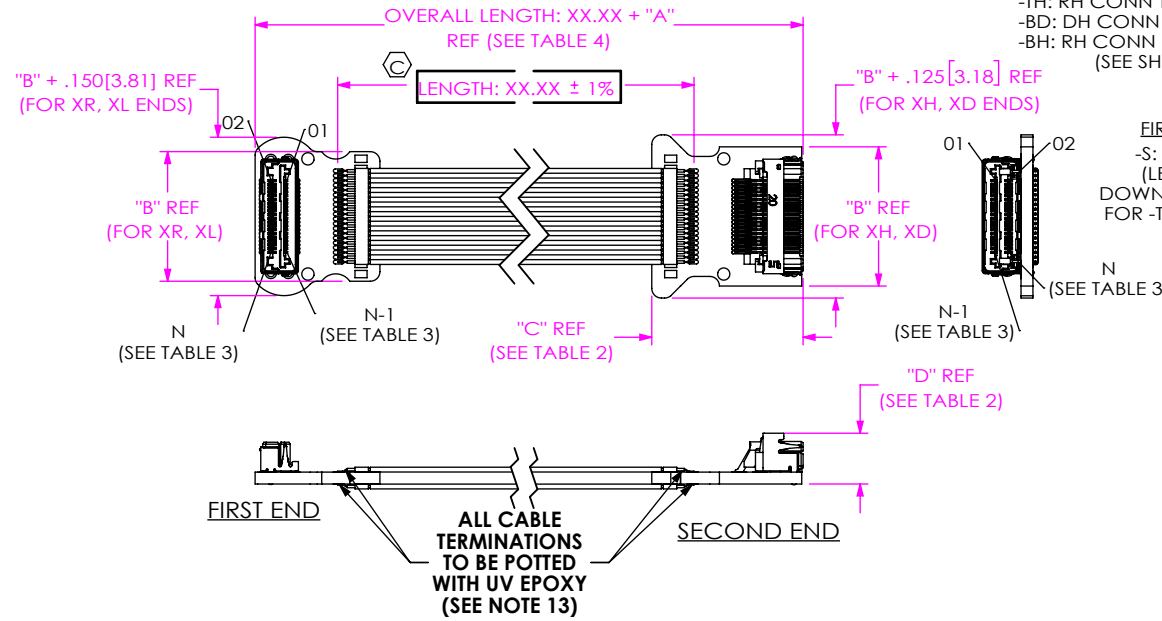

FIRST END OPTION
-S: SCREW DOWN OPTION IN PCB
(LEAVE BLANK FOR NON-SCREW DOWN)
(SCREW DOWN ONLY AVAILABLE FOR -TR, -TL, -BR, -BL OPTIONS, SEE FIG. 2)

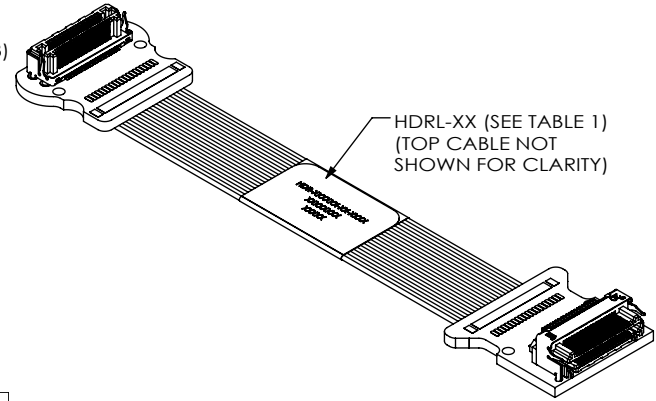

No. OF POSITIONS	"B" (XR, XL)	"B" (XH, XD)	BLANK OPTION (CABLE)	-T OPTION (CABLE)	QTY OF SUB-TCF	SUB-HLCD-XX-XX-XX-X-L2.5	BLANK OPTION (LABEL)	-T OPTION (LABEL)
-005	380 [9.65]	430 [10.92]	SUB-TCF-3850-05-01-XX-XX	SUB-TCF-3850F-05-T01-XX-XX	2	SUB-HLCD-05-XX-XX-X-L2.5	HDRL-11	HDRL-47
-010	478 [12.14]	528 [13.41]	SUB-TCF-3850-10-01-XX-XX	SUB-TCF-3850F-10-T01-XX-XX	2	SUB-HLCD-10-XX-XX-X-L2.5	HDRL-11	HDRL-47
-020	675 [17.15]	725 [18.42]	SUB-TCF-3850-20-01-XX-XX	SUB-TCF-3850F-20-T01-XX-XX	2	SUB-HLCD-20-XX-XX-X-L2.5	HDRL-11	HDRL-47
-030	975 [24.77]	1,025 [26.04]	SUB-TCF-3850-30-01-XX-XX	SUB-TCF-3850F-30-T01-XX-XX	2	SUB-HLCD-30-XX-XX-X-L2.5	HDRL-11	HDRL-47
-040	1,275 [32.39]	1,325 [33.66]	SUB-TCF-3850-40-01-XX-XX	SUB-TCF-3850F-40-T01-XX-XX	4	SUB-HLCD-40-XX-XX-X-L2.5	HDRL-11	HDRL-47
-050	1,575 [40.01]	1,625 [41.28]	SUB-TCF-3850-50-01-XX-XX	SUB-TCF-3850F-50-T01-XX-XX	4	SUB-HLCD-50-XX-XX-X-L2.5	HDRL-11	HDRL-47

CRITICAL DIMENSION INSPECTION INSTRUCTION TABLE	
ASSEMBLY OPERATION	IN-PROCESS INSPECTION
PREP CABLE	C1
E-TEST	C2, C3

- NOTES:
- ⊙ REPRESENTS A CRITICAL DIMENSION.
 - PARTS TO BE PROCESSED PER SAMTEC BOUNDARY DOCUMENT GUIDELINES.
 - ALL ASSEMBLIES TO BE 100% ELECTRICALLY TESTED.
 - ALL ASSEMBLIES TO BE 100% HI-POT TESTED AT 300V.
 - HDRL-11 TO BE CENTERED ON CABLE AS SHOWN. LABEL TO CONTAIN:
LINE 1 - PART NUMBER "HLCD-XX-XX.XX-XXX-XXX-X"
LINE 2 - SHOP ORDER NUMBER "XXXXXX"
LINE 3 - DATE CODE "XXXXX".
 - FOR SUB-ASSEMBLY AND FINISHED GOOD PACKAGING REQUIREMENTS, REFERENCE PACKAGING STANDARD CO-HD-WI-3033-M.
 - SUB-TCF LENGTH IS EQUAL TO HLCD LENGTH.
 - CABLE LENGTHS GREATER THAN 40.00 INCHES ARE NOT SUPPORTED BY SI TEST DATA.
 - ALL PINS ROUTED AS SIGNALS. LSHM SHIELD TIED TO COAX SHIELD FOR GROUND RETURN.
 - DO NOT PULL** ON COAX RIBBON TO UNMATE CABLE ASSEMBLY.
 - ON DV END OPTIONS PIN 01 LOCATION DENOTES LEFT OR RIGHT ORIENTATION.
 - T OPTION: HIGH TEMP THV JACKET & WHITE PVF LABEL
 - EPOXY: IF CABLE OPTION IS -T, USE EPOXY-06 ONLY ON ALL CABLE TERMINATIONS. IF BLANK, USE EPOXY-42 ON ALL CABLE TERMINATIONS.

Pb THIS PRODUCT MANUFACTURED WITH LEAD-FREE PROCESSING

UNLESS OTHERWISE SPECIFIED, DIMENSIONS ARE IN INCHES. TOLERANCES ARE:
DECIMALS ANGLES
.XX: ±.01 [0.3]
.XXX: ±.005 [0.13]
.XXXX: ±.0020 [0.051]

PROPRIETARY NOTE
THIS DOCUMENT CONTAINS CONFIDENTIAL AND PROPRIETARY INFORMATION AND ALL DESIGN, MANUFACTURING, REPRODUCTION, USE, PATENT RIGHTS AND SALES RIGHTS ARE EXPRESSLY RESERVED BY SAMTEC, INC. THIS DOCUMENT SHALL NOT BE DISCLOSED, IN WHOLE OR PART, TO ANY UNAUTHORIZED PERSON OR ENTITY NOR REPRODUCED, TRANSFERRED OR INCORPORATED IN ANY OTHER PROJECT IN ANY MANNER WITHOUT THE EXPRESS WRITTEN CONSENT OF SAMTEC, INC.

samtec
520 PARK EAST BLVD., NEW ALBANY, IN 47150
PHONE: 812-944-6733 FAX: 812-948-5047
e-Mail: info@SAMTEC.com code 55322

FIRST END (SEE TABLE 6, SHEET 4)
(FIRST END BOARDS WILL HAVE BLACK SOLDER MASK)

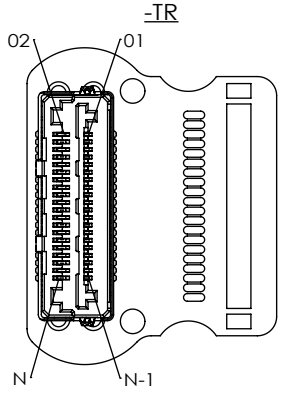

WIRING OPTION	FIRST END PIN #	SECOND END PIN #
1	1	1
2	1	2
3	1	N-1
4	1	N

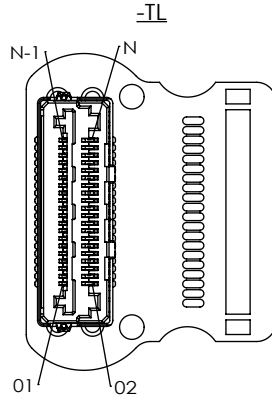

WIRING OPTION	FIRST END PIN #	SECOND END PIN #
1	1	1
2	1	2
3	1	N-1
4	1	N

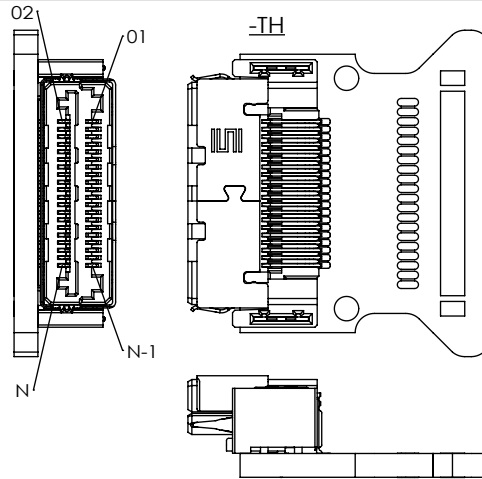

WIRING OPTION	FIRST END PIN #	SECOND END PIN #
1	1	1
2	1	2
3	1	N-1
4	1	N

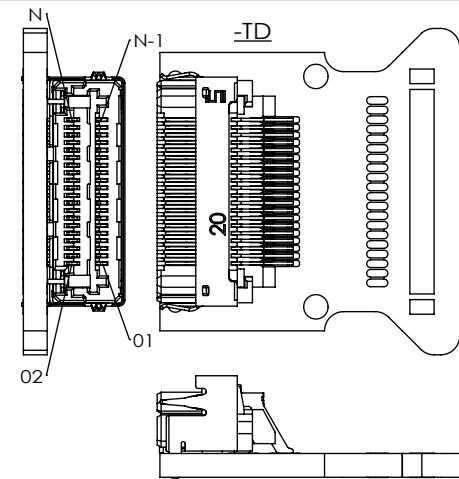

WIRING OPTION	FIRST END PIN #	SECOND END PIN #
1	1	1
2	1	2
3	1	N-1
4	1	N

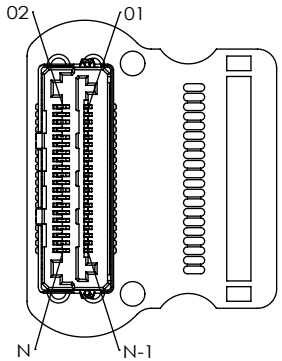
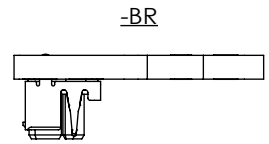

WIRING OPTION	FIRST END PIN #	SECOND END PIN #
1	1	1
2	1	2
3	1	N-1
4	1	N

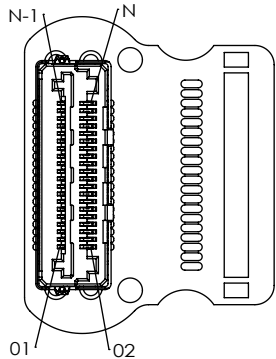
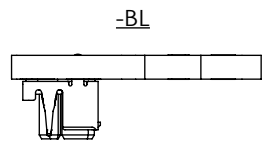

WIRING OPTION	FIRST END PIN #	SECOND END PIN #
1	1	1
2	1	2
3	1	N-1
4	1	N

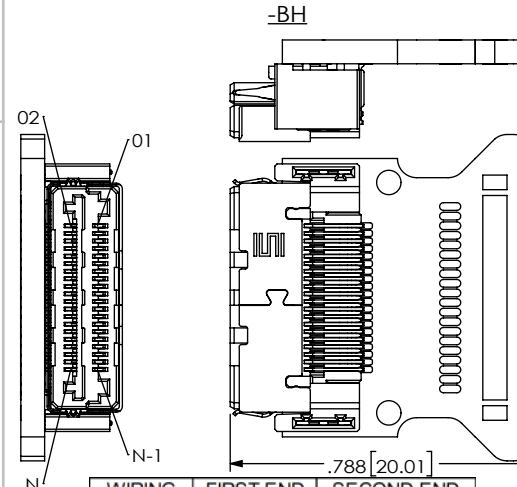

WIRING OPTION	FIRST END PIN #	SECOND END PIN #
1	1	1
2	1	2
3	1	N-1
4	1	N

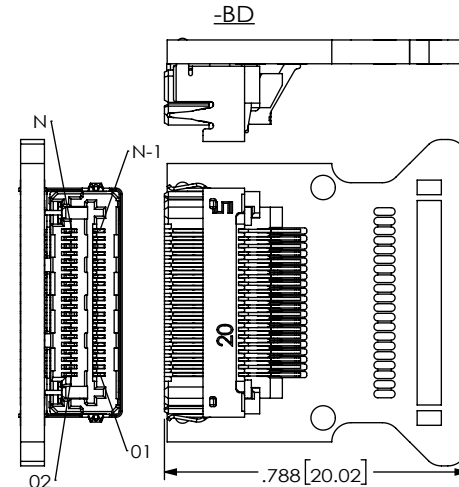

WIRING OPTION	FIRST END PIN #	SECOND END PIN #
1	1	1
2	1	2
3	1	N-1
4	1	N

PROPRIETARY NOTE
THIS DOCUMENT CONTAINS CONFIDENTIAL AND PROPRIETARY INFORMATION AND ALL DESIGN, MANUFACTURING, REPRODUCTION, USE, PATENT RIGHTS AND SALES RIGHTS ARE EXPRESSLY RESERVED BY SAMTEC, INC. THIS DOCUMENT SHALL NOT BE DISCLOSED, IN WHOLE OR PART, TO ANY UNAUTHORIZED PERSON OR ENTITY NOR REPRODUCED, TRANSFERRED OR INCORPORATED IN ANY OTHER PROJECT IN ANY MANNER WITHOUT THE EXPRESS WRITTEN CONSENT OF SAMTEC, INC.

DO NOT SCALE DRAWING

SHEET SCALE: 1:25:1



520 PARK EAST BLVD, NEW ALBANY, IN 47150
PHONE: 812-944-6733 FAX: 812-948-5047
e-Mail: info@SAMTEC.com code 55322

DESCRIPTION:
LSHM CABLE ASSEMBLY

DWG. NO.
HLCD-XX-XX.XX-XXX-XXX-X-X
BY: ANDREW C 05/29/2013 SHEET 2 OF 4

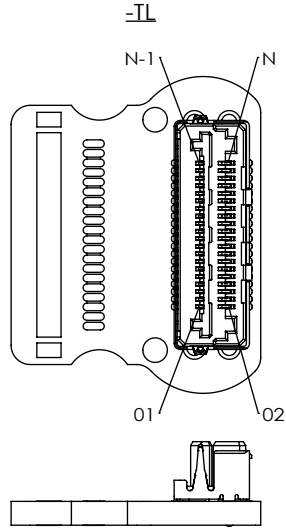

WIRING OPTION	FIRST END PIN #	SECOND END PIN #
1	1	1
2	1	2
3	1	N-1
4	1	N

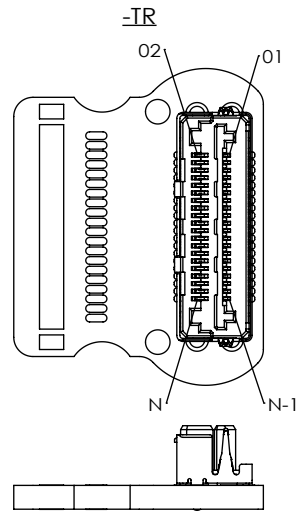

WIRING OPTION	FIRST END PIN #	SECOND END PIN #
1	1	1
2	1	2
3	1	N-1
4	1	N

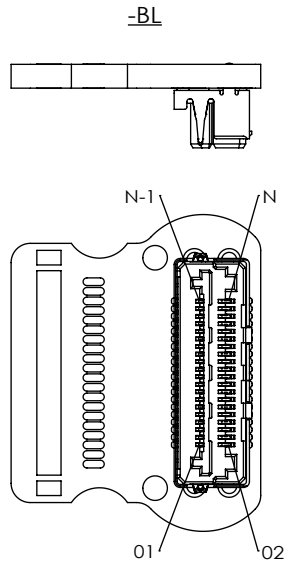

WIRING OPTION	FIRST END PIN #	SECOND END PIN #
1	1	1
2	1	2
3	1	N-1
4	1	N

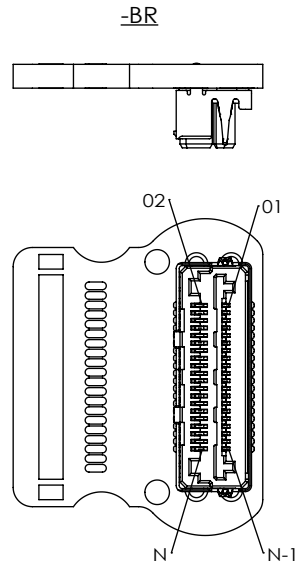

WIRING OPTION	FIRST END PIN #	SECOND END PIN #
1	1	1
2	1	2
3	1	N-1
4	1	N

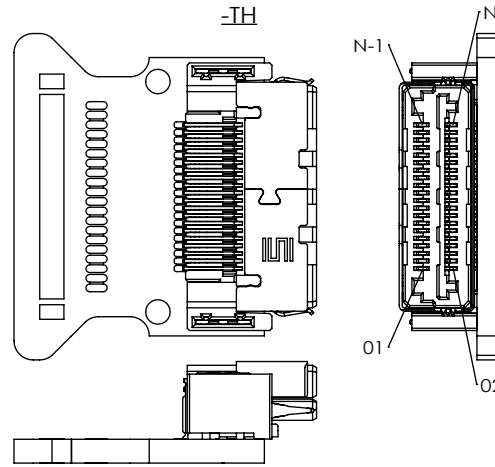

WIRING OPTION	FIRST END PIN #	SECOND END PIN #
1	1	1
2	1	2
3	1	N-1
4	1	N

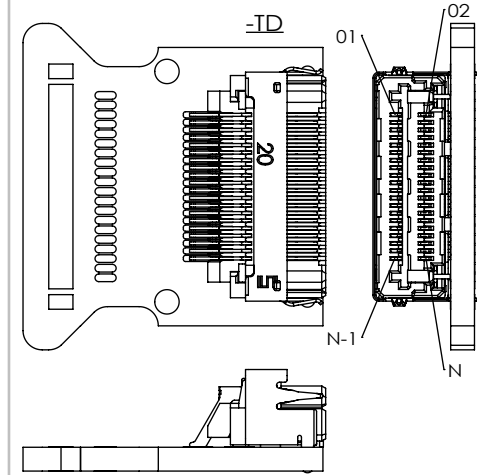

WIRING OPTION	FIRST END PIN #	SECOND END PIN #
1	1	1
2	1	2
3	1	N-1
4	1	N

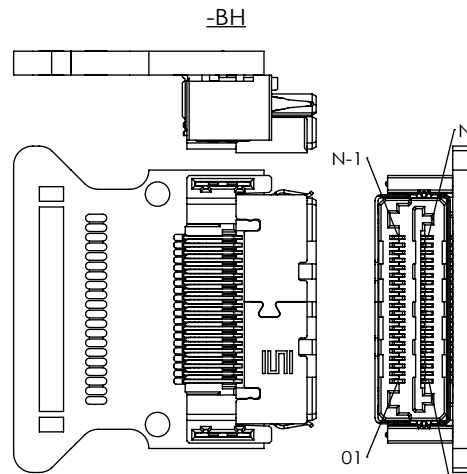

WIRING OPTION	FIRST END PIN #	SECOND END PIN #
1	1	1
2	1	2
3	1	N-1
4	1	N

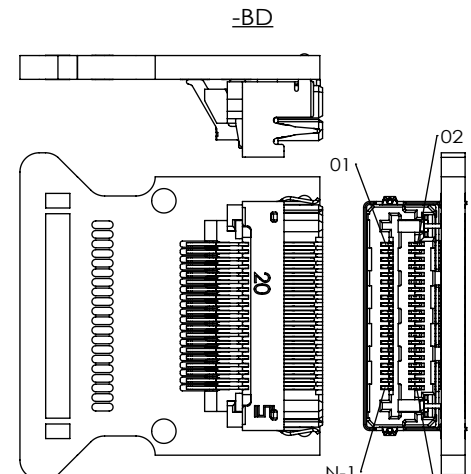

WIRING OPTION	FIRST END PIN #	SECOND END PIN #
1	1	1
2	1	2
3	1	N-1
4	1	N

PROPRIETARY NOTE
 THIS DOCUMENT CONTAINS CONFIDENTIAL AND PROPRIETARY INFORMATION AND ALL DESIGN, MANUFACTURING, REPRODUCTION, USE, PATENT RIGHTS AND SALES RIGHTS ARE EXPRESSLY RESERVED BY SAMTEC, INC. THIS DOCUMENT SHALL NOT BE DISCLOSED, IN WHOLE OR PART, TO ANY UNAUTHORIZED PERSON OR ENTITY NOR REPRODUCED, TRANSFERRED OR INCORPORATED IN ANY OTHER PROJECT IN ANY MANNER WITHOUT THE EXPRESS WRITTEN CONSENT OF SAMTEC, INC.

DO NOT SCALE DRAWING

SHEET SCALE: 1:25:1



520 PARK EAST BLVD, NEW ALBANY, IN 47150
 PHONE: 812-944-6733 FAX: 812-948-5047
 e-Mail info@SAMTEC.com code 55322

DESCRIPTION: LSHM CABLE ASSEMBLY
 DWG. NO. HLCD-XX-XX.XX-XXX-XXX-X-X
 BY: ANDREW C 05/29/2013 SHEET 3 OF 4

FIRST END OPTION	FIRST END SUB-HLCD-XX-XX-XX-X-XX.X	WRING OPTION	FIRST END PIN #	SECOND END PIN #	SECOND END OPTION (SUB-HLCD-XX-XX-XX-X-LX.X)							
					-TRX	-TLX	-TD	-TH	-BRX	-BLX	-BD	-BH
-TRX	-XX-01-01-X-L2.5	1	1	1	-XX-02-02-X-L2.5	N/A	-XX-03-01	N/A	N/A	-XX-01-02-X-L2.5	N/A	-XX-04-02
		2	1	2	-XX-02-01-X-L2.5	N/A	-XX-03-02	N/A	N/A	-XX-01-01-X-L2.5	N/A	-XX-04-01
		3	1	N-1	N/A	-XX-01-01-X-L2.5	N/A	-XX-04-01	-XX-02-01-X-L2.5	N/A	-XX-03-02	N/A
		4	1	N	N/A	-XX-01-02-X-L2.5	N/A	-XX-04-02	-XX-02-02-X-L2.5	N/A	-XX-03-01	N/A
-TLX	-XX-02-01-X-L2.5	1	1	1	N/A	-XX-01-02-X-L2.5	N/A	-XX-04-02	-XX-02-02-X-L2.5	N/A	-XX-03-01	N/A
		2	1	2	N/A	-XX-01-01-X-L2.5	N/A	-XX-04-01	-XX-02-01-X-L2.5	N/A	-XX-03-02	N/A
		3	1	N-1	-XX-02-01-X-L2.5	N/A	-XX-03-02	N/A	N/A	-XX-01-01-X-L2.5	N/A	-XX-04-01
		4	1	N	-XX-02-02-X-L2.5	N/A	-XX-03-01	N/A	N/A	-XX-01-02-X-L2.5	N/A	-XX-04-02
-TH	-XX-04-01	1	1	1	-XX-02-02-X-L2.5	N/A	-XX-03-01	N/A	N/A	-XX-01-02-X-L2.5	N/A	-XX-04-02
		2	1	2	-XX-02-01-X-L2.5	N/A	-XX-03-02	N/A	N/A	-XX-01-01-X-L2.5	N/A	-XX-04-01
		3	1	N-1	N/A	-XX-01-01-X-L2.5	N/A	-XX-04-01	-XX-02-01-X-L2.5	N/A	-XX-03-02	N/A
		4	1	N	N/A	-XX-01-02-X-L2.5	N/A	-XX-04-02	-XX-02-02-X-L2.5	N/A	-XX-03-01	N/A
-TD	-XX-03-01	1	1	1	N/A	-XX-01-01-X-L2.5	N/A	-XX-04-01	-XX-02-01-X-L2.5	N/A	-XX-03-02	N/A
		2	1	2	N/A	-XX-01-02-X-L2.5	N/A	-XX-04-02	-XX-02-02-X-L2.5	N/A	-XX-03-01	N/A
		3	1	N-1	-XX-02-02-X-L2.5	N/A	-XX-03-01	N/A	N/A	-XX-01-02-X-L2.5	N/A	-XX-04-02
		4	1	N	-XX-02-01-X-L2.5	N/A	-XX-03-02	N/A	N/A	-XX-01-01-X-L2.5	N/A	-XX-04-01
-BRX	-XX-01-01-X-L2.5	1	1	1	N/A	-XX-01-02-X-L2.5	N/A	-XX-04-02	-XX-02-02-X-L2.5	N/A	-XX-03-01	N/A
		2	1	2	N/A	-XX-01-01-X-L2.5	N/A	-XX-04-01	-XX-02-01-X-L2.5	N/A	-XX-03-02	N/A
		3	1	N-1	-XX-02-01-X-L2.5	N/A	-XX-03-02	N/A	N/A	-XX-01-01-X-L2.5	N/A	-XX-04-01
		4	1	N	-XX-02-02-X-L2.5	N/A	-XX-03-01	N/A	N/A	-XX-01-02-X-L2.5	N/A	-XX-04-02
-BLX	-XX-02-01-X-L2.5	1	1	1	-XX-02-02-X-L2.5	N/A	-XX-03-01	N/A	N/A	-XX-01-02-X-L2.5	N/A	-XX-04-02
		2	1	2	-XX-02-01-X-L2.5	N/A	-XX-03-02	N/A	N/A	-XX-01-01-X-L2.5	N/A	-XX-04-01
		3	1	N-1	N/A	-XX-01-01-X-L2.5	N/A	-XX-04-01	-XX-02-01-X-L2.5	N/A	-XX-03-02	N/A
		4	1	N	N/A	-XX-01-02-X-L2.5	N/A	-XX-04-02	-XX-02-02-X-L2.5	N/A	-XX-03-01	N/A
-BH	-XX-04-01	1	1	1	N/A	-XX-01-02-X-L2.5	N/A	-XX-04-02	-XX-02-02-X-L2.5	N/A	-XX-03-01	N/A
		2	1	2	N/A	-XX-01-01-X-L2.5	N/A	-XX-04-01	-XX-02-01-X-L2.5	N/A	-XX-03-02	N/A
		3	1	N-1	-XX-02-01-X-L2.5	N/A	-XX-03-02	N/A	N/A	-XX-01-01-X-L2.5	N/A	-XX-04-01
		4	1	N	-XX-02-02-X-L2.5	N/A	-XX-03-01	N/A	N/A	-XX-01-02-X-L2.5	N/A	-XX-04-02
-BD	-XX-03-01	1	1	1	-XX-02-01-X-L2.5	N/A	-XX-03-02	N/A	N/A	-XX-01-01-X-L2.5	N/A	-XX-04-01
		2	1	2	-XX-02-02-X-L2.5	N/A	-XX-03-01	N/A	N/A	-XX-01-02-X-L2.5	N/A	-XX-04-02
		3	1	N-1	N/A	-XX-01-02-X-L2.5	N/A	-XX-04-02	-XX-02-02-X-L2.5	N/A	-XX-03-01	N/A
		4	1	N	N/A	-XX-01-01-X-L2.5	N/A	-XX-04-01	-XX-02-01-X-L2.5	N/A	-XX-03-02	N/A

FOR -TRX, -TLX, -BRX, -BLX ADD "S" FOR SCREW DOWN OPTION (I.E. -TLS END OPTION = SUB-HLCD-XX-02-XX-S-L2.5)

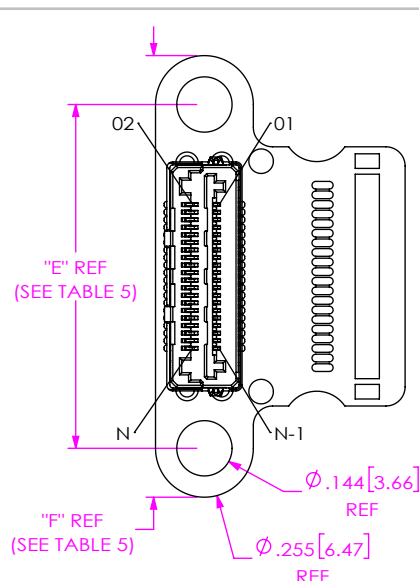

FIG. 2. VERTICAL SCREW DOWN OPTION (HLCD-20-XX.XX-TRS-XXX-X SHOWN)

No. OF POSITIONS	"E"	"F"
-005	0.600 [15.24]	0.855 [21.72]
-010	0.698 [17.73]	0.953 [24.21]
-020	0.895 [22.74]	1.150 [29.21]
-030	1.195 [30.36]	1.450 [36.83]
-040	1.495 [37.98]	1.750 [44.45]
-050	1.795 [45.60]	2.050 [52.07]

TABLE 7							
EXAMPLE SIGNAL MAPPING - HLCD-20-XX.XX-XXX-XXX-1							
END 1	1	3	5	...	35	37	39
NAME	SIG	SIG	SIG	...	SIG	SIG	SIG
END 2	1	3	5	...	35	37	39
END 1	2	4	6	...	36	38	40
NAME	SIG	SIG	SIG	...	SIG	SIG	SIG
END 2	2	4	6	...	36	38	40

LSHM SHIELD TIED TO COAX SHIELD FOR GROUND RETURN

PROPRIETARY NOTE
 THIS DOCUMENT CONTAINS CONFIDENTIAL AND PROPRIETARY INFORMATION AND ALL DESIGN, MANUFACTURING, REPRODUCTION, USE, PATENT RIGHTS AND SALES RIGHTS ARE EXPRESSLY RESERVED BY SAMTEC, INC. THIS DOCUMENT SHALL NOT BE DISCLOSED, IN WHOLE OR IN PART, TO ANY UNAUTHORIZED PERSON OR ENTITY NOR REPRODUCED, TRANSFERRED OR INCORPORATED IN ANY OTHER PROJECT IN ANY MANNER WITHOUT THE EXPRESS WRITTEN CONSENT OF SAMTEC, INC.
 DO NOT SCALE DRAWING
 SHEET SCALE: 1:25:1

samtec
 520 PARK EAST BLVD, NEW ALBANY, IN 47150
 PHONE: 812-944-6733 FAX: 812-948-5047
 e-Mail: info@SAMTEC.com code 55322

DESCRIPTION:
 LSHM CABLE ASSEMBLY

DWG. NO.
HLCD-XX-XX.XX-XXX-XXX-X-X

BY: ANDREW C 05/29/2013 SHEET 4 OF 4