

LOADING PATTERN MATING SIDE

y	6	6	6	6	6	6	6	6	6	6		6	6	6	6	6	6	6	6	6	6
h	4	4	4	4	4	4	4	4	4	4	4	4	4	4	4	4	4	4	4	4	4
g	4	4	4	4	4	4	4	4	4	4	4	4	4	4	4	4	4	4	4	4	4
f	4	4	4	4	4	4	4	4	4	4	4	4	4	4	4	4	4	4	4	4	4
e	4	4	4	4	4	4	4	4	4	4	4	4	4	4	4	4	4	4	4	4	4
d	4	4	4	4	4	4	4	4	4	4	4	4	4	4	4	4	4	4	4	4	4
c	4	4	4	4	4	4	4	4	4	4	4	4	4	4	4	4	4	4	4	4	4
b	4	4	4	4	4	4	4	4	4	4	4	4	4	4	4	4	4	4	4	4	4
a	4	4	4	4	4	4	4	4	4	4	4	4	4	4	4	4	4	4	4	4	4
z	6	6	6	6	6	6	6	6	6	6		6	6	6	6	6	6	6	6	6	6
P																					
S	01	50	10	15	20	25															

LOADED CONNECTOR ASSEMBLY (FOR EXAMPLE)

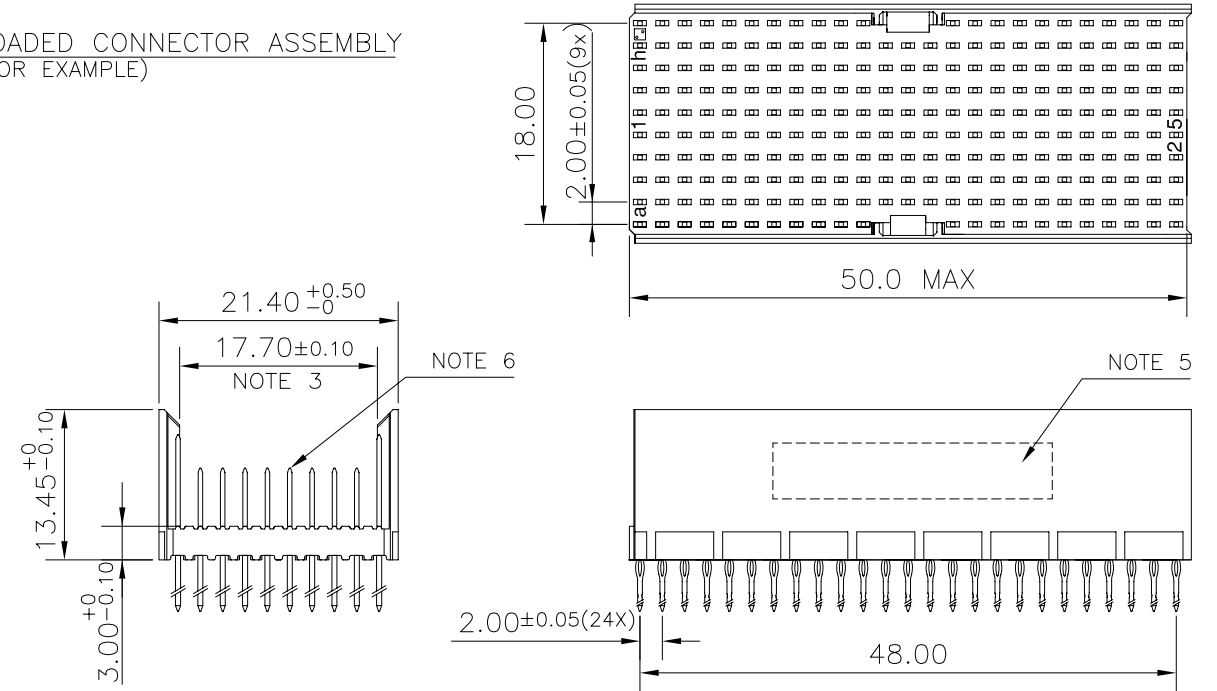

CONTACT OVERVIEW

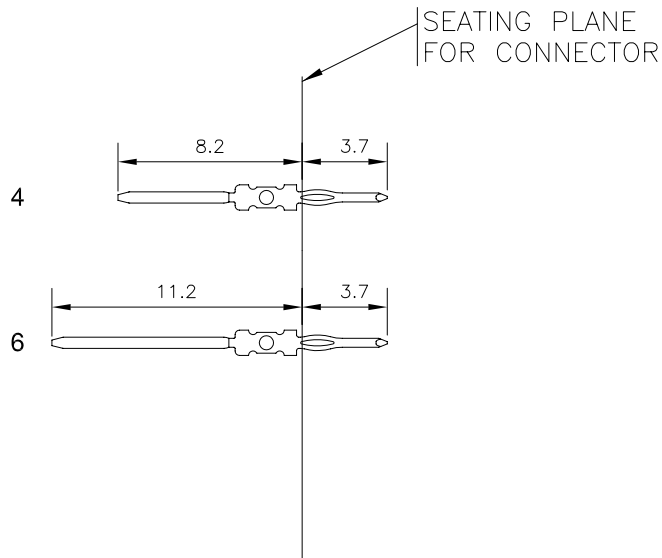

HM2P95PA8111---
 LEAD FREE INDICATOR : LF = LEAD FREE (DIGIT 15 & 16)
 PLATING CODE (DIGIT 13 AND 14)

PLATING TABLE

CODE	PLATING	CONTACT AREA	TYPE OF TERMINAL	PERFORMANCE LEVEL
AA	0.75μ Au	GOLD OVER NICKEL PLATING.	SHORT TERMINAL EON PRESSFIT CONTACTS	IEC PERFORMANCE LEVEL 2 (250 mating cycles) or TELCORDIA CO
AB	1.25μ Au	GOLD OVER NICKEL PLATING.	SHORT TERMINAL EON PRESSFIT CONTACTS	TELCORDIA UE

LAY-OUT P.C.B.-HOLE

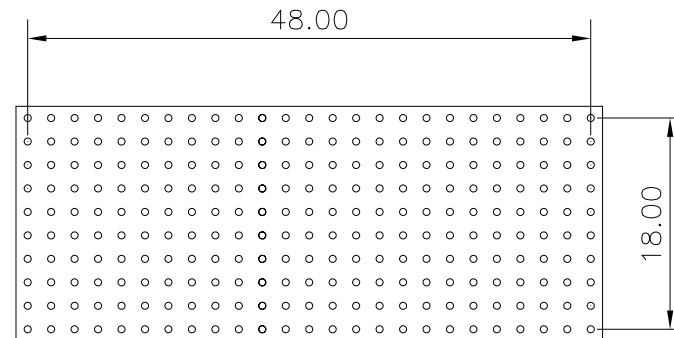

NOTES

- THIS PRODUCT IS CSA APPROVED.
 - THIS PRODUCT IS UL RECOGNIZED.
 - MEASURED AT THE BOTTOM.
 - MATERIAL CONTACT: PHOSPHOR BRONZE
HOUSING : CREAM WHITE GLASS FILLED POLYESTER UL-94V0
 - CONNECTOR PRINTED WITH P/N AND DATE CODE.
 - FOR ACTUAL CONTACT LOADINGS, SEE LOADING PATTERN MATING SIDE.
 - SHAPE OF CONNECTOR HOUSING CAN ALTER DEPENDING ON PRODUCTION LOCATION
 - THE PRODUCT (LF) MEETS EUROPEAN UNION DIRECTIVES AND OTHER COUNTRY REGULATIONS AS DESCRIBED IN GS-22-008
 - FOR RECOMMENDED PTH DIMENSIONS REFER DRAWING : BS, A , 201572 , 001
- CATALOG NO: HM2P95PA8111----

mat'l. code		SEE NOTE 4		surface	ISO 1302	tolerance	ISO 406 ISO 1101	projection	product family	MILLIPACS				
ltr		ecn no	dr	date		tolerances unless otherwise specified		MM	title					
A	109-0210	MINI		2009-10-06		angles	linear		MPACS 8+2R STR HDR PF CONN TYPE DE					
B	109-0290	AB		2009-12-29				scale						
C	110-0018	MINI		2010-01-13		0°±1°		scale						
sheet index		revision sheet	c			dr	MINI K VANDANATH		2009-10-06	dwg no		sheet 1 of 1	size	
						engr	ALEX BABU		2009-10-06	BS, C , 203032, 020		A3		
						chr	ALEX BABU		2009-10-06	type		Product	Customer	Drawing
						appd	ALEX BABU		2009-10-06					