

8

7

6

5

4

3

2

1

VICOR CONFIDENTIAL
 THIS DOCUMENT AND THE DATA DISCLOSED HEREIN OR
 HEREWITH IS NOT TO BE REPRODUCED, USED OR
 DISCLOSED IN WHOLE OR IN PART TO ANYONE WITHOUT
 THE PERMISSION OF VICOR CORP.

REV.	DESCRIPTION	DATE	APPROVED
3	RELEASED PER E090033	AR 01/09/09	REJH
4	REVISED PER E092035	JS 11/16/09	REJH
5	REDRAWN PER E100871	DCS 07/01/10	KUK
6	REVISED PER E111266	VSS 12/22/11	REJH

#4-40 UNC-2B COLD FORM TAP
 .140 DP MIN. FROM FAR SIDE
 DO NOT BREAK THRU
 (6) PL.

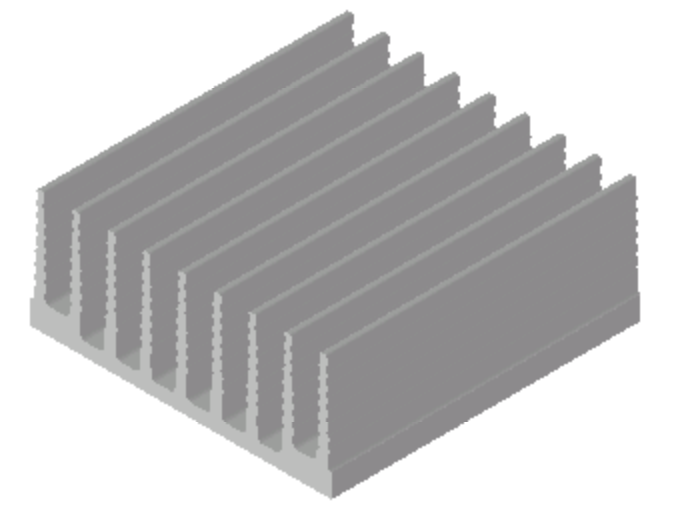
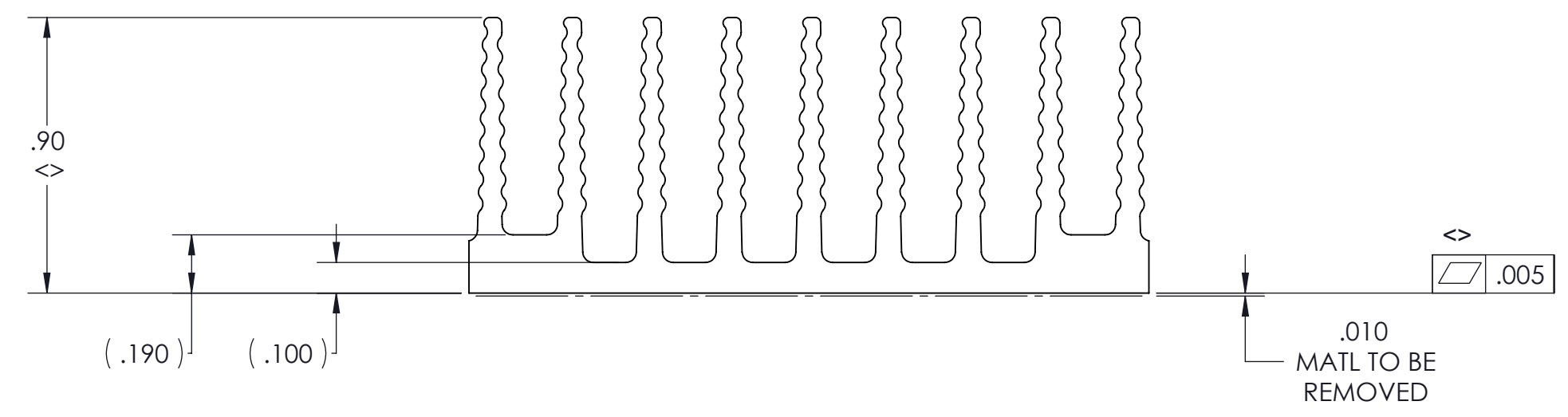
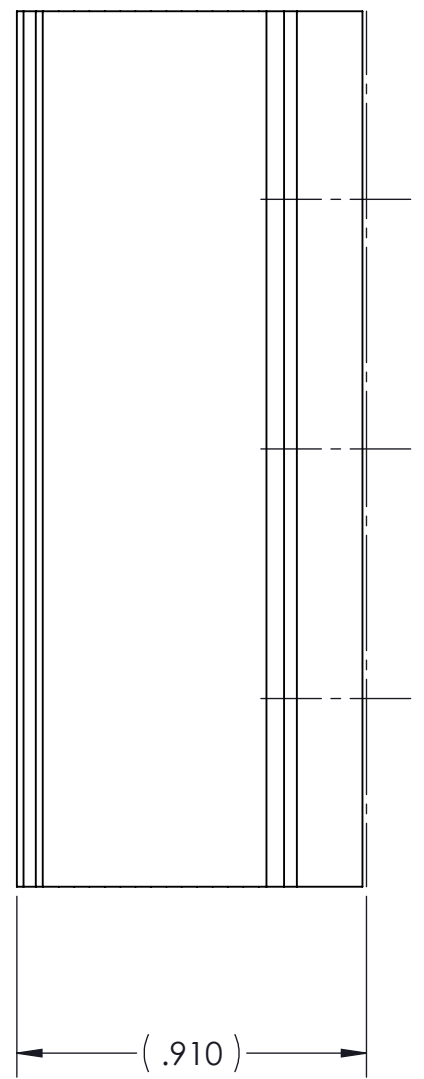
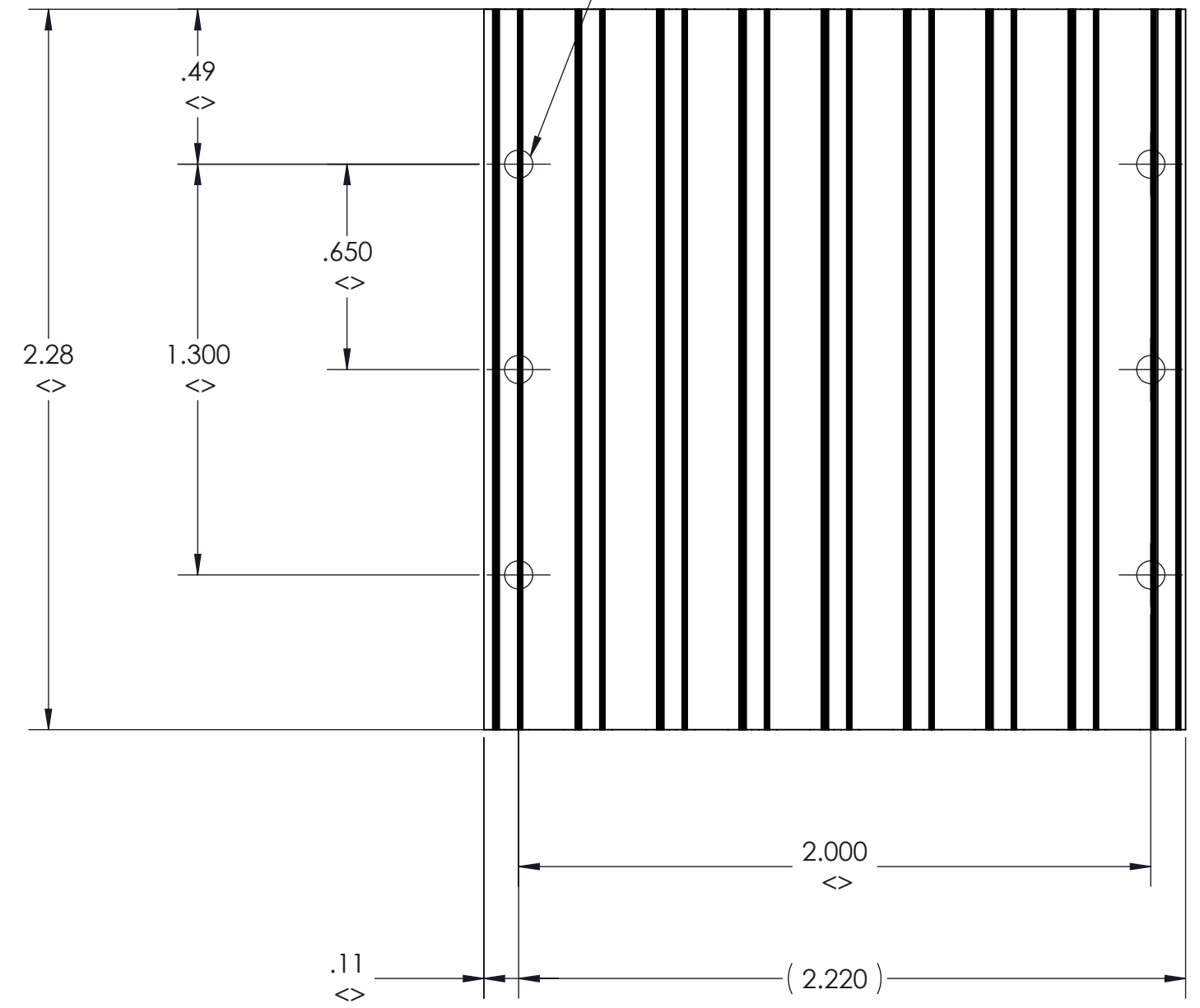

- NOTES:
1. MATERIAL: EXTRUSION SEE SHEET 2 OF 2
 2. REMOVE ALL BURRS AND SHARP EDGES.
 - <>3. CLEAR FINISH, RoHS COMPLIANT PER CST-0001, LATEST REVISION PER
 A) CHROMIUM FREE, OR
 B) TRIVALENT CHROMIUM IN ACCORDANCE WITH MIL-DTL-5541, TYPE II, CLASS 1A OR 3.
 SEE CST-0003 FOR TYPES OF AVAILABLE FINISHES.
 4. "<>" DENOTES CRITICAL CHARACTERISTIC FOR LOT INSPECTION.
 5. DIMENSIONS ARE INCHES ONLY.

DRAWN BY Robert Hickey	DATE 07/01/2010	VICOR SWD	
UNLESS OTHERWISE SPECIFIED DIMENSIONS ARE : INCH / (MM)		HTSNK "B" LONG .9H LO FLO THD	
TOLERANCES ARE: DECIMALS ANGLES X.XX [X.X] = ±0.01 [0.25] ±1° X.XXX [X.XX] = ±0.005 [0.127]		SIZE C	CAGE CODE 67131
THIRD ANGLE PROJECTION  DO NOT SCALE DRAWING		DWG NO 30189	REV 6
SCALE 2:1		SHEET 1 OF 2	

8

7

6

5

4

3

2

1

VICOR CONFIDENTIAL
 THIS DOCUMENT AND THE DATA DISCLOSED HEREIN OR
 HEREWITH IS NOT TO BE REPRODUCED, USED OR
 DISCLOSED IN WHOLE OR IN PART TO ANYONE WITHOUT
 THE PERMISSION OF VICOR CORP.

REV.	DESCRIPTION	DATE	APPROVED
	SEE SHEET 1 OF 2		

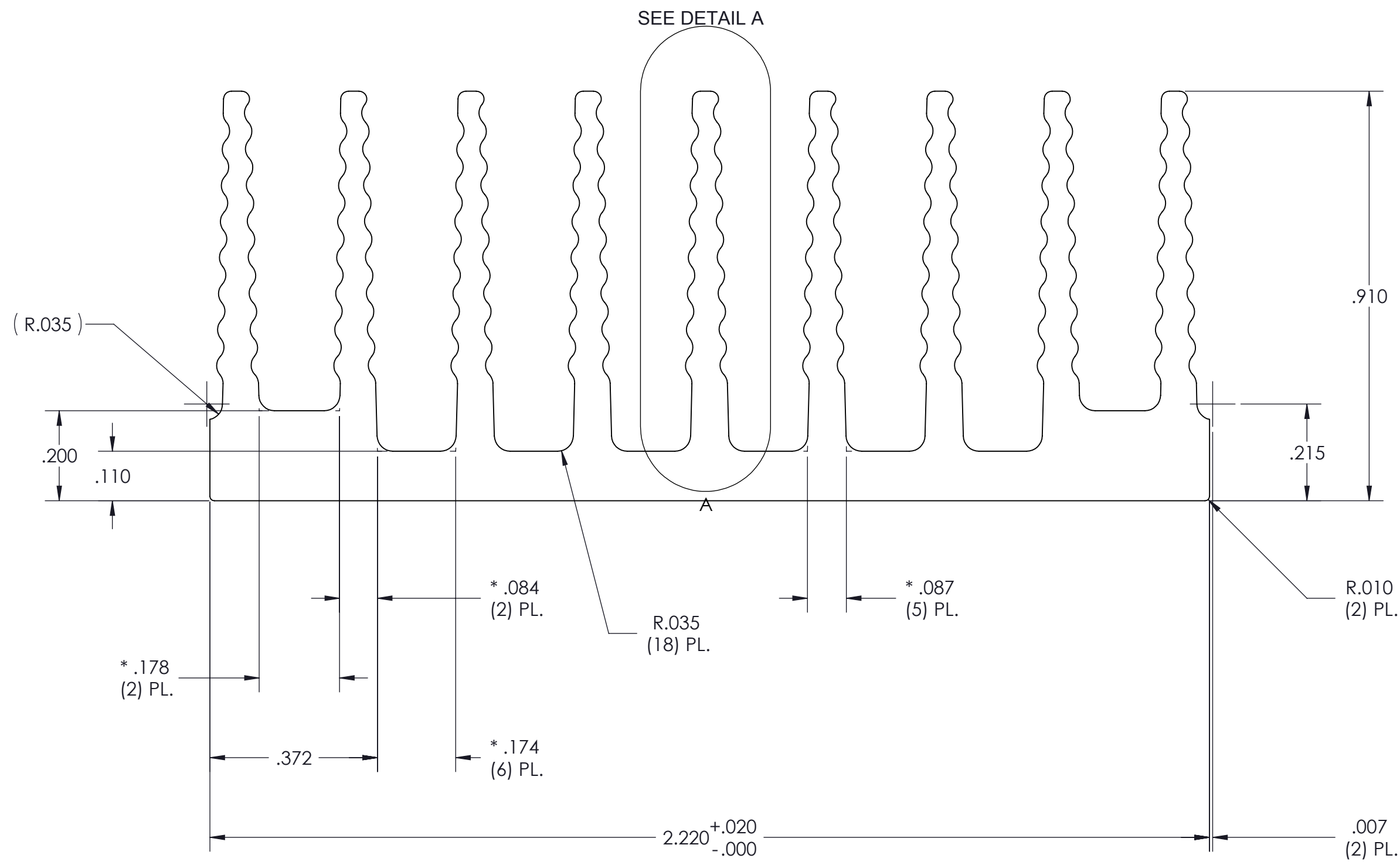

PROFILE COMMON FOR
30123
30181
30189
30182
30188

- NOTES:
1. MATERIAL: ALUMINUM 6063-T5
 2. * DENOTES DIMENSION TO THEORETICAL SHARP CORNER.
 3. ALL DIMENSIONS ARE CRITICAL CHARACTERISTICS.
 4. RoHS COMPLIANT PER CST-0001 LATEST REVISION.
 5. WORKMANSHIP STANDARDS WS-0004, WS-0006, AND WS0007 APPLY TO THIS PART.
 6. DIMENSIONS ARE INCHES ONLY.

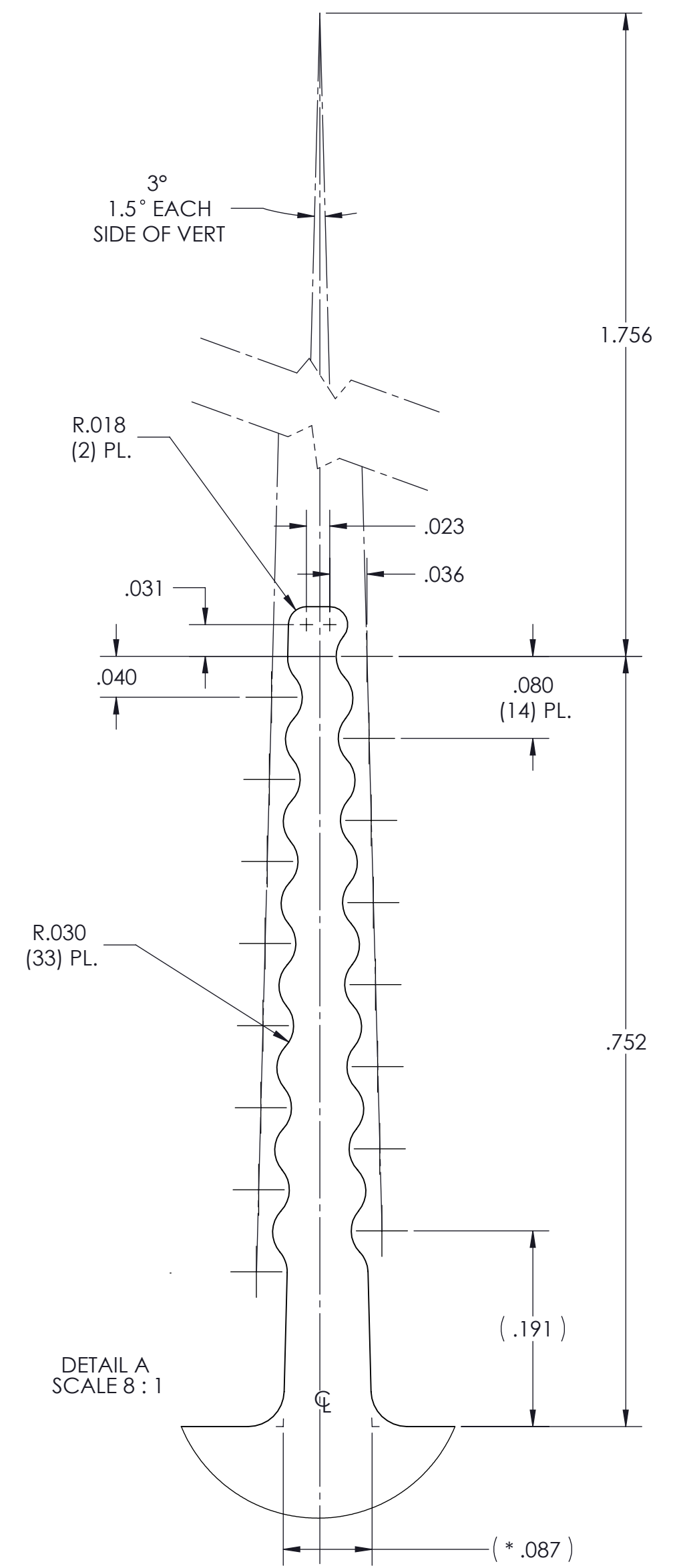

DRAWN BY Robert Hickey	DATE 07/01/2010	VICOR SWD		
UNLESS OTHERWISE SPECIFIED DIMENSIONS ARE : INCH / (MM)		HTSNK "B" LONG .9H LO FLO THD		
TOLERANCES ARE: DECIMALS ANGLES X.XX [X.X] = ±0.01 [0.25] ±1° X.XXX [X.XXX] = ±0.005 [0.127]		SIZE C	CAGE CODE 67131	DWG NO 30189
THIRD ANGLE PROJECTION 		SCALE 1:1	REV 6	
DO NOT SCALE DRAWING		SHEET 2 OF 2		