

REV.	DATE	ECR NO.	DESCRIPTION
NC	10/15/10	XXXXXX	INITIAL RELEASE
A	11/14/13	2557	CHANGE MOUNTING HARDWARE TO PASSIVATED STAINLESS STEEL, ADD ELECTRICAL/MECHANICAL NOTES, UPDATED DRAWING FORMAT

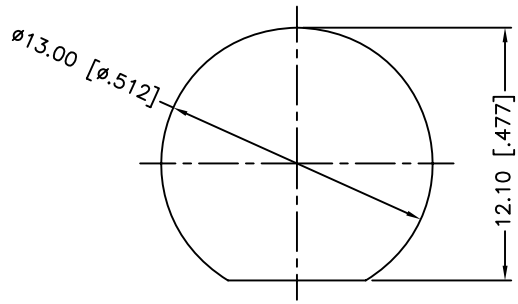

RECOMMENDED MOUNTING HOLE

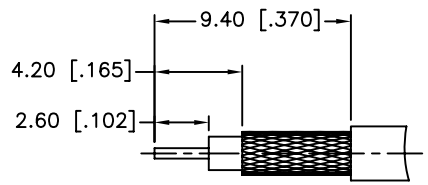

RECOMMENDED CABLE STRIPPING DIM'S

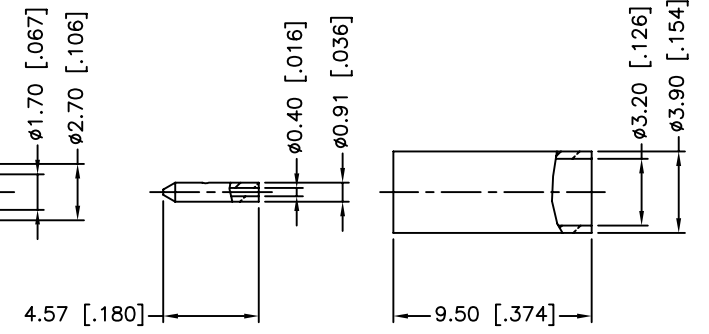
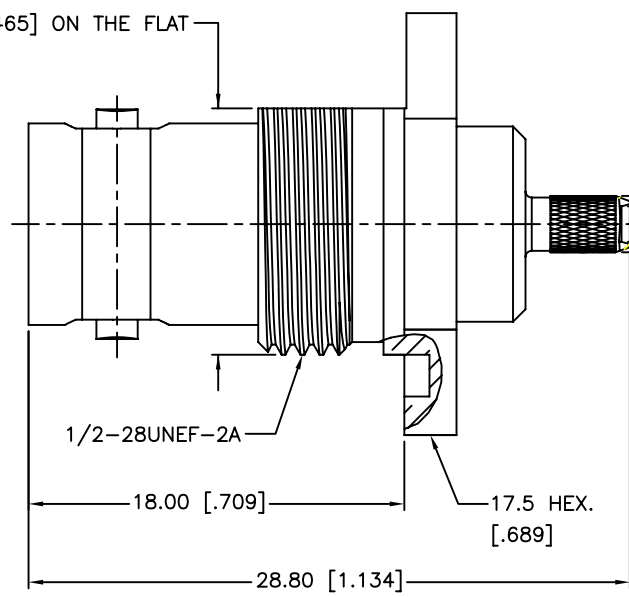
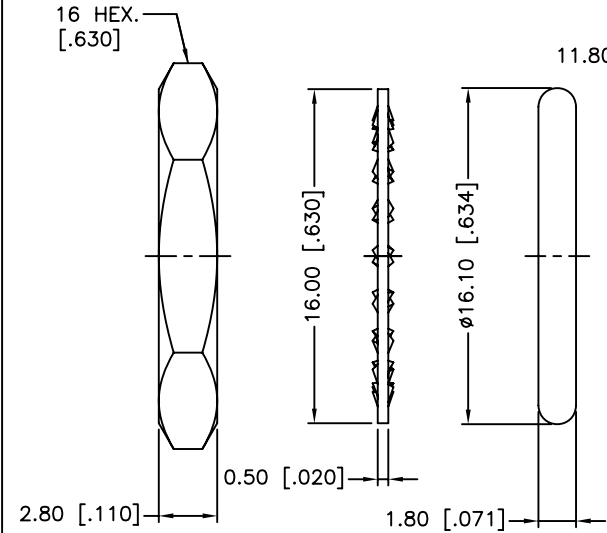
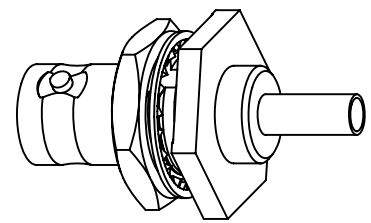

1. IMPEDANCE: 75 OHM
2. FREQUENCY RANGE: 0-2 GHZ
3. DIELECTRIC WITHSTANDING VOLTAGE: 900 VRMS, MIN.
4. DURABILITY: 500 CYCLES MIN.
5. TEMPERATURE RANGE: -65°C TO +165°C
6. CRIMPED FERRULE
HEX. CRIMP SIZE .128"
7. CRIMPED CONTACT PIN
USE 4-WAY INDENT CRIMP TOOL #47025
8. MAX. PANEL THICKNESS=3.5mm

QTY	DESCRIPTION	MATERIAL	FINISH
1	HEX NUT	STAINLESS STEEL	PASSIVATED
1	LOCK WASHER	STAINLESS STEEL	PASSIVATED
1	GASKET	SILICONE RUBBER	RED
1	FERRULE	BRASS	NICKEL
1	CONTACT PIN	BRASS	GOLD
1	RETAINING RING	BRASS	NICKEL
1	CONTACT PIN	PHOSPHOR BRONZE	GOLD
1	GASKET	SILICONE RUBBER	RED
1	INSULATOR	PTFE	NATURAL
1	BODY	BRASS	NICKEL
QTY	DESCRIPTION	MATERIAL	FINISH

UNLESS OTHERWISE SPECIFIED DIMENSIONS ARE IN MILLIMETERS. DIMENSIONS IN [] ARE IN INCHES AND FOR CUSTOMER REFERENCE ONLY.
 TOLERANCES FOR MILLIMETERS ARE:
 <0.5 ± 0.05mm
 0.5 - 6mm ± 0.10mm
 6 - 30mm ± 0.20mm
 30 - 120mm ± 0.30mm
 ANGLES ± 1°
 UNLESS OTHERWISE SPECIFIED TOLERANCES FOR INCHES ARE:
 <.020 ± 0.002"
 .020 - .236 ± 0.004"
 .236 - 1.180 ± 0.007"
 1.180 - 4.724 ± 0.012"
 ANGLES ± 1°
 DO NOT SCALE DRAWING

APPROVALS	DATE
DRAWN M.ZHANG	11/14/13
CHECKED	
ISSUED	
SHEET 1 OF 1	
CAD FILE C:/CONNEX/112235-12.DWG	

Amphenol Connex

**75 OHM BNC BULKHEAD CRIMP JACK
IP-67 COMPLIANT (FOR RG-179/U CABLE)**

PART NO. **112235-12**

DWG. NO. 112235-12.DWG REV. A SIZE A SCALE NA