



FCconnect.com

Copyright FCJ

1

2 3

4

5

6

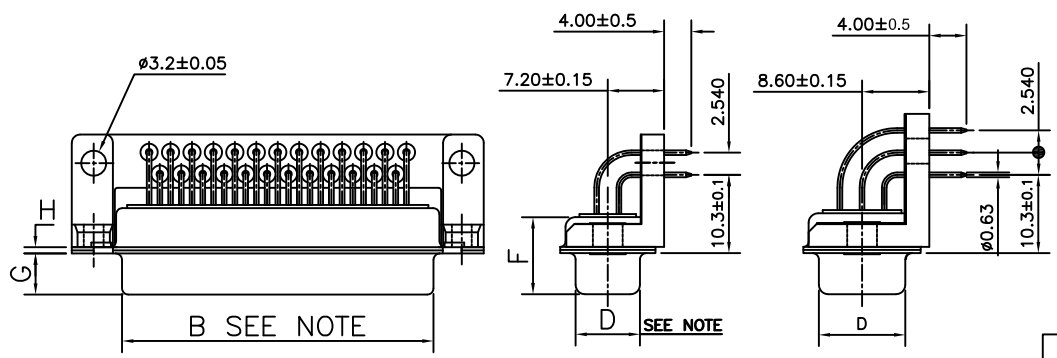

50	P	66.65	52.68	61.11	11.08	14.99	11.09	5.85	1.0
	S	66.65	52.30	61.11	10.62	14.99	11.21	6.05	0.8
37	P	68.94	55.30	63.50	8.23	12.17	11.09	5.85	1.0
	S	68.94	54.71	63.50	7.77	12.17	11.21	6.05	0.8
25	P	52.65	38.84	47.04	8.23	12.17	11.09	5.85	0.8
	S	52.65	38.25	47.04	7.77	12.17	11.21	6.05	0.8
15	P	38.76	25.12	33.32	8.23	12.17	10.99	5.85	0.8
	S	38.76	24.54	33.32	7.77	12.17	11.21	6.05	0.8
09	P	30.43	16.79	24.99	8.23	12.17	10.99	5.85	0.8
	S	30.43	16.21	24.99	7.77	12.17	11.21	6.05	0.8
SHELL SIZE		+0.76 A-0	+0.25 B-0	±0.12 C	+0.25 D-0	+0.76 E-0	F MAX	+0.15 G-0	+0.22 H-0

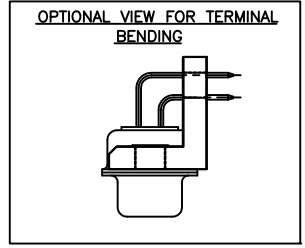

TECHNICAL SPECIFICATIONS

SHELLS	:	STEEL, TIN PLATED
INSULATOR MATERIAL	:	SELF EXTINGUISHING THERMOPLASTIC UL CLASS 94 V0
CONTACTS DIA ON ACTIVE AREA	:	Ø1 MM.
CONTACTS MATERIAL	:	COPPER ALLOY
CONTACT PLATING	:	GOLD OVER NICKEL
OPERATING TEMPERATURE	:	-55°C +125°C
OPERATING CURRENT	:	7.5 A PER CONTACT
CONTACT RESISTANCE	:	≤7.3mΩ
INSULATION RESISTANCE	:	>5000 MΩ
MAXIMUM VOLTAGE	:	1000 V.r.m.s
MECHANICAL ENDURANCE	:	500 MATINGS
DAMP HEAT	:	21 DAYS FOR PLATING CODE 64 56 DAYS FOR PLATING CODE 65

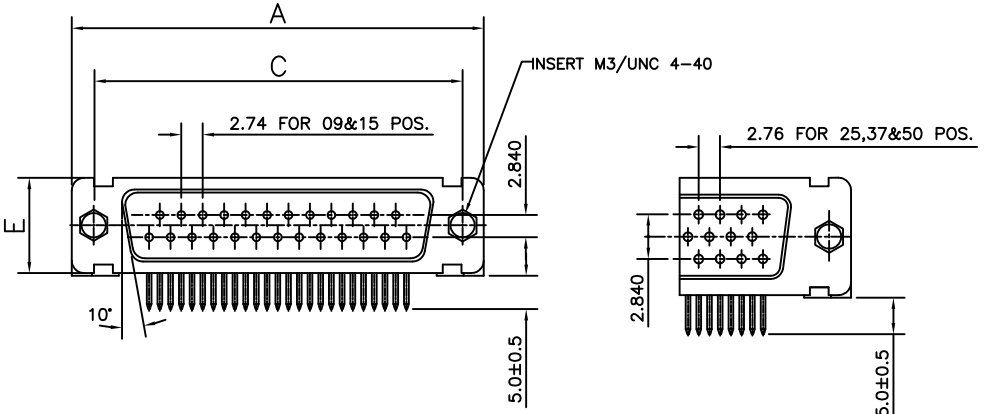

LAYOUT OF 50 POS. CONNECTOR

ORDERING INFORMATION

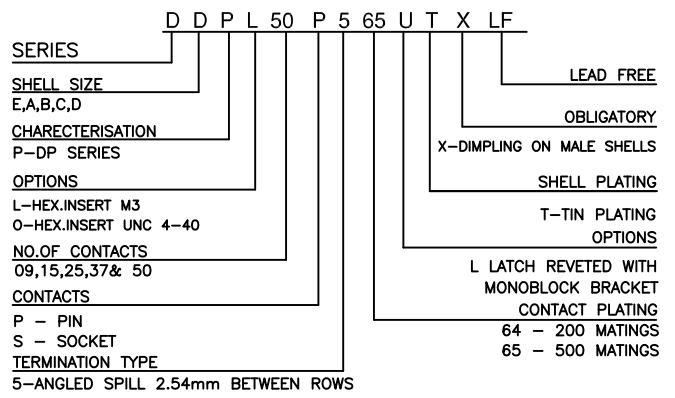

"This LF product meets European Union Directives and other country regulations as described in GS-47-0004."
 The housing will withstand exposure to 260°C peak temperature for 3.5 seconds in a wave solder application with a 1.6mm minimum thick circuit board.
 Packaging as per GS-14-920

- NOTE:
 1) INSIDE DIMENSION OF MALE AND OUTSIDE DIMENSION OF THE FEMALE CONNECTOR
 2) REFER DRG: C-DSUB-0186 FOR PCB LAYOUT

mat'l. code	-	surface	ISO 1302	tolerance	ISO 406 ISO 1101	projection	product family	D-SUB	
ltr	ecn no	dr	date	tolerances unless otherwise specified		MM	title	MALE A/S CONNECTOR UT VERSION	
B	107-0025	GVJ	2007/02/14	angles	linear				.00±.06
C	ELX-I-20760	MP	2015/05/02	0°±2'		scale	dwg no	sheet 1 of 1	
				dr	MINI K VANDANATH	2003/01/24	FCJ	C01-8637-1606	
				engr	MITHUN PAUL	2015/05/02			A3
				chr	ALIAS BABU	2015/05/02			
				appd	BIJU K PAUL	2015/05/02			type
sheet index	revision	C	1						