

DESCRIPTION

The EV3410DJ-00A is a MP3410 evaluation board that is configured to provide a regulated 3.3V output at up to 300mA from a 1.8V input or higher. The output voltage is adjustable from V_{IN} to 6V by changing resistors on the evaluation board.

The high 500kHz switching frequency of the MP3410 allows for smaller external components, producing a compact solution for a wide range of load currents. The internal compensation and soft-start features further reduce the component count. The P-Channel synchronous rectified switch improves efficiency and isolates the output from the input in a shutdown condition.

ELECTRICAL SPECIFICATIONS

Parameter	Symbol	Value	Units
Input Voltage	V_{IN}	1.8 – 3.0	V
Output Voltage	V_{OUT}	3.3	V
Output Current	I_{OUT}	300	mA

FEATURES

- 1.8V Minimum Input Voltage
- 3.3V Output Voltage, Adjustable from V_{IN} up to 6V
- Output Disconnect at Shutdown Mode
- 500kHz Switching Frequency
- 0.1 μ A Shutdown Current
- Fully Assembled and Tested

APPLICATION EXAMPLES

- MP3 Players
- Digital Still and Video Cameras
- Portable Electronics Using 2-3 Alkaline Cells or Li-Ion Batteries

"MPS" and "The Future of Analog IC Technology" are Registered Trademarks of Monolithic Power Systems, Inc.

EV3410DJ-00A EVALUATION BOARD



(L x W x H) 2.4" x 2.4" x 0.4"
(6.2cm x 6.2cm x 1.1cm)

Board Number	MPS IC Number
EV3410DJ-00A	MP3410DJ

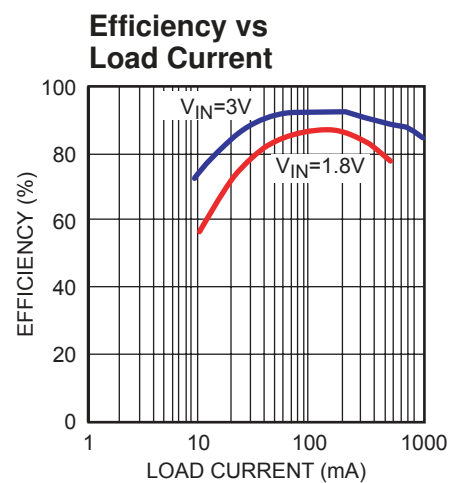

EVALUATION BOARD SCHEMATIC

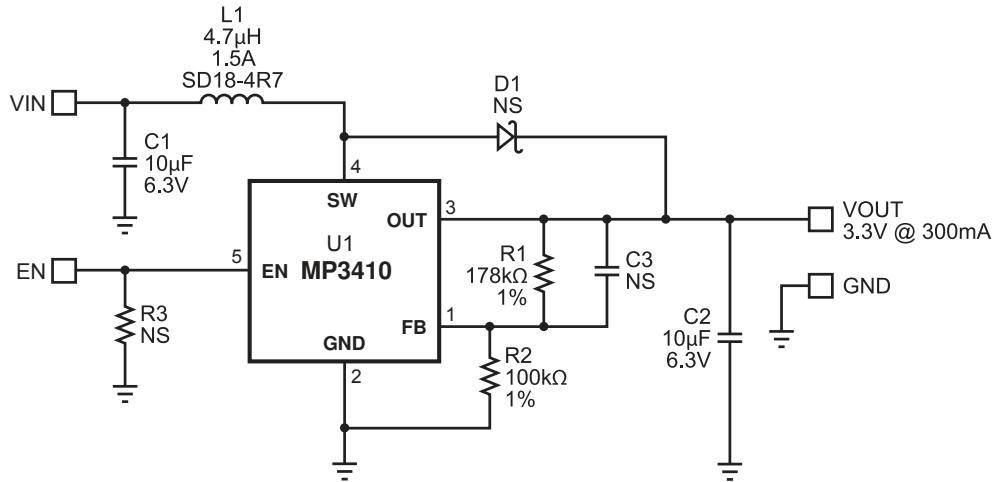

EV3410DJ-00A BILL OF MATERIALS

Qty	Ref	Value	Description	Package	Manufacturer: Part No.	Distributor: Part No.
2	C1,C2	10µF	Ceramic Capacitor, 6.3V, X5R	1206	TDK: C3216X5R0J106K	Digikey: 445-1388-1-ND
1	C3		Not Stuffed			
1	D1		Not Stuffed			
1	L1	4.7µH	Inductor, 1.5A, SMD, Unshielded		Cooper: SD18-4R7	
1	R1	178kΩ	Resistor, 1%	0805	Panasonic: ERJ-6GEYJ1783V	Digikey: P178KCCT-ND
1	R2	100kΩ	Resistor, 1%	0805	Panasonic: ERJ-6GEYJ104V	Digikey: P100KCCT-ND
1	R3		Not Stuffed			
1	U1		MP3410	TSOT23-5	MP3410	

PRINTED CIRCUIT BOARD LAYOUT

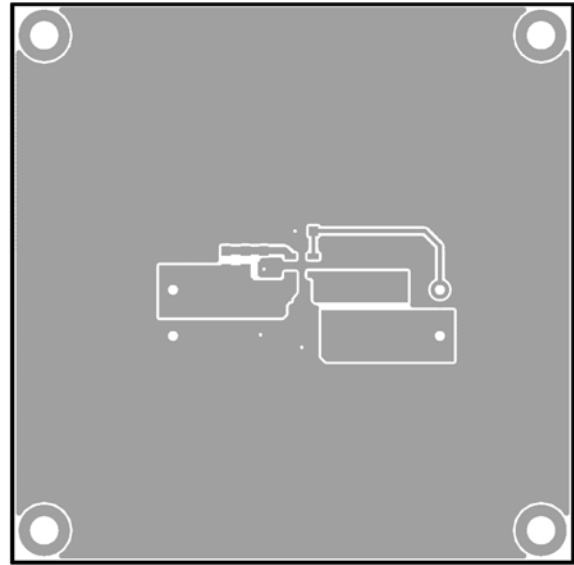
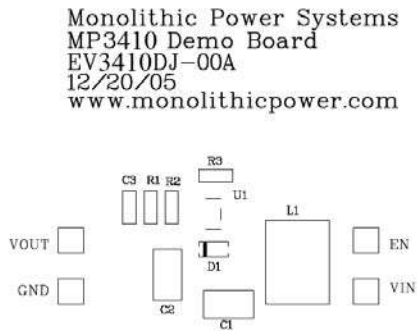

Figure 1—Top Silk Layer

Figure 2—Top Layer

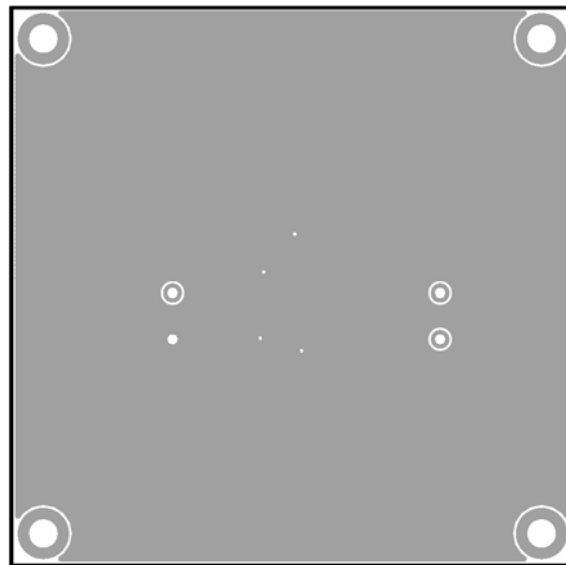

Figure 3—Bottom Layer

QUICK START GUIDE

The output voltage of this board is set to 3.3V. The board layout accommodates most commonly used inductors and output capacitors.

1. Preset Power Supply to $1.8V \leq V_{IN} \leq 3.0V$.
2. Turn Power Supply off.
3. Connect Power Supply terminals to:
 - Positive (+): VIN, EN
 - Negative (-): GND
4. Connect Load to:
 - Positive (+): VOUT
 - Negative (-): GND
5. Turn Power Supply on after making connections.
6. The MP3410 is enabled on the evaluation board once V_{IN} is applied. To disable the MP3410, disconnect EN from VIN.
7. The output voltage V_{OUT} can be changed by varying R1. Calculate the new value using the formula:

$$R1 = \left(\frac{V_{OUT}}{V_{FB}} - 1 \right) \times R2$$

Where $V_{FB} = 1.2V$ and $R2 = 100k\Omega$

For example, for $V_{OUT} = 5V$

$$R1 = \left(\frac{5V}{1.2V} - 1 \right) \times 100k\Omega = 316.7k\Omega$$

Therefore use a 316k Ω standard 1% value.

For output voltages greater than 4V, it is recommended an external Schottky diode, such as MBR0520L, be placed in parallel with the internal P channel MOSFET (with the anode connected to SW and the cathode to OUT).

NOTICE: The information in this document is subject to change without notice. Please contact MPS for current specifications. Users should warrant and guarantee that third party Intellectual Property rights are not infringed upon when integrating MPS products into any application. MPS will not assume any legal responsibility for any said applications.