



FEATURES

- Wide input voltage range, 32~96V
- 500W Output
- Full Load Efficiency up to 88% @48Vin and 72Vin
- Parallel Connection of multiple units
- Box type package with metal base plate
- Package Dimension:
198.0x113.0x45.0mm (7.80"x4.45"x1.77")
- Operating Temperature Range - 40°C to +90°C
- Input Reverse Polarity Protection
- Input UVLO, Output OCL, Short circuit protection, OVP, OTP
- Enable on/off
- 2250VDC Isolation
- IP67 protection(With fully assembled mating connector)
- RoHs Compliant
- ISO 9001, ISO 14001 certified manufacturing facility
- IEC/EN/UL60950-1, IEC/EN/UL62368-1, CE Mark
- EMC compatible: EN12895-2015, EN55011, EN55014-2, CISPR11 ClassA

The B70SP12440 (A code without parallel function,B code with parallel function), a wide input voltage range of 32~96V, and single isolated output converter, is the latest product offering from a world leader in power systems technology and manufacturing — Delta Electronics, Inc. Such box type DCDC converter can provide 500W, 12.4V regulated DC output voltage with full load efficiency up to 88% @72Vin; The B70SP12440 offers input UVLO, output over current limit, short circuit, output over voltage, over temperature, and input reverse polarity protections. It has parallel function; and allows a wide operating temperature range of -40°C to +90°C. With creative design technology and optimization of component placement, this converter possess outstanding electrical and thermal performance, as well as high reliability under extremely harsh operating conditions. The B70SP12440 meets IP67 protection (refer to "water protection level" specification).

INPUT CHARACTERISTICS

Item	Condition	Min.	Typ.	Max.	Unit
Continuous Input Voltage		32	48	96	VDC
Input Under-Voltage Lockout, Turn-On Voltage Threshold		29	30	31	VDC
Input Under-Voltage Lockout, Turn-Off Voltage Threshold		27	28	29	VDC
Lockout Hysteresis Voltage		1	2	3	VDC
Maximum Input Current	Vin=32V, 100% Load		18	19	A
No-Load Input Current	Vin=48V		80		mA
	Vin=72V, 80V		40		mA
Off converter input current	Vin=48V, enable off		6		mA
Reflected input ripple current	Vin=48V, peak to peak			0.2	A
Max Reverse Polarity Input Voltage				96	VDC
Max Inrush current				10	A
Internal Input Fuse				500V/30A Fast-acting fuse	

OUTPUT CHARACTERISTICS

Item	Conditions	Min.	Typ.	Max.	Unit
Operating Output Current Range	For A code	0		40	A
	For B code	0		42.5	A
Output Voltage Set Point	for A code	Io=0	12.4		V
		Io=40	12.4		V
	for B code	Io=0	13.25		V
		Io=42.5	11.65		V
Output Voltage Ripple and Noise,	Vin=48V, Io=100%, peak to peak, 20MHz bandwidth, Co=1μF ceramic, 10μF tantalum		120	240	mV
	Vin=48V, Io=100%, RMS, 20MHz bandwidth, Co=1μF ceramic, 10μF tantalum		35	70	mV
	Vin=72V, 80V, Io=100%, peak to peak, 20MHz bandwidth, Co=1μF ceramic, 10μF tantalum		140	280	mV
	Vin=72V, 80V, Io=100%, RMS, 20MHz bandwidth, Co=1μF ceramic, 10μF tantalum		45	90	mV
Output Current Limit			50		A
Current share accuracy	42.5A for each module, ,only for B code		10	15	%
Start-up time(start _up time by Vin)	Vin=48V,full load, from Vin=Turn-on Threshold to 10%Vo		650	800	mS
Start-up time(start _up time by Enable)	Vin=48V,full load, from Enable=ON to 10%Vo		250	400	mS
Rise time	From 10%Vo to 90%Vo		160	300	mS
Output Voltage Protection			17		V
Output Voltage Current Transient	Positive voltage step, 50% to 75% load dynamic, 0.1A/us slew rate		250	500	mV
	Negative voltage step, 50% to 75% load dynamic, 0.1A/us slew rate		250	500	mV
Maximum Output Capacitance				10000	μF
Output overshoot				3	%
Efficiency @ 100% Load	Vin=48V		88.2		%
Efficiency @ 100% Load	Vin=72V		88		%
Efficiency @ 60% Load	Vin=48V		89		%
Efficiency @ 60% Load	Vin=72V		88.5		%

GENERAL CHARACTERISTICS

Item	Conditions	Min.	Typ.	Max.	Unit
Isolation Voltage,	Input to Output, Input to Case			2250	VDC
	Output to Case			550	VDC
Isolation Resistance, Input to Output		10			MΩ
Isolation Capacitance, Input to Output			5000		pF
Switching Frequency			175		KHz
Operating life	Baseplate @ 40° C, include Aluminum capacitor			131400	Hours
MTBF	72Vin, Baseplate @ 85°C	121450			Hours
Weight			1300		g

ENVIRONMENTAL SPECIFICATIONS

Parameter	Conditions	Min.	Max.	Unit
Storage Temperature Range		-40	+105	°C
Operating Temperature Range	Baseplate	-40	+90	°C
Over Temperature Protection	NTC Temperature		118	°C
Humidity (non condensing)			95	% RH
Thermal Shock Test	Temperature range:-40~125 °C Thermal rate: 20°C /min Dwell time : 60mins Total cycle: 300cycles			ISO 16750-4
Submersion test	Total cycles : 10 Dwell time at Tmax : 1h Transition duration : <20s Testfluid : De-ionized water,5% NaCl Water Temperature:< 4°C Immersion Time : 5 mins			ISO 16750-4
Water Protection Level	With fully assembled mating connector			IP67
Vibration	Sine wave 1.Frequency (Hz) amplitude acceleration 5 – 9 HZ ±15 mm 15-200 HZ 10G 2. Sweep rate 1 Oct / min. 3. Duration 50 Cycles.			IEC 60068-2-6: Sine-wave vibration, test Fc
Mechanical Shock	50G/11ms 3Shocks for each direction			IEC 60068-2-27: Shock, half sine, test Ea:
Bump	40G/6ms 1000 Shocks for each direction			IEC 60068-2-29: Bump, test Eb:
Salt Spray Test	Operating /no load 1. Salt Spray Concentration:5%; 2. Test Temperature:35°C; 3. Volume of spray:1~2ml/hour/80cm ² ; 4. PH:6.5~7.2; 5. Test Time:96hours 6. Tolerance: Salt Spray Concentration (±1%); Test Temperature: ± 2°C;			IEC 60068-2-11:Test Ka
Emission	30-1000MHz 34-45dBuV/m			EN12895-2015
Immunity	20V/m /27-1000MHz AM; 3V/m /1-2GHz AM; 1V/m /2-2.7GHz AM EN12895-2015,			EN61000-4-3
ESD	Direct: ±8KV; Air: ±15KV EN12895-2015,			EN61000-4-2

NOTES

- 1 Specifications typical at Ta=+25°C, nominal input voltage and rated full load output current unless otherwise noted.
- 2 Specifications are subject to change without notice.

ELECTRICAL CURVES

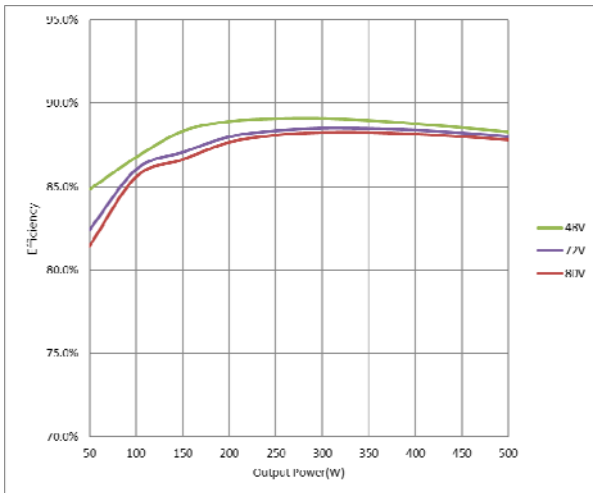

Figure 1: Efficiency vs. Output Power
@ Vin=48V,72V,80V

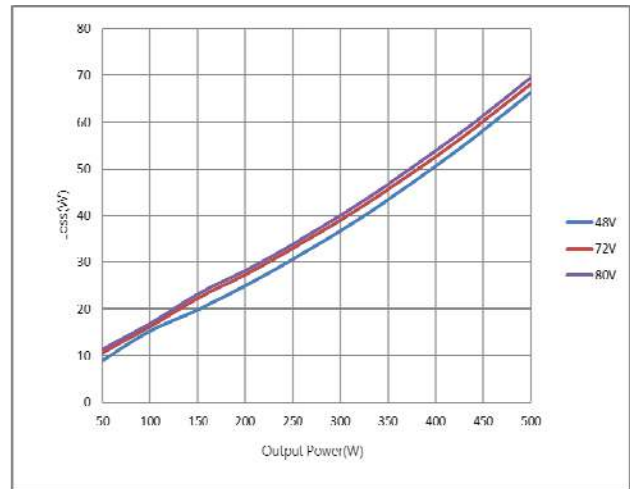

Figure 2: Loss vs. Output Power
@ Vin=48V,72V,80V

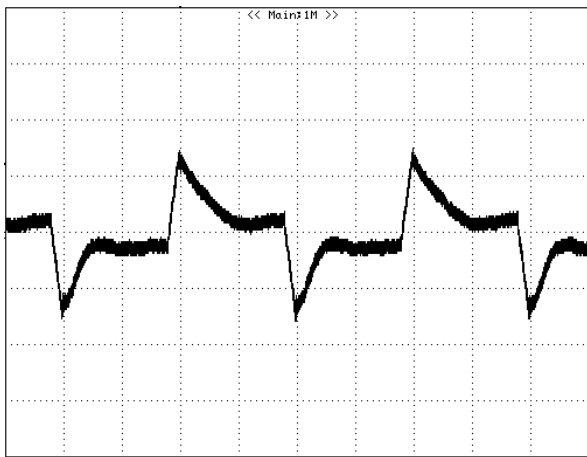

Figure 3: Dynamic response to load step 50% to 75%
with 0.1A/uS slew rate at 72Vin
CH1:VOUT, 100mV/div, 500uS/div

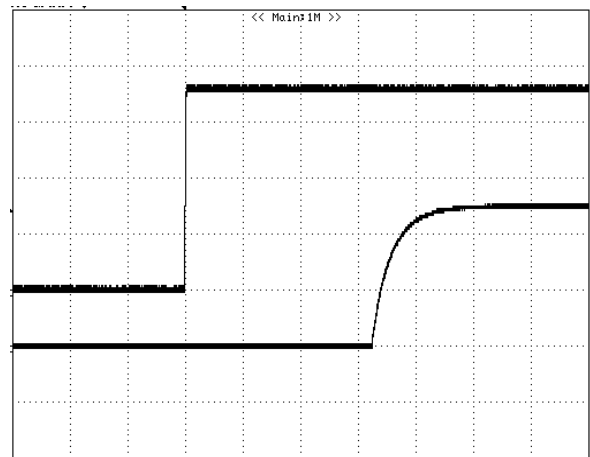

Figure 4: Vout start up with Vin on at 72Vin, 100% lout,
TOP:VIN, 20V/div, 200mS/div
BOTTOM: VOUT, 5V/div, 200mS/div

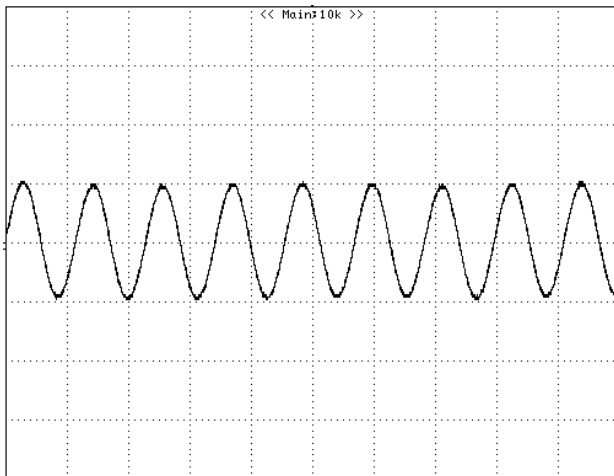

Figure 5: Output ripple & noise at 72Vin, 100% lout
CH1:VOUT, 10mV/div, 5uS/div

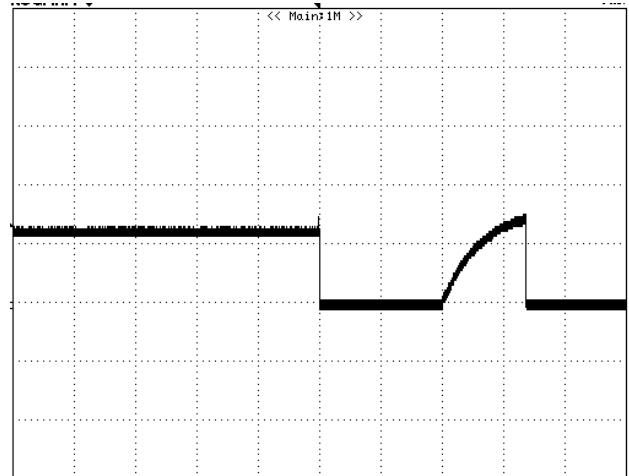

Figure 6: Output over voltage protection at 72Vin, 100% lout
CH1:VOUT, 10V/div, 100mS/div

ELECTRICAL CURVES (continuous)

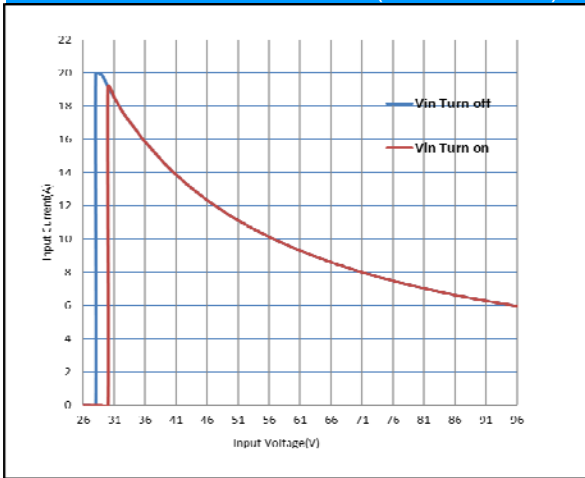

Figure 7: Input current vs. Input voltage @ Full load

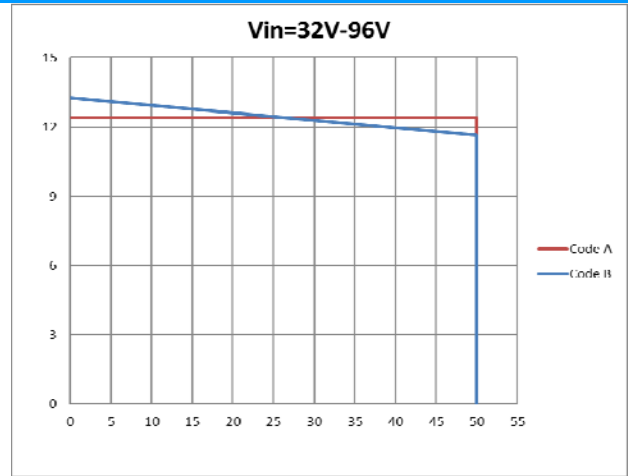

Figure 8: Output voltage vs. Output current OCL Performance

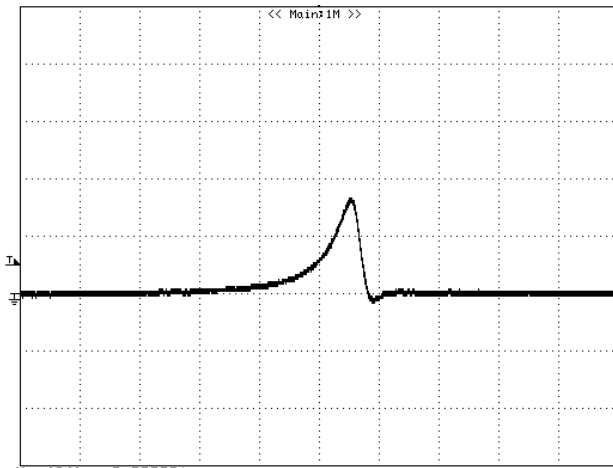

Figure 9: Inrush current @ $V_{in}=72V$
CH1: i_{in} , 2A/div, 200nS/div; Max current 3.4A

Output Over-Current Limit and Short Protection

The modules include internal output over-current limit (OCL) and short circuit protection (SCP) circuits, the OCL set point is lower than that of the SCP; The response of SCP circuit is much fast than that of the OCL circuit. The slowly increase of the output current will let module enter OCL protection when the current exceeds the OCL set point, while the fast increase of the output current will let module enter SCP when the current exceeds the SCP set point.

When the modules enter OCL protection, the output voltage will decrease while the output current is kept constant, the output voltage will soft start to set point when the overload condition is removed.

The module will enter hiccup mode when it triggers the SCP set point. The module will try to restart after shutdown. If the overload condition still exists, the module will shut down again. This restart trial will continue until the overload condition is removed.

Output Over-Voltage Protection

The power module includes an internal output over-voltage protection(OVP) circuit, which monitors the voltage on the output terminals. If this voltage exceeds the OVP set point, the module will shut down, and then restart after a fixed delay time (hiccup mode), please refer to figure6 for detail.

Over-Temperature Protection

The over-temperature protection consists of circuitry that provides protection from thermal damage. If the temperature exceeds the preset temperature threshold the module will shut down, and all components will not exceed their absolute maximum temperature ratings. The module will restart after the temperature is within specification.

Remote On/Off

B70SP12440A/B has Enable control function. This Enable PIN is designed on the primary side of converter, the converter will turn on when the Enable PIN connected to VIN+ or floating, and turn off when the Enable PIN connected to VIN-.

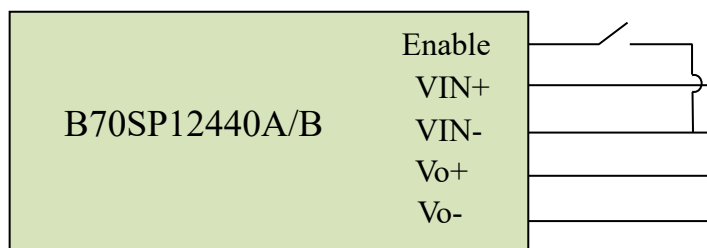

Figure 10: suggested Enable connection

Input Reverse Voltage Protection

The input reverse voltage protection is provided by an diode on the input line, the standoff voltage for the reverse protection shall be no less than -96V.

Parallel connection of multiple units(only for B code)

Two units parallel operation is verified, please contact Delta if more than two units need to be paralleled. While paralleling multiple units, the impedance of the cables from unit to junction point of each unit should be within $\pm 5\%$ of each other. Before all the parallel module finished start up, the total load current should be lower than the rated current of 1 module.

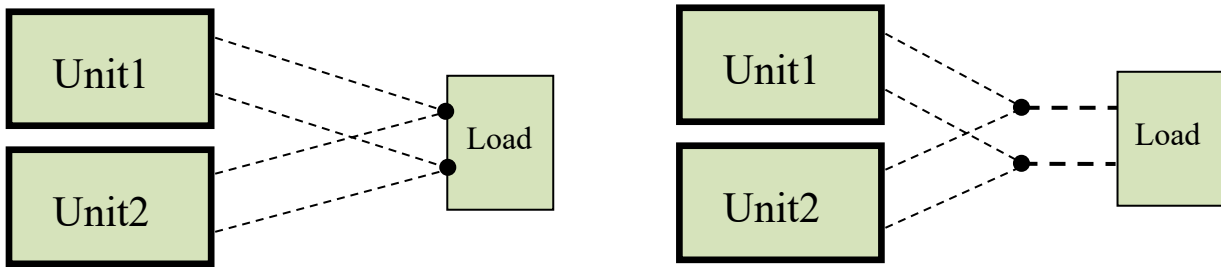

Figure 11: suggested parallel connections

THERMAL CONSIDERATION

The thermal curve is based on the test setup shown as figure12. The module is mounted on an liquid cooling plate and cooled by cooling liquid(It can also be air cooling with heatsink at client side).

Figure13 shows the location to monitor the temperature of the module's baseplate. The baseplate temperature in thermal curve is a reference for customer to make thermal evaluation and make sure the module is operated under allowable temperature. (Thermal curves shown in Figure14 are based on different input voltage).

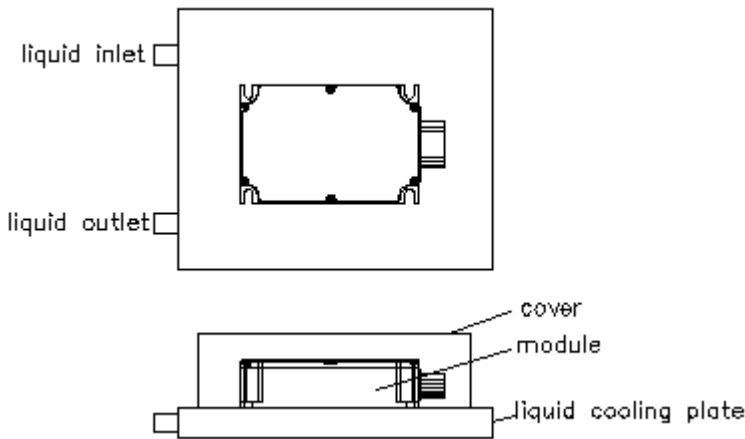

Figure 12 Test setup

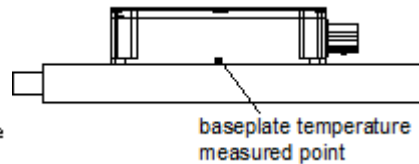

Figure 13 Temperature measured point

THERMAL CURVE

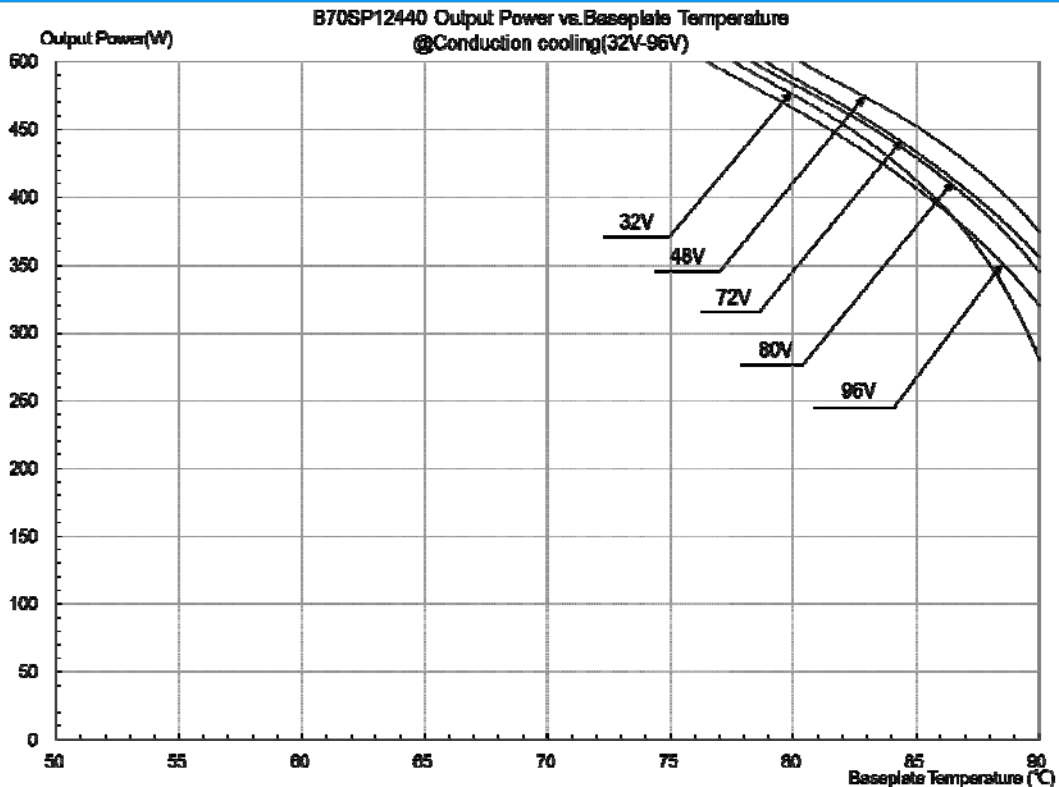
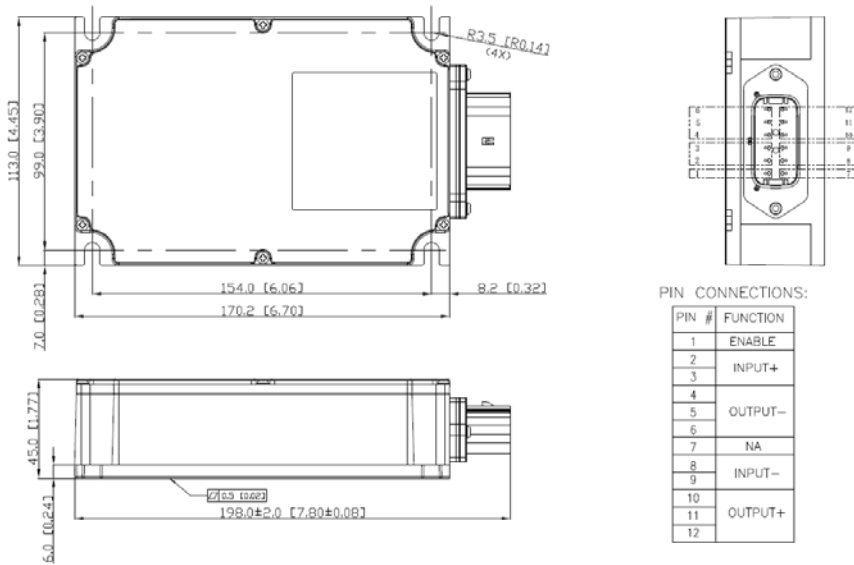

Figure 14: Output Power vs. baseplate temperature

MECHANICAL DRAWING

Mechanical Dimensions



- All dimensions in mm (inches)
- Tolerance: X.X±0.5 (X.XX±0.02)
X.XX±0.25 (X.XXX±0.010)
- Connector:
MOLEX P/N : 19429-0047
(mating connector:
housing :molex 0194180027 X1
terminal: 0194200001 X11
plug :194170119 X1
Pin7 need fill with plug)

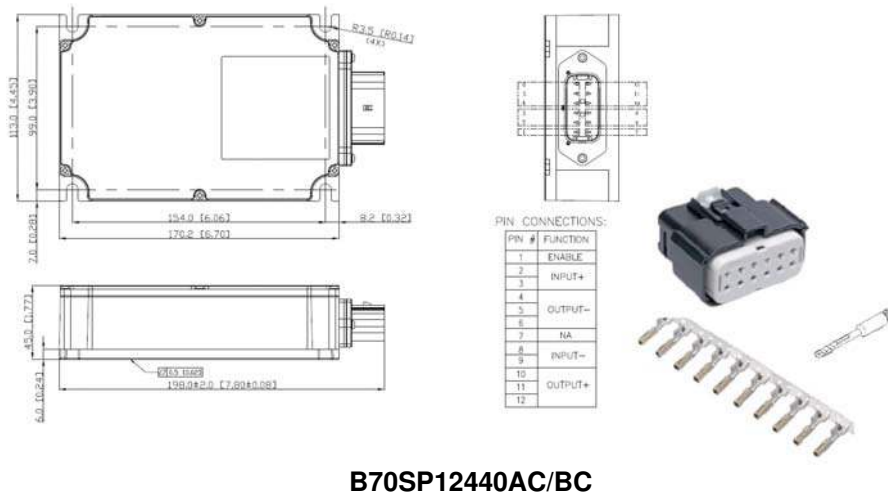

- All dimensions in mm (inches)
- Tolerance: X.X±0.5 (X.XX±0.02)
X.XX±0.25 (X.XXX±0.010)
- Connector:
MOLEX P/N : 19429-0047
(mating connector:
housing :molex 0194180027 X1
terminal: 0194200001 X11
plug :194170119 X1
Pin7 need fill with plug)

PHYSICAL OUTLINE

Case Size : 198.0x113.0x45.0mm (7.80"x4.45"x1.77")
Case Material : ADC12



PART NUMBERING SYSTEM								
B	70	S	P	124	40	A		C
Form Factor	Input Voltage	Number of Outputs	Product Series	Output Voltage	Output Current	Option Code		Option Fitting
B - Box	70 - 32V~96V	S - Single	P - High Power	124 - 12.4V	40 - 40A			Connector Kit
						A	Without parallel function	With mating connector
						B	With parallel function	With mating connector

RECOMMENDED PART NUMBER				
Input Voltage Range	Input	Output		EFF @72VIN 100% LOAD
B70SP12440(A/AC)	32V~96V	12.4V	40A	88%
B70SP12440(B/BC)	32V~96V	11.65V	42.5A	88%

CONTACT: www.deltaww.com/dcdc

Email: dcdc@deltaww.com

USA:

Telephone:
East Coast: 978-656-3993
West Coast: 510-668-5100
Fax: (978) 656 3964

Europe:

Phone: +31-20-655-0967
Fax: +31-20-655-0999

Asia & the rest of world:

Telephone: +886 3 4526107
ext 6220~6224
Fax: +886 3 4513485

WARRANTY

Delta offers a two (2) years limited warranty. Complete warranty information is listed on our web site or is available upon request from Delta.

Information furnished by Delta is believed to be accurate and reliable. However, no responsibility is assumed by Delta for its use, nor for any infringements of patents or other rights of third parties, which may result from its use. No license is granted by implication or otherwise under any patent or patent rights of Delta. Delta reserves the right to revise these specifications at any time, without notice.