

MATERIALS AND FINISHES

BODY: BRASS
PLATED TRI-M

CONTACT: BRASS
PLATED SILVER

INSULATOR: TEFLON

COUPLING NUT: BRASS
PLATED NICKEL

O-RING: SILICONE RUBBER

PERFORMANCE REQUIREMENTS:

FREQUENCY RANGE: 0-6GHz
IMPEDANCE: 50 OHMS
WITHSTAND VOLTAGE(AC): 1500V @0.5mA
RETURN LOSS: ≤-26dB(0-6GHz)
PIM3(2x20W): ≤-160dBc@1800MHz

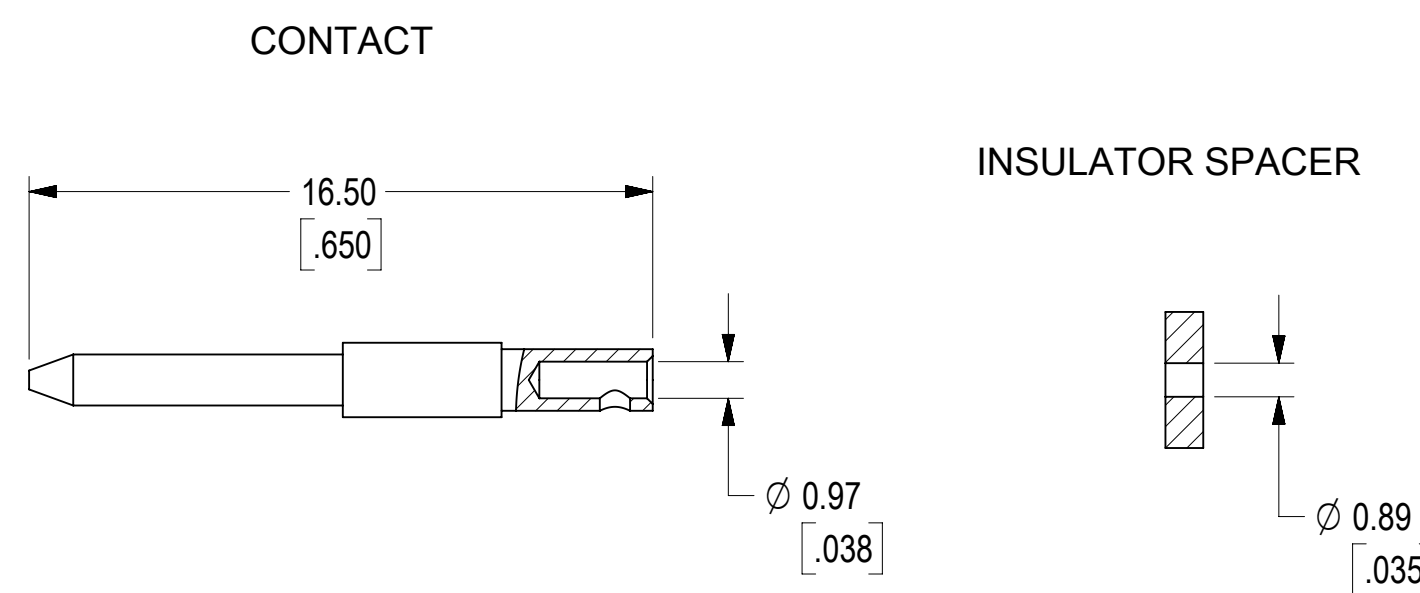
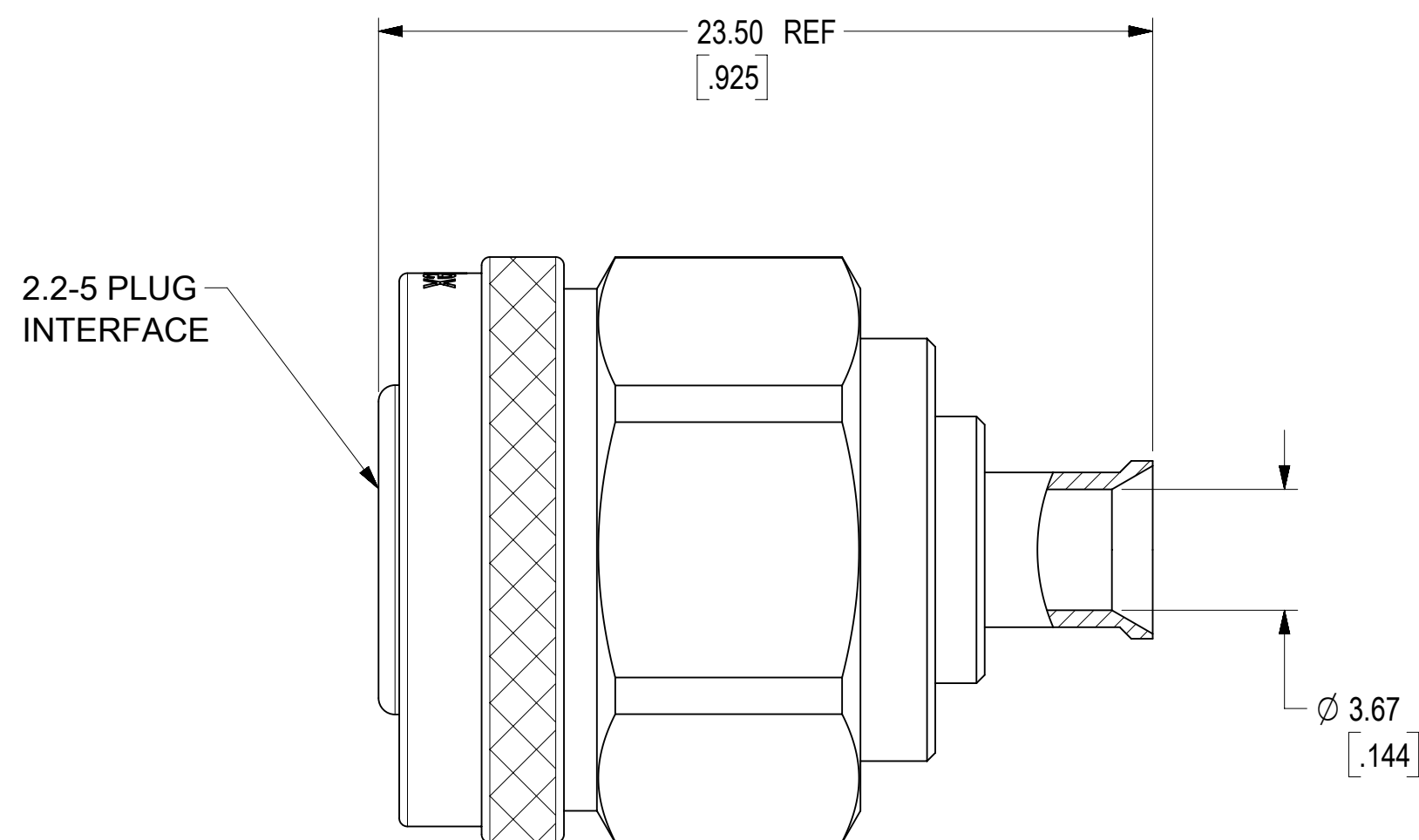
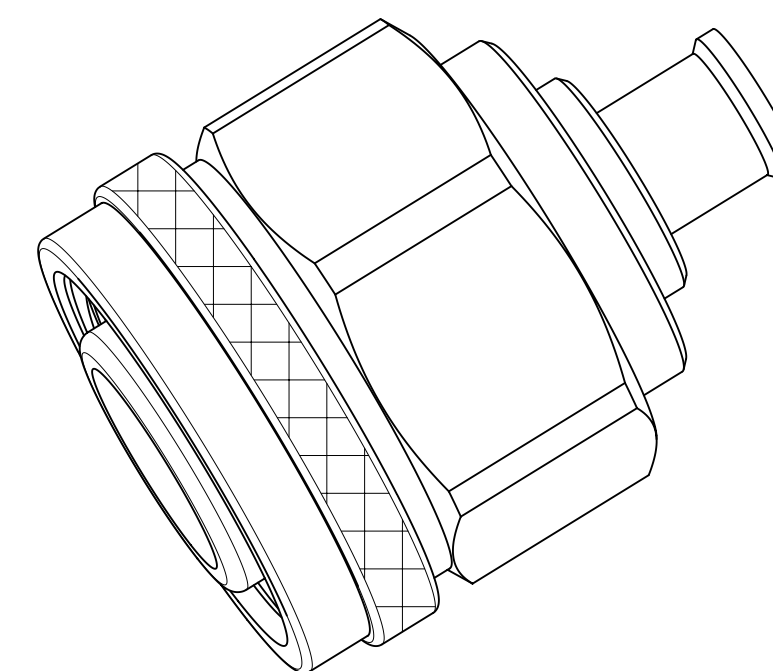

TABLE 1:

SPECIFICATION	DESCRIPTION
-----	2.2-5 INTERFACE

TABLE 2:

73225-0082	YES	CUSTOMER BOX
73225-0081	NO	BY TRAY
73225-0080	NO	BLANK
PART NO.	DUST CAP	PACKAGING

<p>SYMBOLS</p> <p>▽ = 0</p> <p>▽ = 0</p> <p>▽ = 0</p> <p>▽ = 0</p> <p>▽ = 0</p> <p>▽ = 0</p> <p>▽ = 0</p> <p>▽ = 0</p> <p>▽ = 0</p> <p>▽ = 0</p>				<p>THIS DRAWING CONTAINS INFORMATION THAT IS PROPRIETARY TO MOLEX ELECTRONIC TECHNOLOGIES, LLC AND SHOULD NOT BE USED WITHOUT WRITTEN PERMISSION</p> <p>DIMENSION UNITS: MM/INCH SCALE: 5:1</p> <p>GENERAL TOLERANCES (UNLESS SPECIFIED)</p> <p>ANGULAR TOL ± 2.0°</p> <p>4 PLACES ±</p> <p>3 PLACES ±</p> <p>2 PLACES ±</p> <p>1 PLACE ±</p> <p>0 PLACES ±</p> <p>DRAFT WHERE APPLICABLE MUST REMAIN WITHIN DIMENSIONS</p>				<p>CURRENT REV DESC:</p> <p>EC NO: 627653</p> <p>DRWN: YHUANG11 2019/06/06</p> <p>CHK'D: MXU11 2019/11/21</p> <p>APPR: LCHEN03 2019/11/22</p> <p>INITIAL REVISION:</p> <p>DRWN: YHUANG11 2019/06/06</p> <p>APPR: LCHEN03 2019/11/22</p> <p>THIRD ANGLE PROJECTION</p> <p>DRAWING SERIES: C-SIZE 73225</p>				<p>molex</p> <p>2.2-5 PLUG STR FOR 141 CABLE, 50 OHMS SOLDERING, 2.2-5-PS, EWR#: 12835-A</p> <p>PRODUCT CUSTOMER DRAWING</p> <p>DOCUMENT NUMBER: 732250080 DOC TYPE: PSD DOC PART: 000 REVISION: A</p> <p>MATERIAL NUMBER: SEE TABLE 2 CUSTOMER: GENERAL MARKET SHEET NUMBER: 1 OF 2</p>			
DOCUMENT STATUS	P1	RELEASE DATE	2019/11/22	01:39:32											

STEP 2

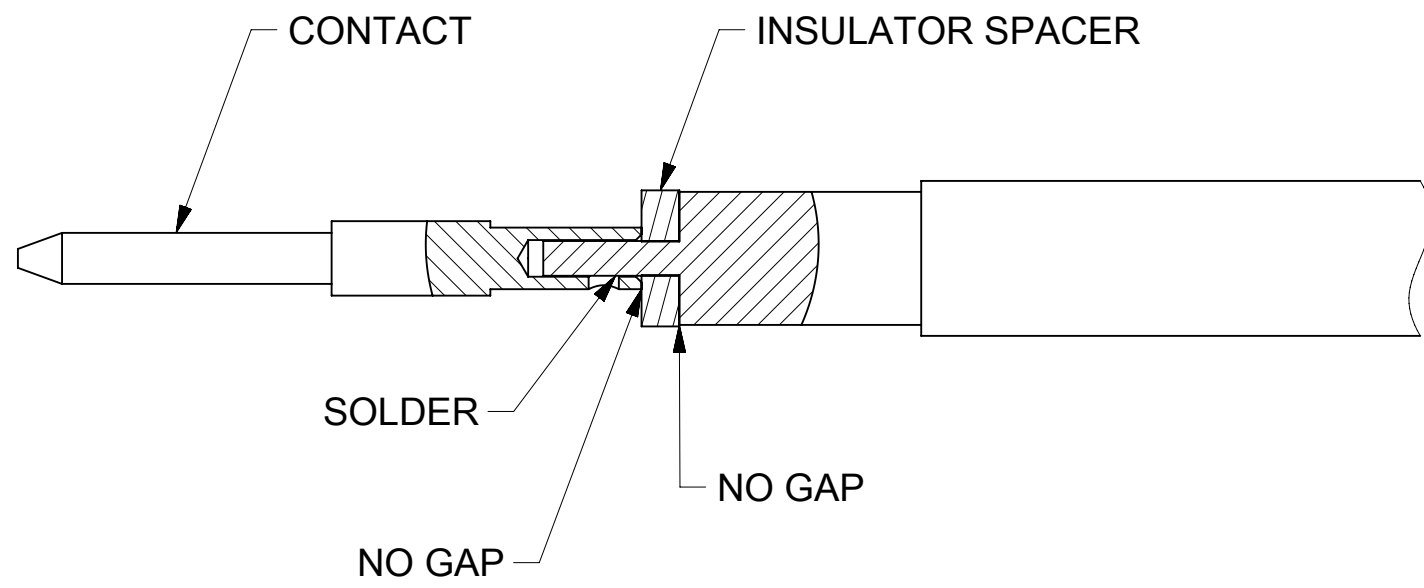

STEP 1

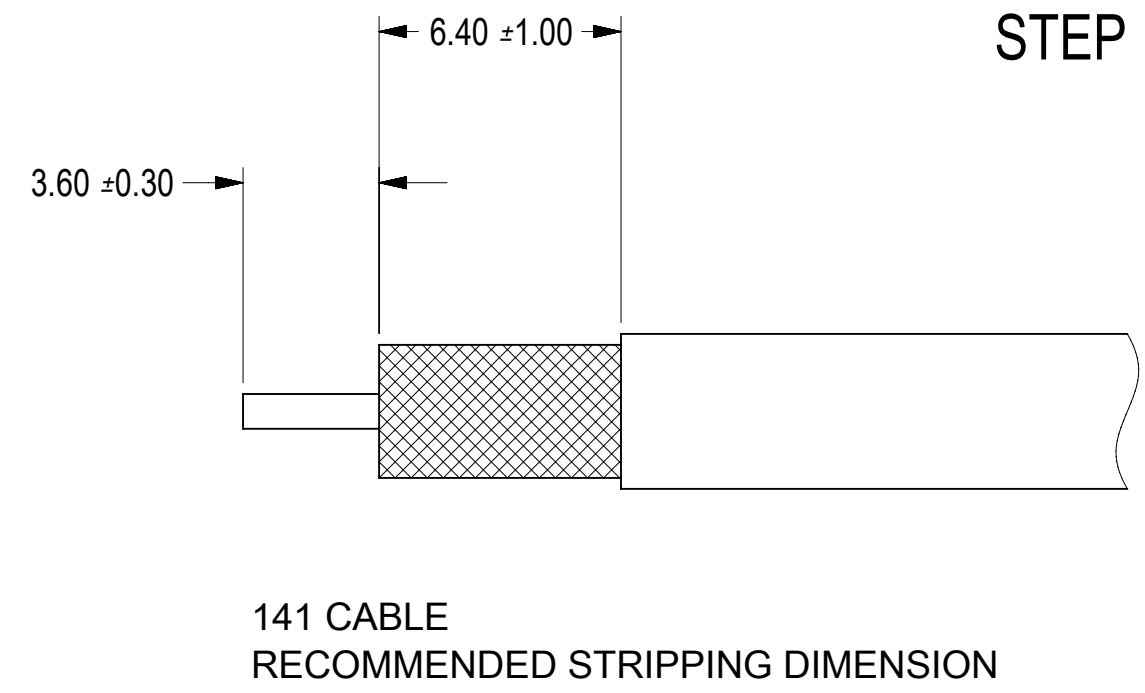

STEP 3

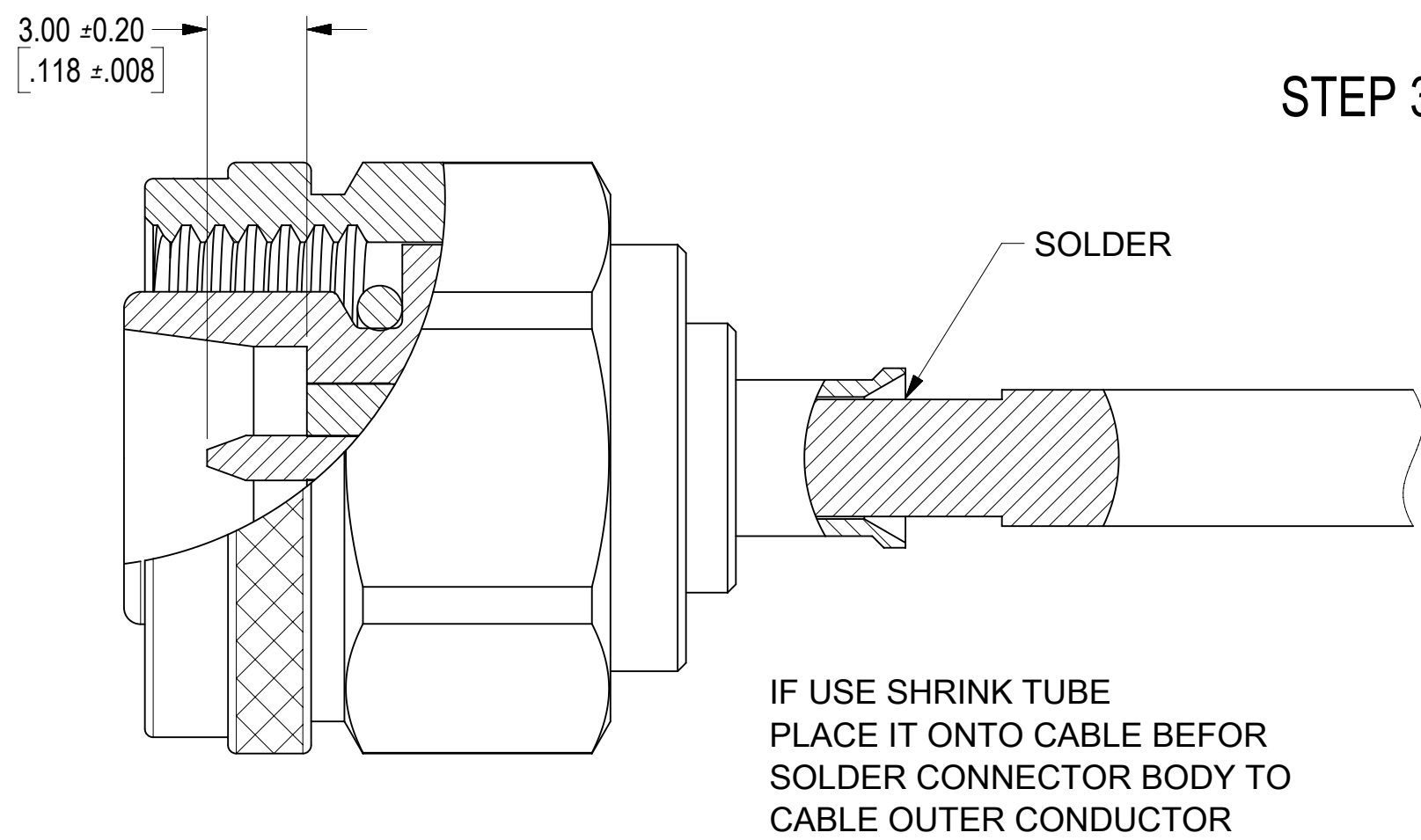

SYMBOLS ▽ = 0 ▽ = 0 ▽ = 0 ▽ = 0 ▽ = 0 ▽ = 0 ▽ = 0 ▽ = 0 ▽ = 0 ▽ = 0	THIS DRAWING CONTAINS INFORMATION THAT IS PROPRIETARY TO MOLEX ELECTRONIC TECHNOLOGIES, LLC AND SHOULD NOT BE USED WITHOUT WRITTEN PERMISSION		CURRENT REV DESC:			
	DIMENSION UNITS	SCALE				2.2-5 PLUG STR FOR 141 CABLE, 50 OHMS SOLDERING, 2.2-5-PS, EWR#: 12835-A
	MM/INCH	5:1				
	GENERAL TOLERANCES (UNLESS SPECIFIED)		EC NO: 627653		PRODUCT CUSTOMER DRAWING	
	ANGULAR TOL ± 2.0°		DRWN: YHUANG11	2019/06/06		
	4 PLACES ±		CHK'D: MXU11	2019/11/21	DOCUMENT NUMBER 732250080	
	3 PLACES ±		APPR: LCHEN03	2019/11/22		
	2 PLACES ±		INITIAL REVISION:		DOC TYPE PSD	
	1 PLACE ±		DRWN: YHUANG11	2019/06/06		
	0 PLACES ±		APPR: LCHEN03	2019/11/22	DOC PART 000	
DRAFT WHERE APPLICABLE MUST REMAIN WITHIN DIMENSIONS		THIRD ANGLE PROJECTION	DRAWING	REVISION A		
			C-SIZE		SHEET NUMBER 2 OF 2	
			SERIES			
			73225			
			MATERIAL NUMBER			
			SEE TABLE 2			
			CUSTOMER			
			GENERAL MARKET			