

THESE DRAWINGS ARE THE PROPERTY OF QUALTEK ELECTRONICS AND NOT TO BE REPRODUCED FOR OR COMMUNICATED TO A THIRD PARTY WITHOUT THE EXPRESS WRITTEN PERMISSION OF AN OFFICER OF QUALTEK ELECTRONICS.

REVISION			
REV.	DESCRIPTION	DATE	APPROVED
B	Updated Specifications	03-22-11	LY
C	Updated Graphics and Cord Specifications	09-16-11	LY

915 ± 50mm

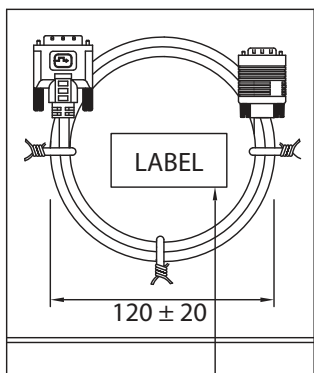
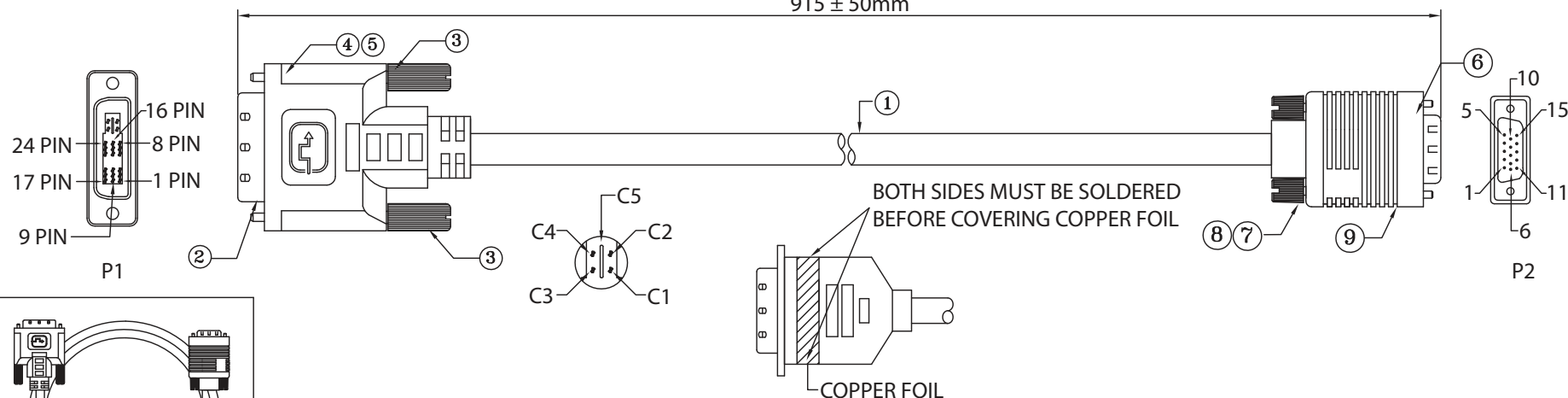

P/N:1321001-03
DVI (12+5)P/M TO HDB 15 P/M
Length:3FT
Color: Black

WIRE ARRANGEMENT		
P1	COLOR	P2
C1	RED COAXIAL	1
C2	GREEN COAXIAL	2
C3	BLUE COAXIAL	3
C4	WHITE	13
	RED COAXIAL SHIELD	6
C5	GREEN COAXIAL SHIELD	7
	BLUE COAXIAL SHIELD	8
6	GREEN	15
7	ORANGE	12
8	BROWN	14
15	BLACK	10
		5
14		
16	RED	9
CASE	BRAID SHIELD	CASE

CONTROLLED

No.	PARTS NAME	SPECIFICATION STANDARD	QTY
①	CABLE UL2919	O.D.: 7.3 ± 0.2mm BLACK COLOR	1
②	CONN 1 DVI (12+5)P/M BLACK	AU FLASH.PIN BRASS FRONT GOLD FLASH BACK TIN PLATED	1
③	SCREW	#4-40UNC MOLDED BLACK COLOR	2
④	PLASTIC HOOD	BLACK	
⑤	SHIELD CASE	TIN PLATED 0.4t ID=Ø8.0mm	
⑥	CONN 2 HDB15P/M	3R 15PIN , BLACK COLOR	1
⑦	SCREW	#4-40UNC MOLDED BLACK COLOR	2
⑧	SHIELD CASE	MUST BE SOLDERED 360°	
⑨	PLASTIC HOOD	BLACK	

NOTES:

- CABLE: UL2919
(28AWGx1PxS+AM)x3C+28AWGx4C+28AWGx1P+AB (85% AL)
OUTER JACKET: BLACK, OD: 7.3 ± 0.2mm
- CONNECTORS: DVI (12+5)P/M - HDB15P/M
- ELECTRICAL TEST:
<1>.100% OPEN SHORT & MISS WIRE TEST
<2>.INSULATION RESISTANCE: DC400V/0.01s 10M ohm MIN.
<3>.CONDUCTOR RESISTANCE: 3 ohm MAX.
- PACKING: 1PC/POLYBAG
- RoHS COMPLIANT

Qualtek Electronics Corp.
WCI DIVISION

Part Number: **1321001-03**



Description:

DVI (12+5)P/M - HDB15P/M

Dim range (mm)	Tolerance +/- (mm)	UNIT: mm		
0-1	0.15	REV.C		
1-6	0.20	UNIT: mm		
6-18	0.30	REV.C		
18-50	0.50	UNIT: mm		
50-120	0.70	REV.C		
120-250	0.90	UNIT: mm		
250-500	1.20	REV.C		

Drawn / Date

Checked / Date

Approved / Date

B.Grubb
01-24-07

01-24-07

JJH / 01-24-07