

CoreLED P/N 11003-STAR-E17 (Square)

- 5H x 5V Square
 - Nichia E17

Product Description:

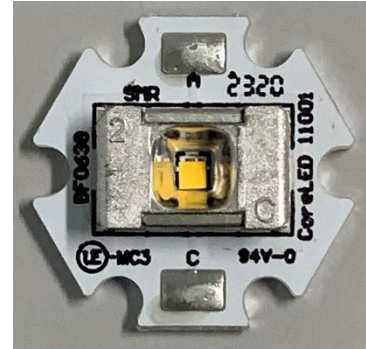

The SMR product family is a series of vacuum metallized high temperature polymer mini-reflectors that attach directly to a standard Starboard Circuit Board. These components achieve high light collection efficiency, a variety of engineered beam patterns, and are supplied for high volume electronics assembly.

Key Features:

- Optical reflector mounted on starboard for easy assembly
- Supplied on 20mm Starboard
- Increased control of light output
- Precision alignment (within ± 0.1 mm)
- Family of optical beam patterns
- Manufactured without the need for additional components to attach the optics
- Provided on starboard for evaluation and testing

Emitted Pattern Profile

Nichia E17 (Measured)

IES NEMA Type	5H x 5V
Maximum Candela	104
Maximum Candela Angle	5.0H -13.0V
Horizontal Beam Angle (50%)	55.9
Vertical Beam Angle (50%)	58.8
Horizontal Field Angle (10%)	85.6
Vertical Field Angle (10%)	89.4
Total Rated Lamp Lumens	100
Total Efficiency	79%

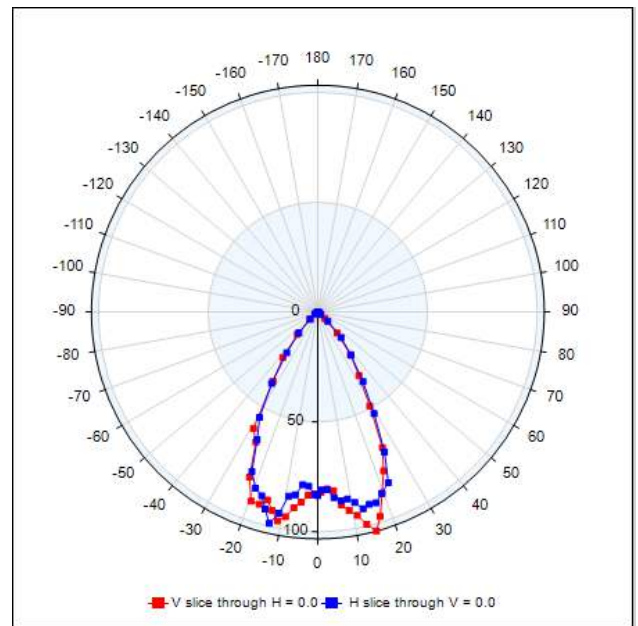
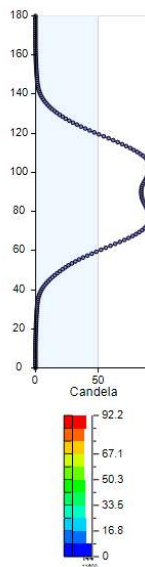
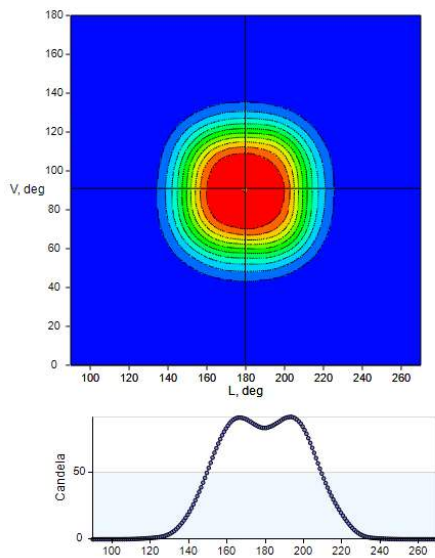

FLOOD/CANDELA VERSUS ANGLE

56 DEGREE FWHM

IES files and Raytrace models are available upon request from CoreLed Engineering.

Mechanical Profile: Reflector

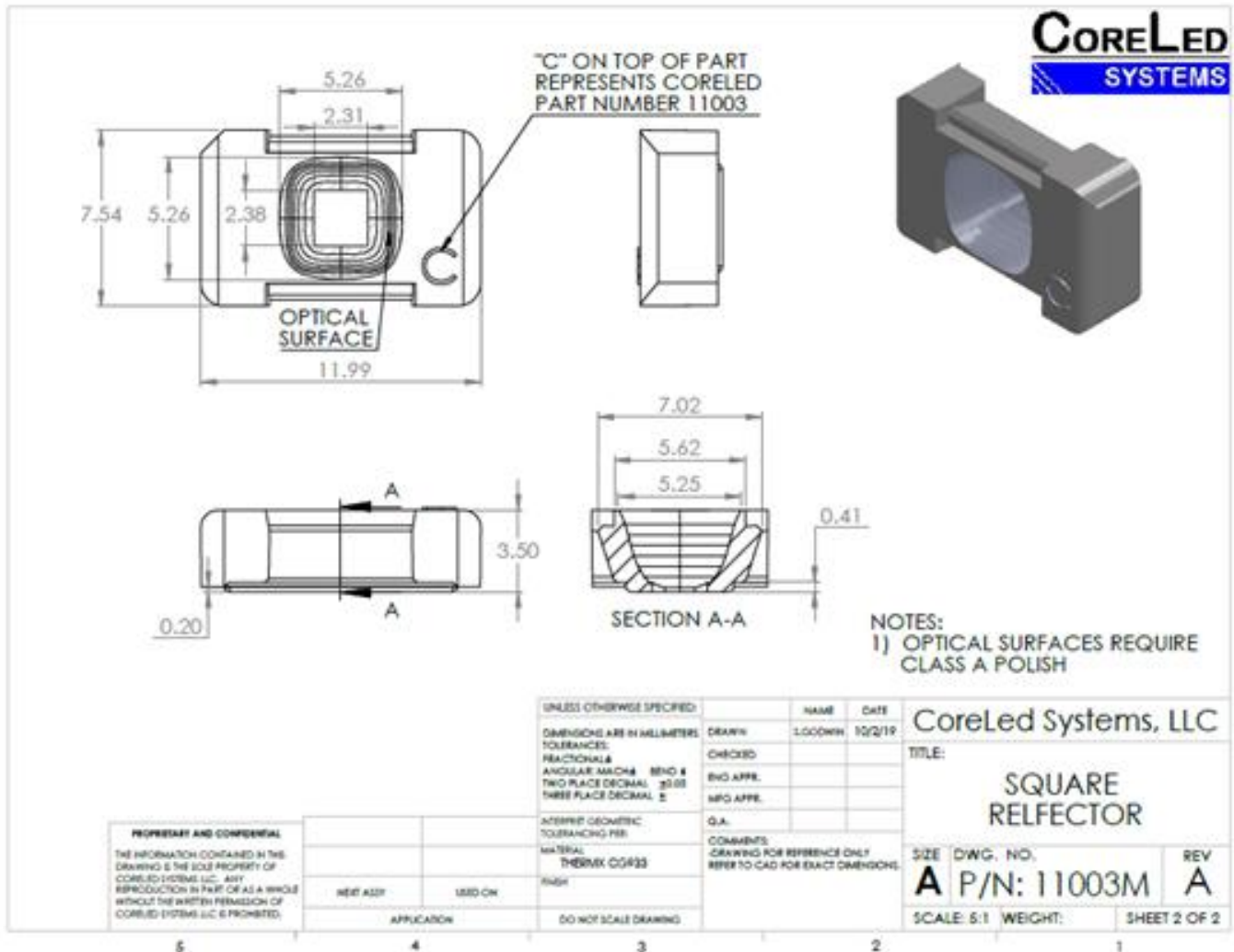

CAD files available upon request from CoreLed Engineering

LED Information



NCSWE17AT

- Pb-free Reflow Soldering Application
- RoHS Compliant

NICHIA STS-DA1-3687I <Cat.No.170112>

SPECIFICATIONS

(1) Absolute Maximum Ratings

Item	Symbol	Absolute Maximum Rating	Unit
Forward Current	I_F	700	mA
Pulse Forward Current	I_{FP}	1000	mA
Reverse Voltage	V_R	5	V
Power Dissipation	P_D	2.31	W
Operating Temperature	T_{OP}	-40~100	°C
Storage Temperature	T_{STG}	-40~100	°C
Junction Temperature	T_J	135	°C

* Absolute Maximum Ratings at $T_C=25^\circ\text{C}$.

* I_{FP} conditions with pulse width $\leq 10\text{ms}$ and duty cycle $\leq 10\%$.

(2) Initial Electrical/Optical Characteristics

Item	Symbol	Condition	Typ	Max	Unit
Forward Voltage	V_F	$I_F=350\text{mA}$	3.0	-	V
Reverse Current	I_R	$V_R=5\text{V}$	-	-	μA
R70	Luminous Flux	Φ_v $I_F=350\text{mA}$	158	-	lm
	Color Rendering Index	R_a $I_F=350\text{mA}$	72	-	-
R8000	Luminous Flux	Φ_v $I_F=350\text{mA}$	148	-	lm
	Color Rendering Index	R_a $I_F=350\text{mA}$	82	-	-
R9050	Luminous Flux	Φ_v $I_F=350\text{mA}$	125	-	lm
	Color Rendering Index	R_a $I_F=350\text{mA}$	92	-	-
R9080	Luminous Flux	Φ_v $I_F=350\text{mA}$	118	-	lm
	Color Rendering Index	R_a $I_F=350\text{mA}$	92	-	-
Chromaticity Coordinate	x	- $I_F=350\text{mA}$	0.3447	-	-
	y	- $I_F=350\text{mA}$	0.3553	-	-
Thermal Resistance	R_{thJC}	-	0.5	1.0	°C/W

* Characteristics at $T_C=25^\circ\text{C}$.

* Luminous Flux value as per CIE 127:2007 standard.

* Chromaticity Coordinates as per CIE 1931 Chromaticity Chart.

* The thermal resistance value (R_{thJC}) is used to perform logical analysis (e.g. computer-based thermal analysis simulation) and represents a thermal resistance between the die to the T_C measurement point (PCB used: Aluminum PCB $t=1.5\text{mm}$, Insulating layer $t=0.12\text{mm}$).

* For more details on thermal resistance, see CAUTIONS, (6) Thermal Management.

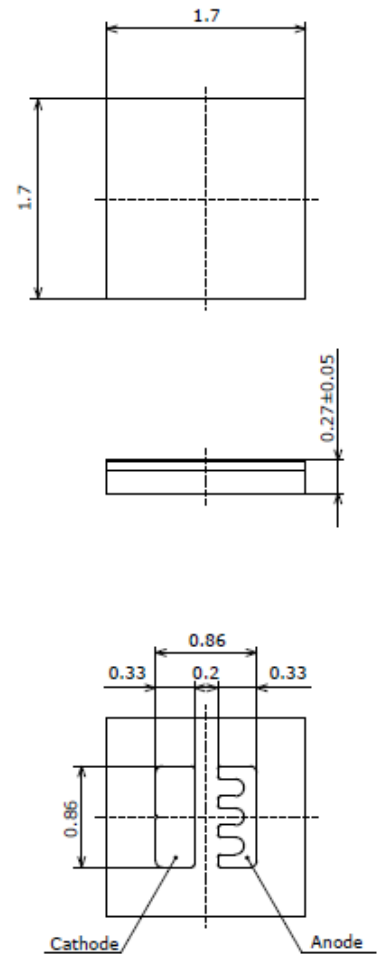

Starboard Schematic

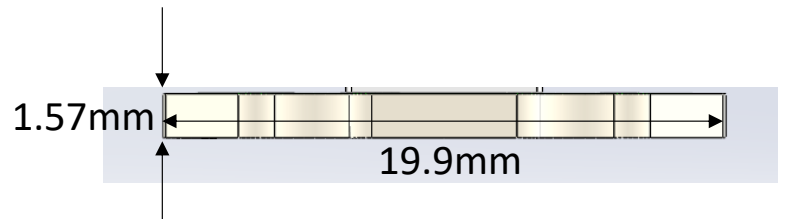
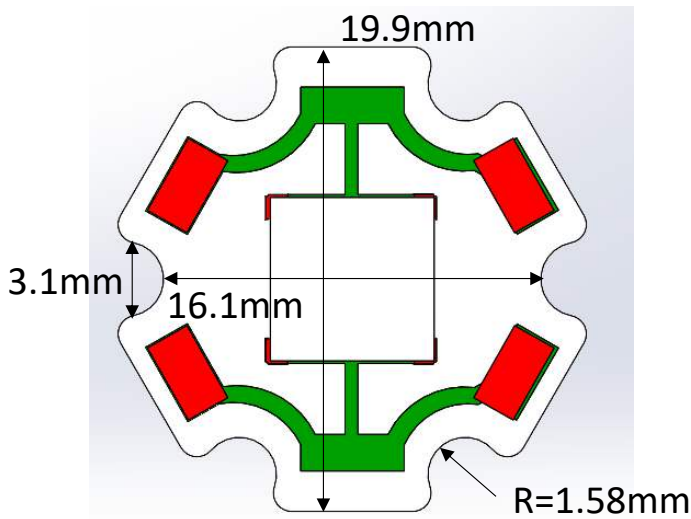
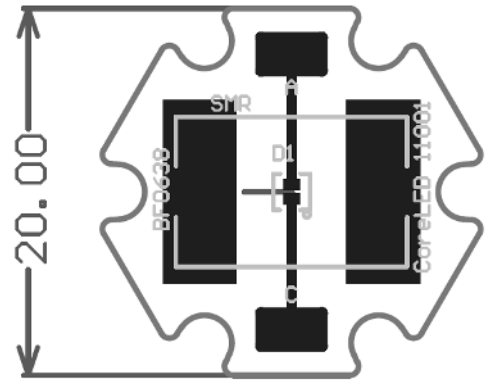
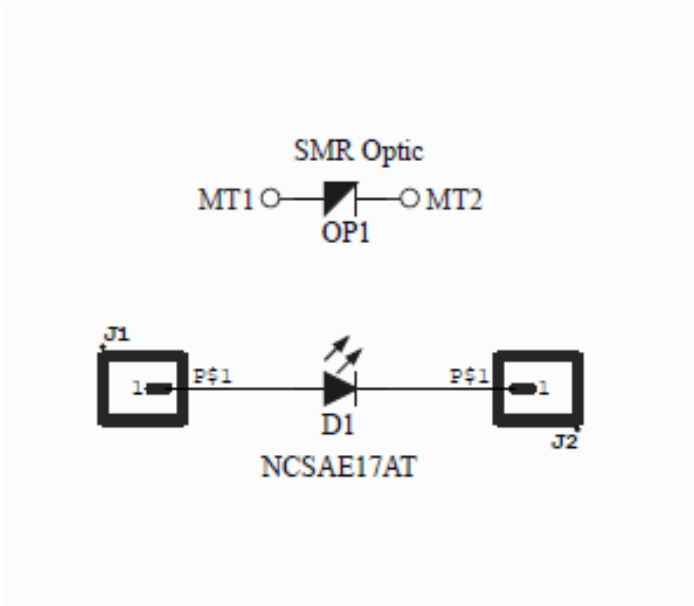



Surface Mounted Reflectors (SMR)

12mm x 7.5mm STARBOARD

Family Datasheet

Rev 1.0 – 12/31/20

Electrical:

From LED Data sheet: recommended operation is Typical 3.0V at 350mA (1 Watt to provide 150 lumens).

Thermal:

Recommended attachment to heat sink to dissipate 1W (3.0V at 350mA). LED is rated higher and can be run up to 700mA with appropriate heatsinking provided.

Packaging:

Individually packaged in static controlled bag.