



STEVAL-IFW002V1

Real-time Ethernet Xilinx FPGA extension board for the STEVAL-IFW001V1

Data Brief

Features

- Xilinx Spartan-3E FPGA device for Ethernet RT IP
- Platform Flash (XCF04S)
- CN1, CN2 connectors for plug-in connection with STEVAL-IFW001V1 demonstration board
- P1 programming connector for FPGA platform Flash (6-pin)
- P6 connector for RS485 communication through the ST3485EB transceiver
- 8 general-purpose LEDs
- 8-bit DIP switch for general configuration (e.g. device address)

Description

The STEVAL-IFW002V1 is an FPGA extension of the STEVAL-IFW001V1. This extension board was designed to handle a real-time (RT) Ethernet IP (e.g. RT HUB for Powerlink, IEEE1588, EtherCAT IP, etc.). It can also be used for evaluation of other IPs connected to the STR912FA microcontroller, such as timers, communication I/Fs. Communication between the STR912FA demonstration board and the extension can be achieved through a medium independent interface (MII), external memory interface (EMI), SPI™, GPIOs or by other methods.

RT Ethernet evaluation requires both the STEVAL-IFW001V1 demonstration board and STEVAL-IFW002V1 extension board.

Typically, the STR912FA microcontroller communicates with the on-extension real-time Ethernet logic which, in turn, communicates with the two on-board Ethernet transceivers and the microcontroller.



STEVAL-IFW002V1

1 Extension board schematic

Figure 1. Mobile connectors, LEDs and device address schematic

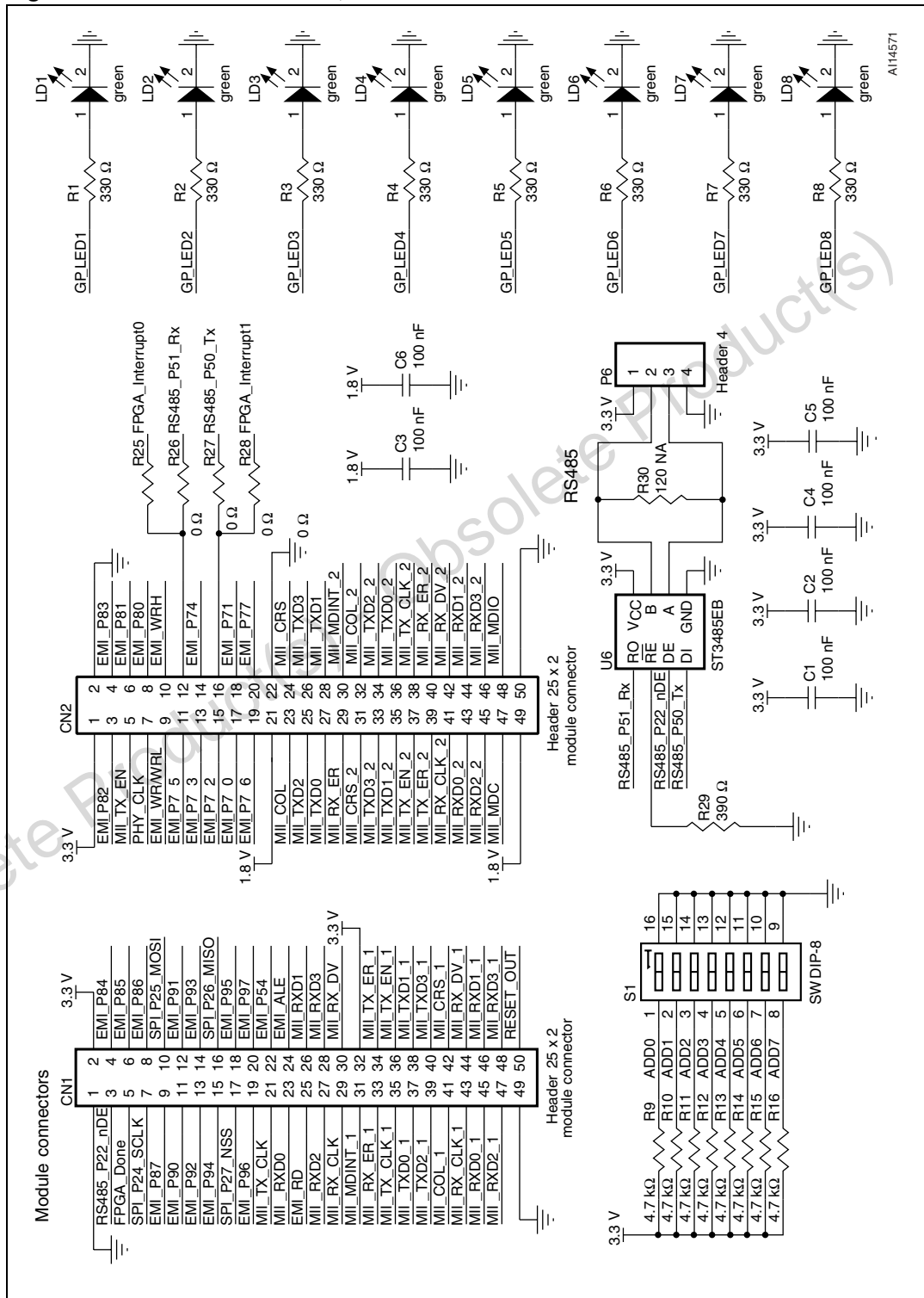

Figure 2. JTAG, Flash schematic

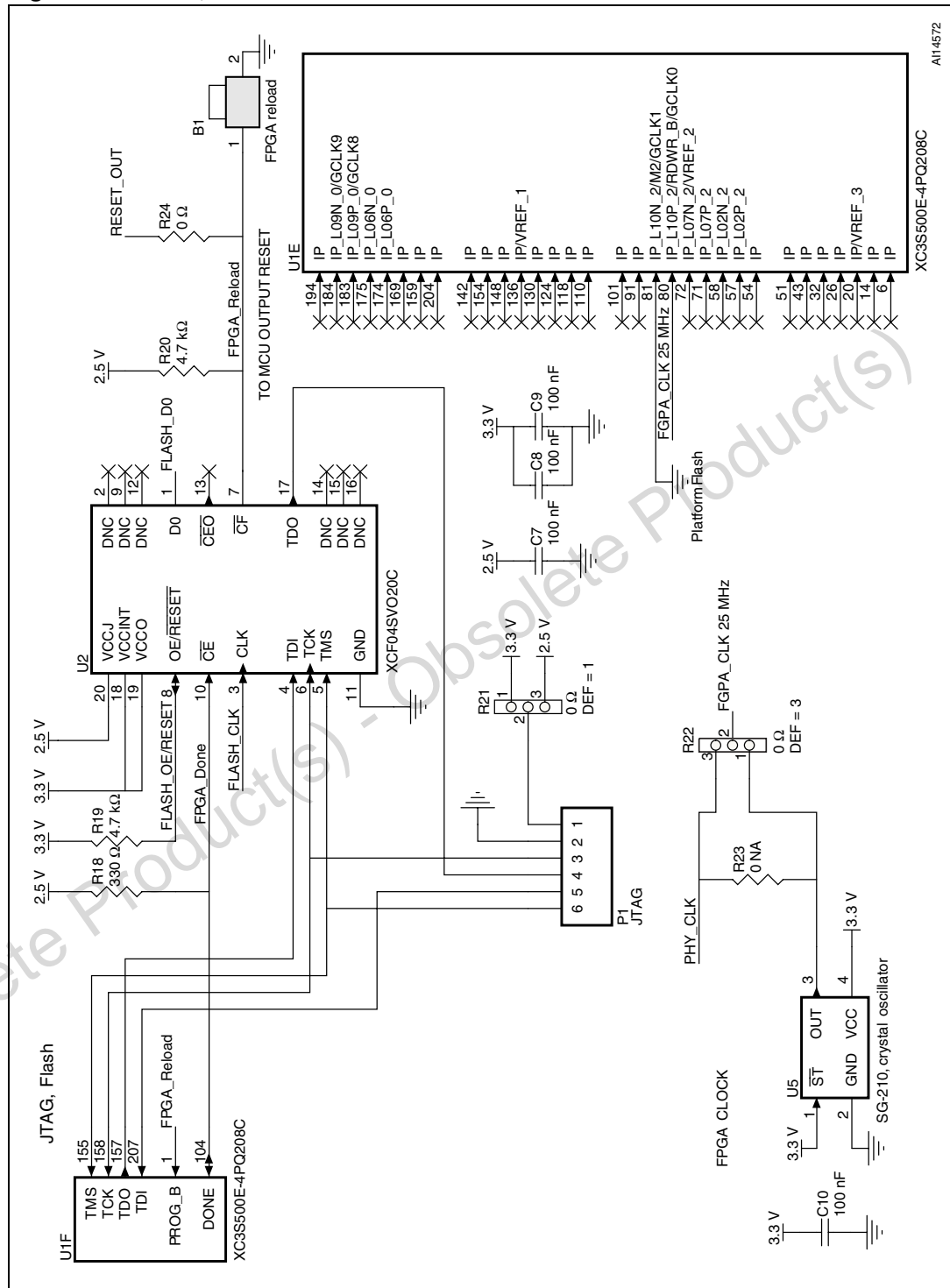
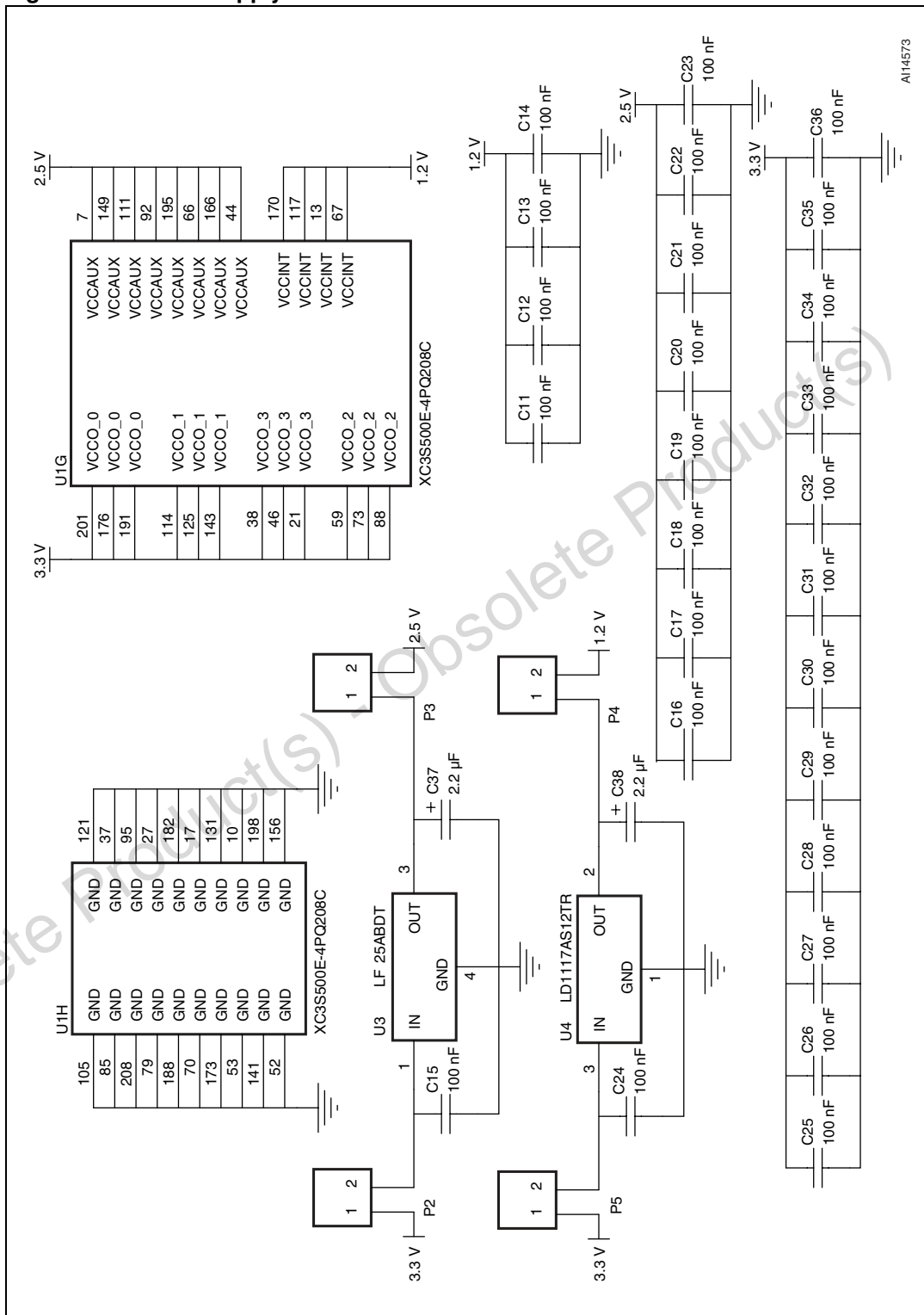
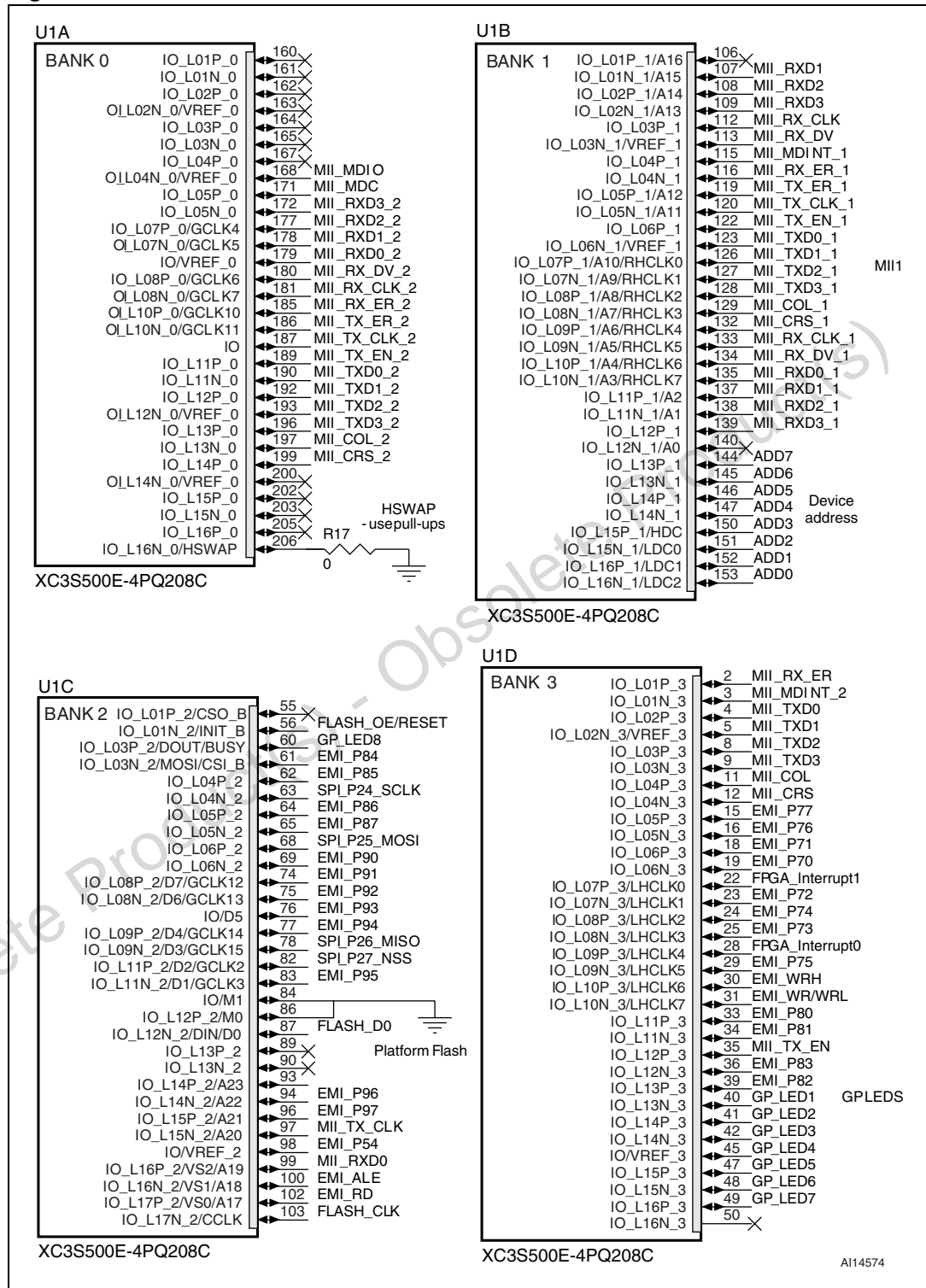

Figure 3. Power supply schematic



AI14573

Figure 4. FPGA schematic



2 Revision history

Table 1. Document revision history

Date	Revision	Changes
15-Sep-2008	1	Initial release

Obsolete Product(s) - Obsolete Product(s)

Please Read Carefully:

Information in this document is provided solely in connection with ST products. STMicroelectronics NV and its subsidiaries ("ST") reserve the right to make changes, corrections, modifications or improvements, to this document, and the products and services described herein at any time, without notice.

All ST products are sold pursuant to ST's terms and conditions of sale.

Purchasers are solely responsible for the choice, selection and use of the ST products and services described herein, and ST assumes no liability whatsoever relating to the choice, selection or use of the ST products and services described herein.

No license, express or implied, by estoppel or otherwise, to any intellectual property rights is granted under this document. If any part of this document refers to any third party products or services it shall not be deemed a license grant by ST for the use of such third party products or services, or any intellectual property contained therein or considered as a warranty covering the use in any manner whatsoever of such third party products or services or any intellectual property contained therein.

UNLESS OTHERWISE SET FORTH IN ST'S TERMS AND CONDITIONS OF SALE ST DISCLAIMS ANY EXPRESS OR IMPLIED WARRANTY WITH RESPECT TO THE USE AND/OR SALE OF ST PRODUCTS INCLUDING WITHOUT LIMITATION IMPLIED WARRANTIES OF MERCHANTABILITY, FITNESS FOR A PARTICULAR PURPOSE (AND THEIR EQUIVALENTS UNDER THE LAWS OF ANY JURISDICTION), OR INFRINGEMENT OF ANY PATENT, COPYRIGHT OR OTHER INTELLECTUAL PROPERTY RIGHT.

UNLESS EXPRESSLY APPROVED IN WRITING BY AN AUTHORIZED ST REPRESENTATIVE, ST PRODUCTS ARE NOT RECOMMENDED, AUTHORIZED OR WARRANTED FOR USE IN MILITARY, AIR CRAFT, SPACE, LIFE SAVING, OR LIFE SUSTAINING APPLICATIONS, NOR IN PRODUCTS OR SYSTEMS WHERE FAILURE OR MALFUNCTION MAY RESULT IN PERSONAL INJURY, DEATH, OR SEVERE PROPERTY OR ENVIRONMENTAL DAMAGE. ST PRODUCTS WHICH ARE NOT SPECIFIED AS "AUTOMOTIVE GRADE" MAY ONLY BE USED IN AUTOMOTIVE APPLICATIONS AT USER'S OWN RISK.

Resale of ST products with provisions different from the statements and/or technical features set forth in this document shall immediately void any warranty granted by ST for the ST product or service described herein and shall not create or extend in any manner whatsoever, any liability of ST.

ST and the ST logo are trademarks or registered trademarks of ST in various countries.

Information in this document supersedes and replaces all information previously supplied.

The ST logo is a registered trademark of STMicroelectronics. All other names are the property of their respective owners.

© 2008 STMicroelectronics - All rights reserved

STMicroelectronics group of companies

Australia - Belgium - Brazil - Canada - China - Czech Republic - Finland - France - Germany - Hong Kong - India - Israel - Italy - Japan - Malaysia - Malta - Morocco - Singapore - Spain - Sweden - Switzerland - United Kingdom - United States of America

www.st.com