

DESCRIPTION

Posifa designed the PMF5000 series of mass air flow sensors specifically for portable medical devices. The sensor is fast and accurate, enabling the precise amount of gas to be delivered in a pulse mode. The sensor's small footprint fits nicely inside a space-constrained housing. The push-to-connect fittings supports efficient assembly. The flow direction (forward or backward) can be customized to work with an existing system layout.

PMF5000 features Posifa's third-generation thermal flow die, benefiting from the latest innovations in microfabrication. The sensor die uses a pair of thermopiles to detect changes in temperature gradient caused by mass flow, delivering excellent signal-to-noise, and repeatability. The "solid state" thermal isolation structure on the sensor die eliminates the need for surface cavity or fragile membrane used in competing technologies, making the sensor resistant to clogging and pressure shock.

The PMF5000 series includes the analog output PMF5000V and the digital I²C output PMF5000D.

The PMF5000 series is a proven product that has been used in quantity in FAA approved, FDA cleared, and CE certified medical devices.

MAXIMUM RATINGS

- Operating Temperature: -25 to 85 °C
- Calibrated Temperature Range: 0 to 50 °C
- Storage Temperature: -40 to 90 °C
- Humidity: 0 to 100% RH, non-condensing
- Shock: 100 g peak (5 drops, 3 axis)
- Operating Pressure: 25 psi



FEATURES

- Unsurpassed performance in a robust and cost effective package
- "Solid state" sensing core (no surface cavity or fragile membrane) resistant to clogging and pressure shock
- Highly accurate (4% reading typ.)
- Fast response time (5 ms typ.)
- Linear output and temperature compensation
- Long-term stability with minimal null drift
- Push-to-connect fittings
- Flow direction can be changed (forward or backward) per customer request
- Analog or digital I²C output
- Proven in FAA approved, FDA cleared. and CE certified medical devices

SPECIFICATIONS

Test Conditions: $V_{in}=10\pm 0.01VDC$, $T_a=25^{\circ}C$. Relative Humidity: $40\% < RH < 60\%$

SPECIFICATIONS	MIN	TYP	MAX	UNIT	CONDITIONS
PMF5006	0		15	SLM ¹	
PMF5007	0		20	SLM	
PMF5003	0		30	SLM	
PMF5008	0		40	SLM	
PMF5009	0		60	SLM	
Output Voltage (V) ²	1 to 5			VDC	
Null Voltage (V)	0.95	1	1.05	VDC	
Output Count (D)	256 to 16124			Count	
Null Count	156		356	Count	
Null Drift		0.5		% F.S.	
Repeatability		0.2		% F.S.	
Accuracy ³		1%		F.S.	0 to 25% F.S.
		4%		Reading	25 to 100% F.S.
Resolution (D)		14		Bit	
Response Time ⁴		5		mSec	
Warm Up Time			30	mSec	
Supply Voltage (V)	6	10	16	Vdc	10V recommended
Supply Voltage (D)	4.75	10	16	Vdc	10V recommended
Supply Current		22	26	mA	at 10 VDC supply
Wetted Materials	Silicon carbide, Epoxy, Nylon (fittings), PPE+PE (main housing), FR4.				

1. SLM: standard liter per minute. Standard conditions: 0 °C and 1 atmosphere.

2. V refers to the analog version of PMF5000, and D refers to the digital I2C version.

3. Maximum deviation in output from nominal over the entire calibrated flow range and temperature range. Errors include offset, full scale span, linearity, flow hysteresis, repeatability and temperature effects over the compensated temperature range.

4. 10% to 90% rise time of the flow sensor to electrically respond to any mass flow change. May be affected by the pneumatic interface.

LINEAR OUTPUT

For **PMF5000V**

Flow Rate = $[(V_{out} - 1 V) / 4 V] \times \text{Full Scale Flow Rate}$

For example, for PMF5006V full scale flow rate is 15 SLM. When V_{out} reads 3 V, the Flow Rate is: $[(3 V - 1 V) / 4 V] \times 15 \text{ SLM} = 7.5 \text{ SLM}$

For **PMF5000D**

Flow Rate = $[(\text{Count} - 256) / 15868] \times \text{Full Scale Flow Rate}$

For example, for PMF5006V full scale rate is 15 SLM. When digital output reads 10000, the Flow Rate is:

$[(10000 - 256) / 15868] \times 15 \text{ SLM} = 9.21 \text{ SLM}$

*Contact Posifa for I²C communication app note

PACKAGE DIMENSIONS

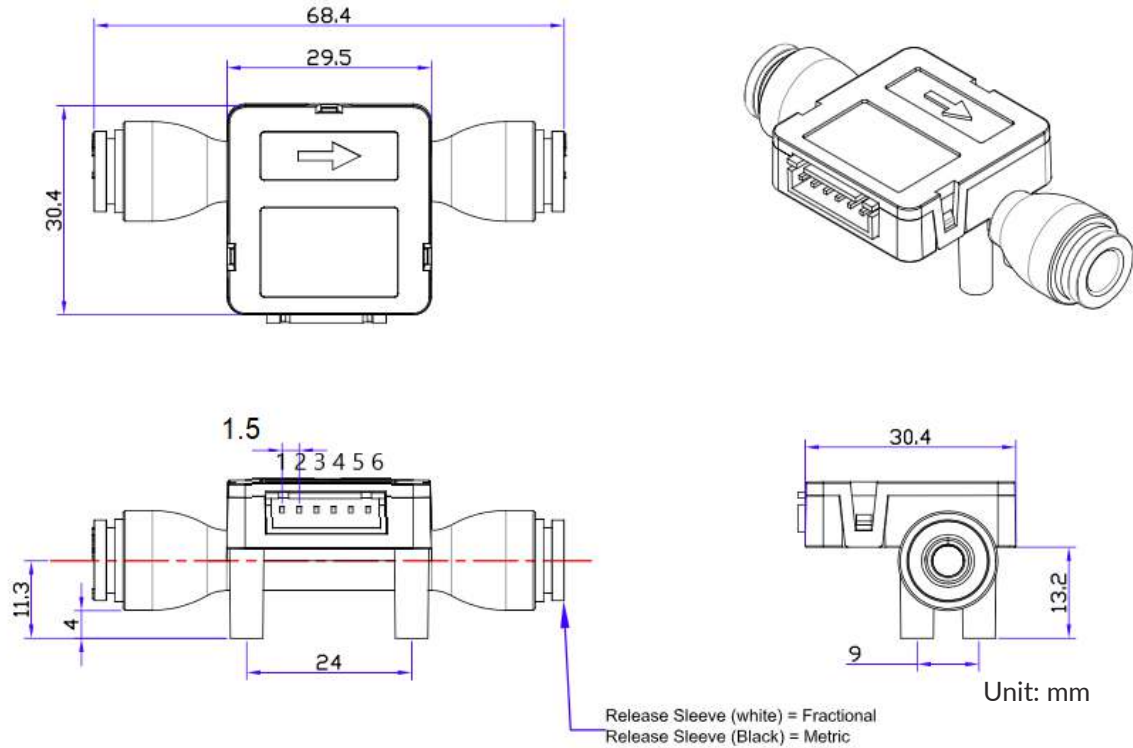

PMF5000V

Pin#	Description
1	Null
2	Null
3	GND
4	VDD
5	OUT
6	Null

PMF5000D

Pin#	Description
1	SCL
2	SDA
3	GND
4	VDD
5	Null
6	Null

Mating connector:

JST ZH Connector
Contact: S6B-ZR-SM2-TF

Contact Posifa for sensor CAD model

ORDERING INFORMATION

PART NUMBER	SPECIFICATIONS
PMF5006D	15 SLM, I ² C, Linear
PMF5007D	20 SLM, I ² C, Linear
PMF5003D	30 SLM, I ² C, Linear
PMF5008D	40 SLM, I ² C, Linear
PMF5009D	60 SLM, I ² C, Linear

Note:

Order 1 to 5V analog output models by specifying "V" instead of "D" in part numbers above.

Please use suffix -IN or -MM to indicated desired tubing dimensions. -IN is for 1/4 OD tubing, and -MM for 6mm OD tubing.

Please contact Posifa or your local distributor to place an order.

EUROPEAN DISTRIBUTOR

BS-rep GmbH

Eichertstr. 68, D-56745 Weibern, Germany

Tel: +49 (0) 2655 / 96 26 476

Email: info@sensor-rep.de

CUSTOMIZATION OPTIONS

If the standard product described in this datasheet does not completely meet your needs, please contact Posifa Technologies to discuss other options. Help us understand your application and sensor requirements and we can work together to find the best overall solution.