

PRODUCT NUMBER	PLATING		ISOLATION DIA MAX	AWG	MATERIAL BODY
	BODY	SPRING			
75222-002LF	1µm GOLD	GOLD FLASH	1.8	22-26	BRASS

"LF" SEE NOTES

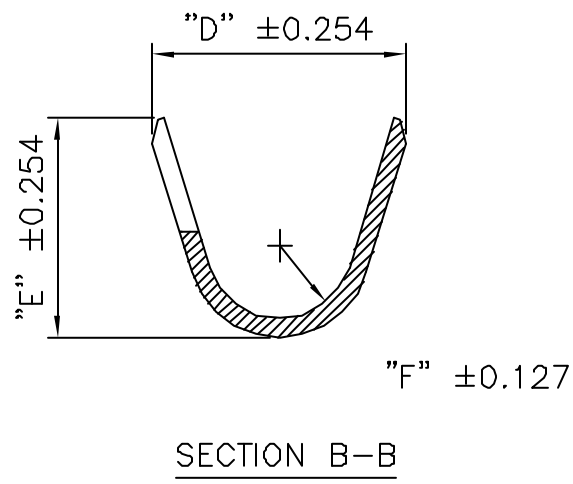
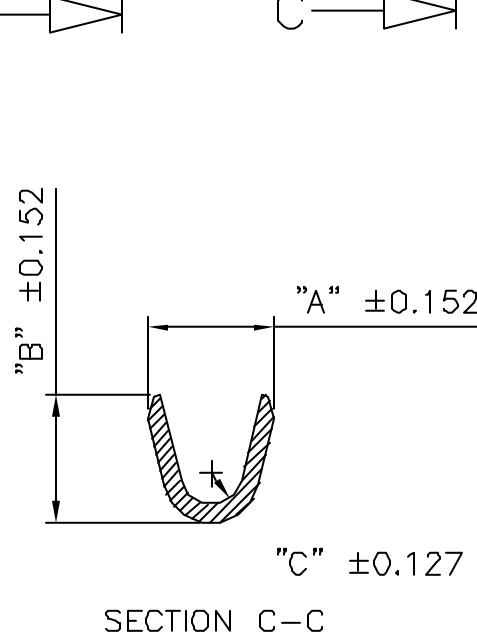
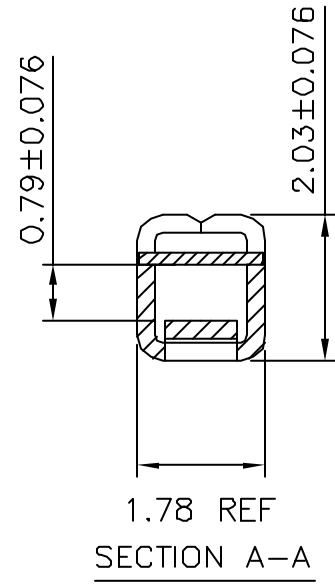
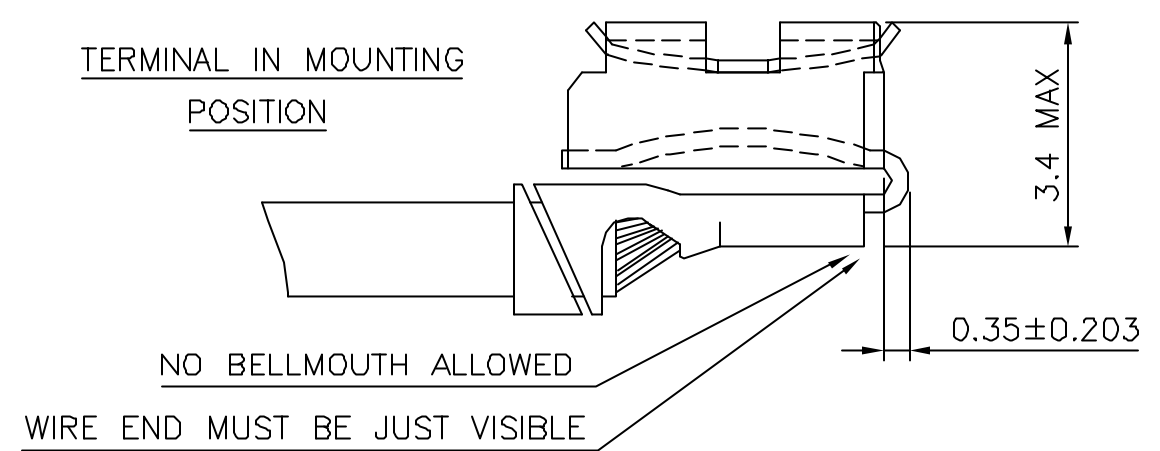
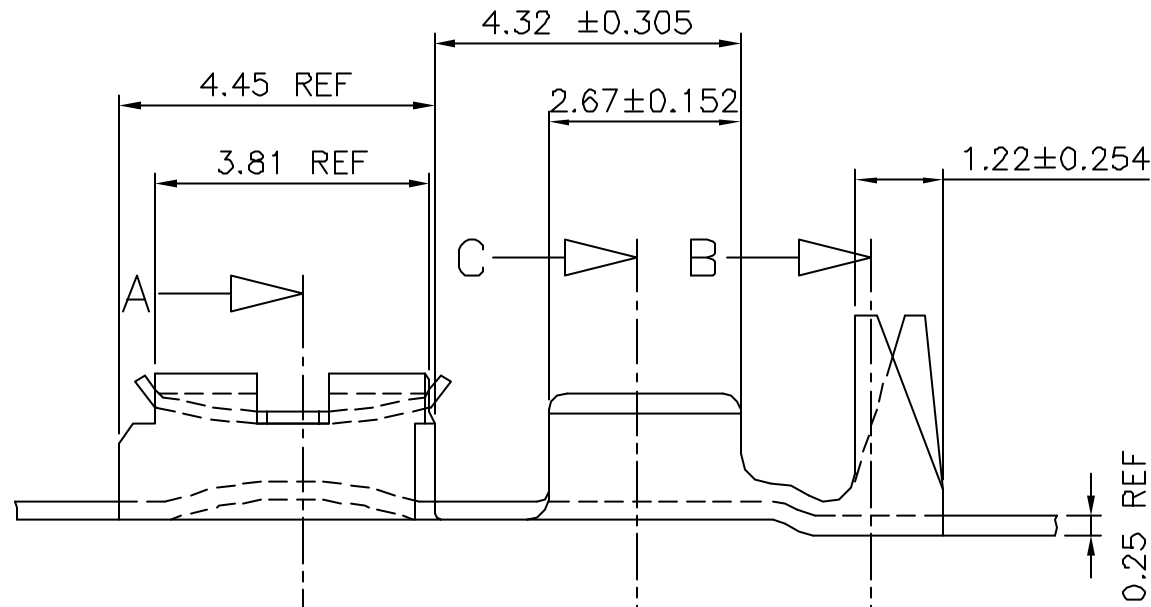

NOTES:

- MATERIAL BODY, SEE TABLE
- MATERIAL SPRING : Be Cu.
- LOOSE PIECE TERMINAL, SEE DRAWING 75228.
- RECOMMENDED WIRE STRIP LENGTH, 3.81±0.25
- 75222-XXXLF IS SIMILAR TO 75222-XXX, THE SUFFIX 'LF' IS ADDED FOR LEAD FREE IDENTIFICATION.
- RoHS COMPATIBLE PRODUCT SPECIFICATIONS
- b - LABELING:
 - MEETS PACKAGING SPECS AS PER GS-14-920
- c - LEGAL STATEMENT: SEE GS-22-008
THE PRODUCT IS NOT INTENDED TO BE EXPOSED TO A MANUFACTURING SOLDER PROCESS.

AWG	"A"	"B"	"C"	"D"	"E"	"F"
22-26	1.78	1.78	0.43	3.53	3.05	1.27
28-32	1.37	1.47	0.28	2.92	2.67	1.02

mat'l. code SEE P/N				surface ISO 1302 ✓	tolerance ISO 406 ISO 101	projection mm	product family BERGCON	
ltr	ecn no	dr	date	tolerances unless otherwise specified		mm	title JUMBO PV ON STRIP	
G	F20410	OMA	92.08.03	angles	linear			
H	F50036	JMC	95.01.19			scale 10:1	dwg no 75222 sheet 1 of 1 size A3 type CUSTOMER Drawing	
J	F05-0235	DLE	05.08.25			FCJ		
K	F05-0286	DLE	05.11.07	dr	COMPAGNON J			95.01.19
L	F06-0217	DLE	06.07.11	enfr	PHAMVAN			95.01.19
				chr	COMPAGNON J	95.01.19		
				appd	JMP	95.01.19		
sheet index	revision sheet							