

PHOTONIC DETECTORS INC.

Silicon Photodiode, Blue Enhanced Photovoltaic Isolated Type PDB-V104-I

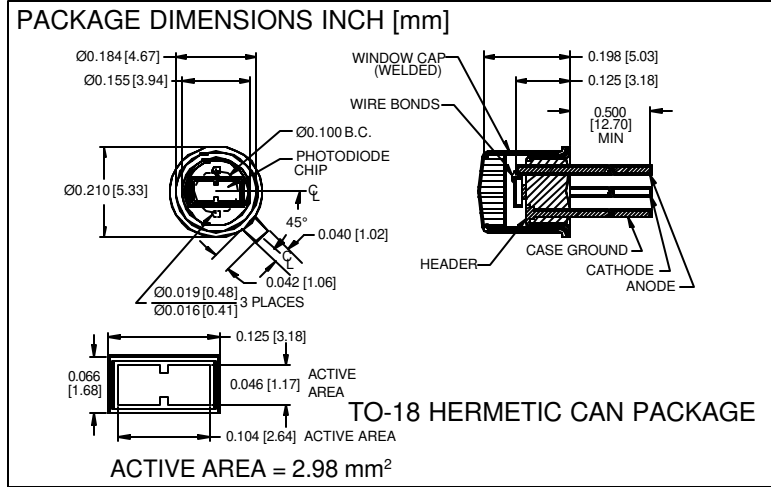

FEATURES

- Low noise
- Blue enhanced
- High shunt resistance
- High response

DESCRIPTION

The **PDB-V104-I** is a silicon, PIN planar diffused, blue enhanced photodiode. Ideal for low noise photovoltaic applications. Packaged in a hermetic TO-18 metal can with a flat window and isolated ground lead.

APPLICATIONS

- Instrumentation
- Character recognition
- Laser detection
- Industrial controls

ABSOLUTE MAXIMUM RATING (TA=25°C unless otherwise noted)

SYMBOL	PARAMETER	MIN	MAX	UNITS
V _{BR}	Reverse Voltage		75	V
T _{STG}	Storage Temperature	-55	+150	°C
T _O	Operating Temperature Range	-40	+125	°C
T _S	Soldering Temperature*		+240	°C
I _L	Light Current		0.5	mA

*1/16 inch from case for 3 secs max

SPECTRAL RESPONSE

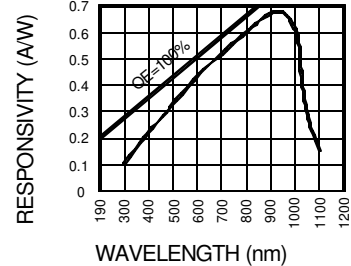

ELECTRO-OPTICAL CHARACTERISTICS (TA=25°C unless otherwise noted)

SYMBOL	CHARACTERISTIC	TEST CONDITIONS	MIN	TYP	MAX	UNITS
I _{SC}	Short Circuit Current	H = 100 fc, 2850 K	35	40		mA
I _D	Dark Current	H = 0, V _R = 10 V		150	300	pA
R _{SH}	Shunt Resistance	H = 0, V _R = 10 mV	1.0	6		GΩ
TC R _{SH}	RSH Temp. Coefficient	H = 0, V _R = 10 mV		-8		% / °C
C _J	Junction Capacitance	H = 0, V _R = 0 V**		340		pF
λ _{range}	Spectral Application Range	Spot Scan	350		1100	nm
λ _p	Spectral Response - Peak	Spot Scan		950		nm
V _{BR}	Breakdown Voltage	I = 10 mA	30	50		V
NEP	Noise Equivalent Power	V _R = 10 mV @ Peak		5x10 ⁻¹⁴		W/√Hz
tr	Response Time	RL = 1 KΩ V _R = 0 V		450		nS

Information in this technical data sheet is believed to be correct and reliable. However, no responsibility is assumed for possible inaccuracies or omission. Specifications are subject to change without notice. **f = 1 MHz