

4-Mbit (256K x 16) Static RAM

Features

- Pin equivalent to CY7C1041BV33
- Temperature Ranges
 - Commercial: 0°C to 70°C
 - Industrial: -40°C to 85°C
 - Automotive-A: -40°C to 85°C
 - Automotive-E: -40°C to 125°C
- High speed
 - $t_{AA} = 10$ ns
- Low active power
 - 324 mW (max.)
- 2.0V data retention
- Automatic power-down when deselected
- TTL-compatible inputs and outputs
- Easy memory expansion with \overline{CE} and \overline{OE} features
- Available in Pb-free and non Pb-free 44-pin 400-mil-SOJ, 44-pin TSOP II and 48-ball FBGA packages

Functional Description^[1]

The CY7C1041CV33 is a high-performance CMOS Static RAM organized as 262,144 words by 16 bits.

Writing to the device is accomplished by taking Chip Enable (\overline{CE}) and Write Enable (\overline{WE}) inputs LOW. If Byte LOW Enable (\overline{BLE}) is LOW, then data from I/O pins (I/O_0 – I/O_7), is written into the location specified on the address pins (A_0 – A_{17}). If Byte HIGH Enable (\overline{BHE}) is LOW, then data from I/O pins (I/O_8 – I/O_{15}) is written into the location specified on the address pins (A_0 – A_{17}).

Reading from the device is accomplished by taking Chip Enable (\overline{CE}) and Output Enable (\overline{OE}) LOW while forcing the Write Enable (\overline{WE}) HIGH. If Byte LOW Enable (\overline{BLE}) is LOW, then data from the memory location specified by the address pins will appear on I/O_0 – I/O_7 . If Byte HIGH Enable (\overline{BHE}) is LOW, then data from memory will appear on I/O_8 to I/O_{15} . See the truth table at the back of this data sheet for a complete description of Read and Write modes.

The input/output pins (I/O_0 – I/O_{15}) are placed in a high-impedance state when the device is deselected (\overline{CE} HIGH), the outputs are disabled (\overline{OE} HIGH), the \overline{BHE} and \overline{BLE} are disabled (\overline{BHE} , \overline{BLE} HIGH), or during a Write operation (\overline{CE} LOW, and \overline{WE} LOW).

The CY7C1041CV33 is available in a standard 44-pin 400-mil-wide body width SOJ and 44-pin TSOP II package with center power and ground (revolutionary) pinout, as well as a 48-ball fine-pitch ball grid array (FBGA) package.

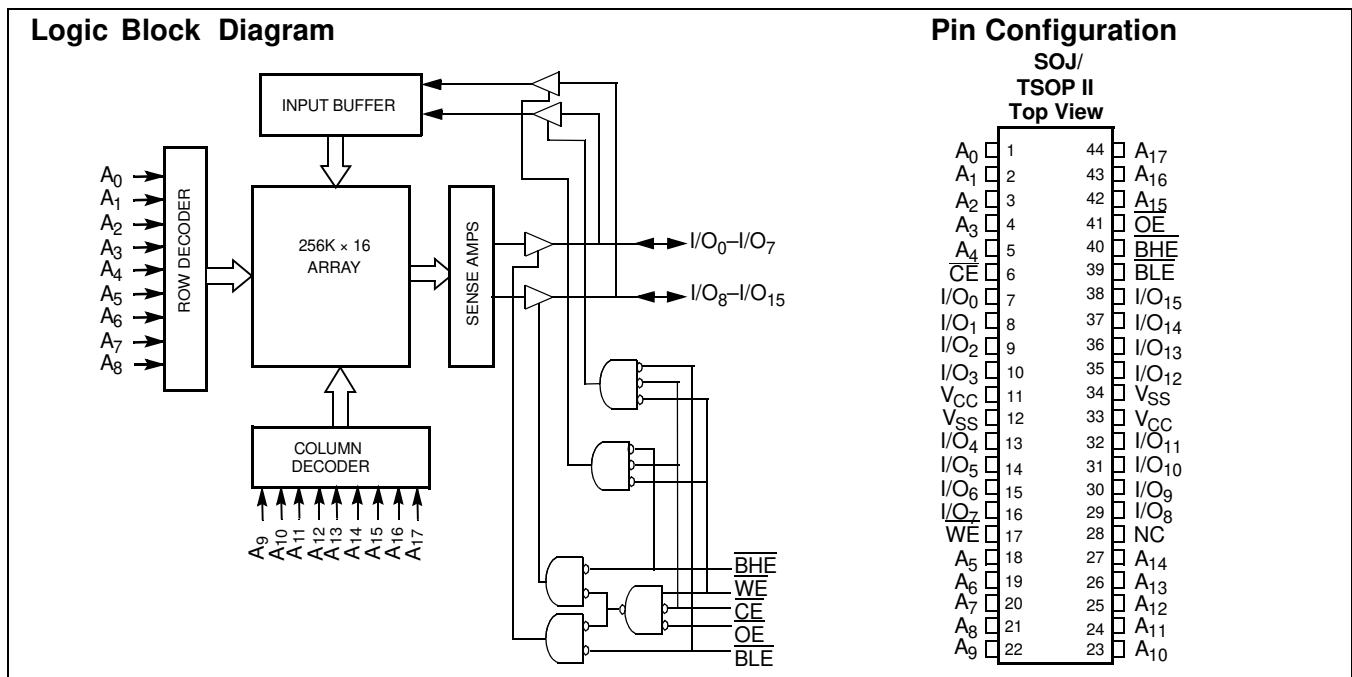

Notes:

1. For guidelines on SRAM system design, please refer to the "System Design Guidelines" Cypress application note, available on the internet at www.cypress.com.

Selection Guide

		-10	-12	-15	-20	Unit
Maximum Access Time		10	12	15	20	ns
Maximum Operating Current	Commercial	90	85	80	75	mA
	Industrial	100	95	90	85	mA
	Automotive-A	100			85	mA
	Automotive-E				90	mA
Maximum CMOS Standby Current	Commercial/ Industrial	10	10	10	10	mA
	Automotive-A	10				mA
	Automotive-E				15	mA

Pin Configurations

**48-ball FBGA
(Top View)**

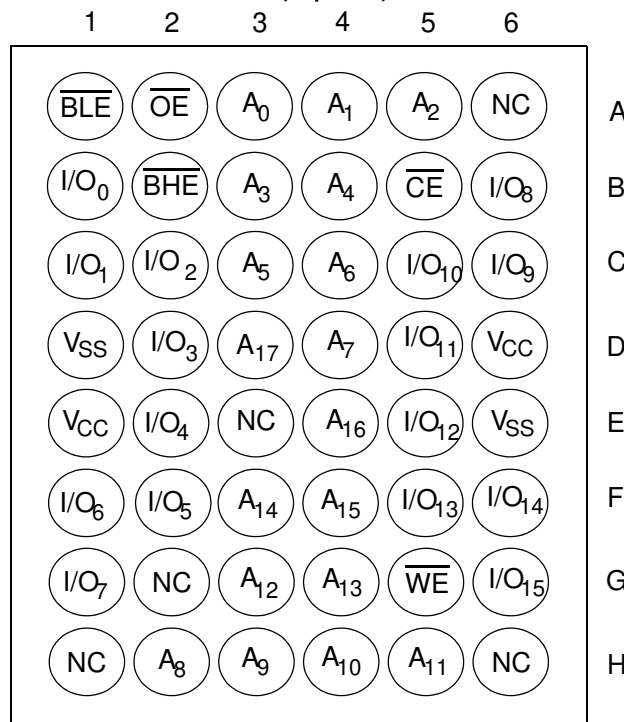

Pin Definitions

Pin Name	44-SOJ, 44-TSOP Pin Number	48-ball FBGA Pin Number	I/O Type	Description
A ₀ –A ₁₇	1–5, 18–27, 42–44	A3, A4, A5, B3, B4, C3, C4, D4, H2, H3, H4, H5, G3, G4, F3, F4, E4, D3	Input	Address Inputs used to select one of the address locations.
I/O ₀ –I/O ₁₅	7–10,13–16, 29–32, 35–38	B1, C1, C2, D2, E2, F2, F1, G1, B6, C6, C5, D5, E5, F5, F6, G6	Input/Output	Bidirectional Data I/O lines. Used as input or output lines depending on operation
NC	28	A6, E3, G2, H1, H6	No Connect	No Connects. This pin is not connected to the die
\overline{WE}	17	G5	Input/Control	Write Enable Input, active LOW. When selected LOW, a WRITE is conducted. When selected HIGH, a READ is conducted.
\overline{CE}	6	B5	Input/Control	Chip Enable Input, active LOW. When LOW, selects the chip. When HIGH, deselects the chip.
\overline{BHE} , \overline{BLE}	40, 39	B2, A1	Input/Control	Byte Write Select Inputs, active LOW. \overline{BHE} controls I/O ₁₅ –I/O ₈ , \overline{BLE} controls I/O ₇ –I/O ₀
\overline{OE}	41	A2	Input/Control	Output Enable, active LOW. Controls the direction of the I/O pins. When LOW, the I/O pins are allowed to behave as outputs. When deasserted HIGH, I/O pins are tri-stated, and act as input data pins.
V _{SS}	12, 34	D1, E6	Ground	Ground for the device. Should be connected to ground of the system.
V _{CC}	11, 33	D6, E1	Power Supply	Power Supply inputs to the device.

Maximum Ratings

(Above which the useful life may be impaired. For user guidelines, not tested.)

Storage Temperature	-65°C to +150°C
Ambient Temperature with Power Applied	-55°C to +125°C
Supply Voltage on V _{CC} to Relative GND ^[2]	-0.5V to +4.6V
DC Voltage Applied to Outputs in High-Z State ^[2]	-0.5V to V _{CC} + 0.5V
DC Input Voltage ^[2]	-0.5V to V _{CC} + 0.5V
Current into Outputs (LOW)	20 mA

Static Discharge Voltage.....>2001V
(per MIL-STD-883, Method 3015)

Latch-up Current..... >200 mA

Operating Range

Range	Ambient Temperature	V _{CC}
Commercial	0°C to +70°C	3.3V ± 0.3V
Industrial	-40°C to +85°C	
Automotive-A	-40°C to +85°C	
Automotive-E	-40°C to +125°C	

DC Electrical Characteristics Over the Operating Range

Parameter	Description	Test Conditions	-10		-12		-15		-20		Unit		
			Min.	Max.	Min.	Max.	Min.	Max.	Min.	Max.			
V _{OH}	Output HIGH Voltage	V _{CC} = Min., I _{OH} = -4.0 mA	2.4		2.4		2.4		2.4		V		
V _{OL}	Output LOW Voltage	V _{CC} = Min., I _{OL} = 8.0 mA		0.4		0.4		0.4		0.4	V		
V _{IH}	Input HIGH Voltage		2.0	V _{CC} + 0.3	2.0	V _{CC} + 0.3	2.0	V _{CC} + 0.3	2.0	V _{CC} + 0.3	V		
V _{IL} ^[2]	Input LOW Voltage		-0.3	0.8	-0.3	0.8	-0.3	0.8	-0.3	0.8	V		
I _{IX}	Input Leakage Current	GND ≤ V _I ≤ V _{CC}	Com'I/Ind'I	-1	+1	-1	+1	-1	+1	-1	+1	μA	
			Auto-A	-1	+1					-1	+1	μA	
			Auto-E							-20	+20	μA	
I _{OZ}	Output Leakage Current	GND ≤ V _{OUT} ≤ V _{CC} , Output Disabled	Com'I/Ind'I	-1	+1	-1	+1	-1	+1	-1	+1	μA	
			Auto-A	-1	+1					-1	+1	μA	
			Auto-E							-20	+20	μA	
I _{CC}	V _{CC} Operating Supply Current	V _{CC} = Max., f = f _{MAX} = 1/t _{RC}	Com'I		90		85		80		75	mA	
			Ind'I		100		95		90		85	mA	
			Auto-A		100							85	mA
			Auto-E									90	mA
I _{SB1}	Automatic CE Power-down Current —TTL Inputs	Max. V _{CC} , CE ≥ V _{IH} , V _{IN} ≥ V _{IH} or V _{IN} ≤ V _{IL} , f = f _{MAX}	Com'I/Ind'I		40		40		40		40	mA	
			Auto-A		40						40	mA	
			Auto-E									45	mA
I _{SB2}	Automatic CE Power-down Current —CMOS Inputs	Max. V _{CC} , CE ≥ V _{CC} - 0.3V, V _{IN} ≥ V _{CC} - 0.3V, or V _{IN} ≤ 0.3V, f = 0	Com'I/Ind'I		10		10		10		10	mA	
			Auto-A		10						10	mA	
			Auto-E									15	mA

Capacitance^[3]

Parameter	Description	Test Conditions	Max.	Unit
C _{IN}	Input Capacitance	T _A = 25°C, f = 1 MHz, V _{CC} = 3.3V	8	pF
C _{OUT}	I/O Capacitance		8	pF

Notes:

- V_{IL} (min.) = -2.0V and V_{IH} (max) = V_{CC} + 0.5V for pulse durations of less than 20 ns.
- Tested initially and after any design or process changes that may affect these parameters.

Thermal Resistance^[3]

Parameter	Description	Test Conditions	TSOP-II	FBGA	SOJ	Unit
Θ_{JA}	Thermal Resistance (Junction to Ambient)	Test conditions follow standard test methods and procedures for measuring thermal impedance, per EIA / JESD51.	42.96	38.15	25.99	°C/W
Θ_{JC}	Thermal Resistance (Junction to Case)		10.75	9.15	18.8	°C/W

AC Test Loads and Waveforms^[4]

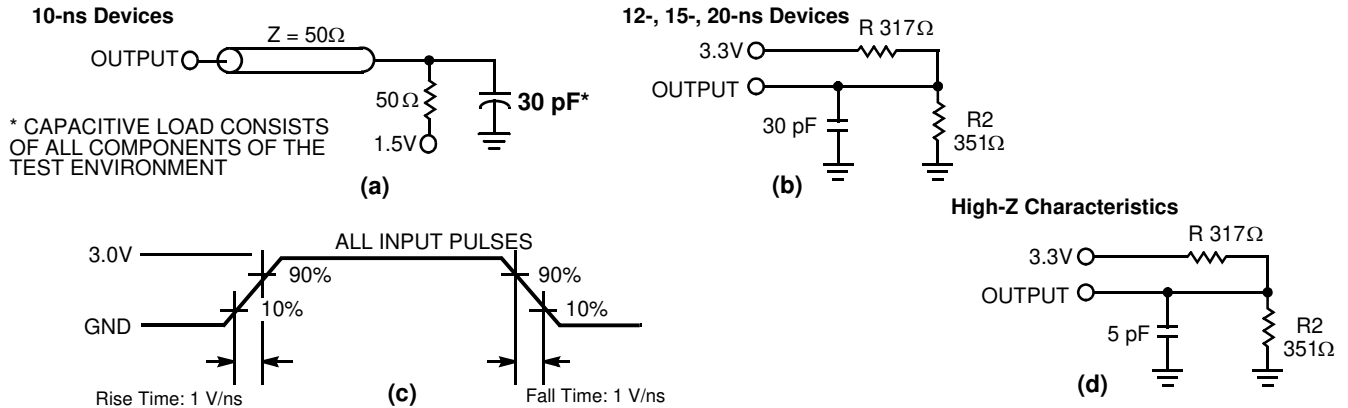

AC Switching Characteristics^[5] Over the Operating Range

Parameter	Description	-10		-12		-15		-20		Unit
		Min.	Max.	Min.	Max.	Min.	Max.	Min.	Max.	
Read Cycle										
$t_{power}^{[6]}$	V_{CC} (typical) to the first access	100		100		100		100		μs
t_{RC}	Read Cycle Time	10		12		15		20		ns
t_{AA}	Address to Data Valid		10		12		15		20	ns
t_{OHA}	Data Hold from Address Change	3		3		3		3		ns
t_{ACE}	\overline{CE} LOW to Data Valid		10		12		15		20	ns
t_{DOE}	\overline{OE} LOW to Data Valid		5		6		7		8	ns
t_{LZOE}	\overline{OE} LOW to Low-Z	0		0		0		0		ns
t_{HZOE}	\overline{OE} HIGH to High-Z ^[7, 8]		5		6		7		8	ns
t_{LZCE}	\overline{CE} LOW to Low-Z ^[8]	3		3		3		3		ns
t_{HZCE}	\overline{CE} HIGH to High-Z ^[7, 8]		5		6		7		8	ns
t_{PU}	\overline{CE} LOW to Power-Up	0		0		0		0		ns
t_{PD}	\overline{CE} HIGH to Power-Down		10		12		15		20	ns
t_{DBE}	Byte Enable to Data Valid		5		6		7		8	ns
t_{LZBE}	Byte Enable to Low-Z	0		0		0		0		ns
t_{HZBE}	Byte Disable to High-Z		6		6		7		8	ns

Notes:

- AC characteristics (except High-Z) for 10-ns parts are tested using the load conditions shown in Figure (a). All other speeds are tested using the Thevenin load shown in Figure (b). High-Z characteristics are tested for all speeds using the test load shown in Figure (d).
- Test conditions assume signal transition time of 3 ns or less, timing reference levels of 1.5V, input pulse levels of 0 to 3.0V.
- t_{power} gives the minimum amount of time that the power supply should be at typical V_{CC} values until the first memory access can be performed.
- t_{HZOE} , t_{HZCE} , and t_{HZWE} are specified with a load capacitance of 5 pF as in part (d) of AC Test Loads. Transition is measured ±500 mV from steady-state voltage.
- At any given temperature and voltage condition, t_{HZCE} is less than t_{LZCE} , t_{HZOE} is less than t_{LZOE} , and t_{HZWE} is less than t_{LZWE} for any given device.
- The internal Write time of the memory is defined by the overlap of \overline{CE} LOW, and \overline{WE} LOW. \overline{CE} and \overline{WE} must be LOW to initiate a Write, and the transition of either of these signals can terminate the Write. The input data set-up and hold timing should be referenced to the leading edge of the signal that terminates the Write.

AC Switching Characteristics^[5] Over the Operating Range (continued)

Parameter	Description	-10		-12		-15		-20		Unit
		Min.	Max.	Min.	Max.	Min.	Max.	Min.	Max.	
Write Cycle^[9, 10]										
t_{WC}	Write Cycle Time	10		12		15		20		ns
t_{SCE}	CE LOW to Write End	7		8		10		10		ns
t_{AW}	Address Set-Up to Write End	7		8		10		10		ns
t_{HA}	Address Hold from Write End	0		0		0		0		ns
t_{SA}	Address Set-Up to Write Start	0		0		0		0		ns
t_{PWE}	\overline{WE} Pulse Width	7		8		10		10		ns
t_{SD}	Data Set-Up to Write End	5		6		7		8		ns
t_{HD}	Data Hold from Write End	0		0		0		0		ns
t_{LZWE}	\overline{WE} HIGH to Low-Z ^[7]	3		3		3		3		ns
t_{HZWE}	\overline{WE} LOW to High-Z ^[7, 8]		5		6		7		8	ns
t_{BW}	Byte Enable to End of Write	7		8		10		10		ns

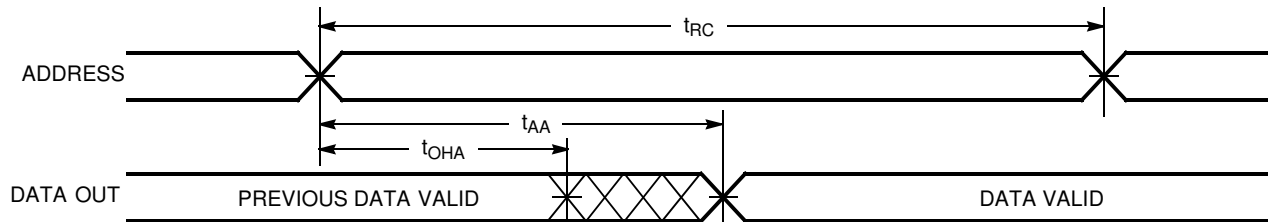
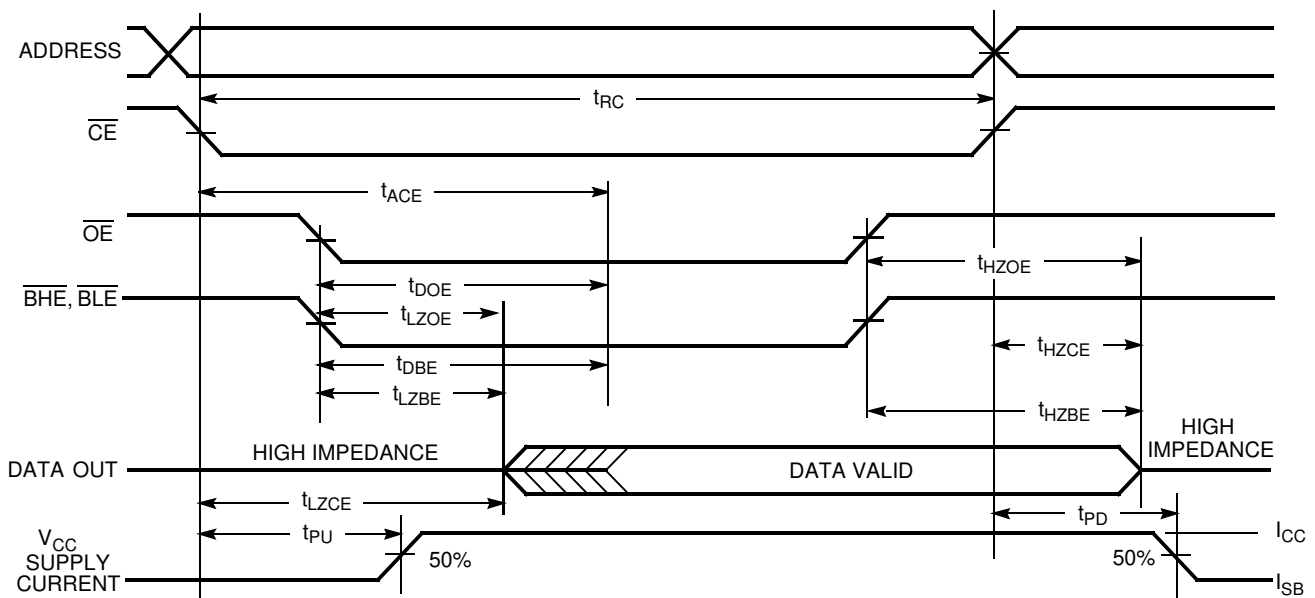
Switching Waveforms
Read Cycle No. 1^[11, 12]

Read Cycle No. 2 (\overline{OE} Controlled)^[12, 13]

Notes:

10. The minimum Write cycle time for Write Cycle No. 3 (\overline{WE} controlled, \overline{OE} LOW) is the sum of t_{HZWE} and t_{SD} .

11. Device is continuously selected. \overline{OE} , \overline{CE} , \overline{BHE} and/or $\overline{BLA} = V_{IL}$.

12. \overline{WE} is HIGH for Read cycle.

13. Address valid prior to or coincident with \overline{CE} transition LOW.

Switching Waveforms (continued)

Write Cycle No. 1 (\overline{CE} Controlled)^[14, 15]

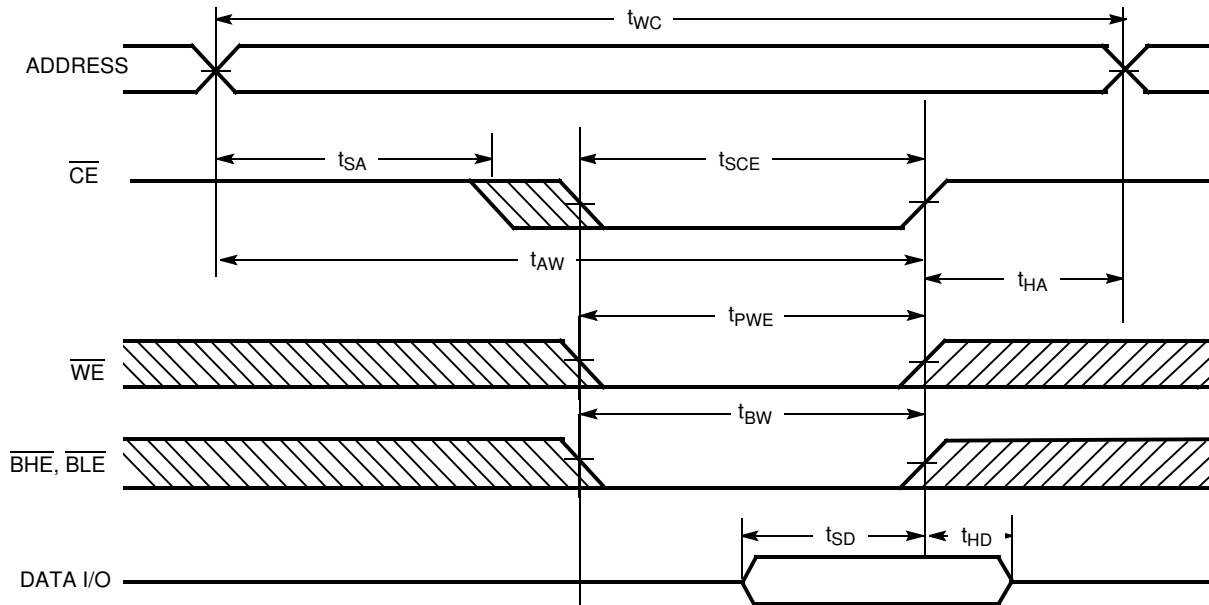

Write Cycle No. 2 (\overline{BLE} or \overline{BHE} Controlled)

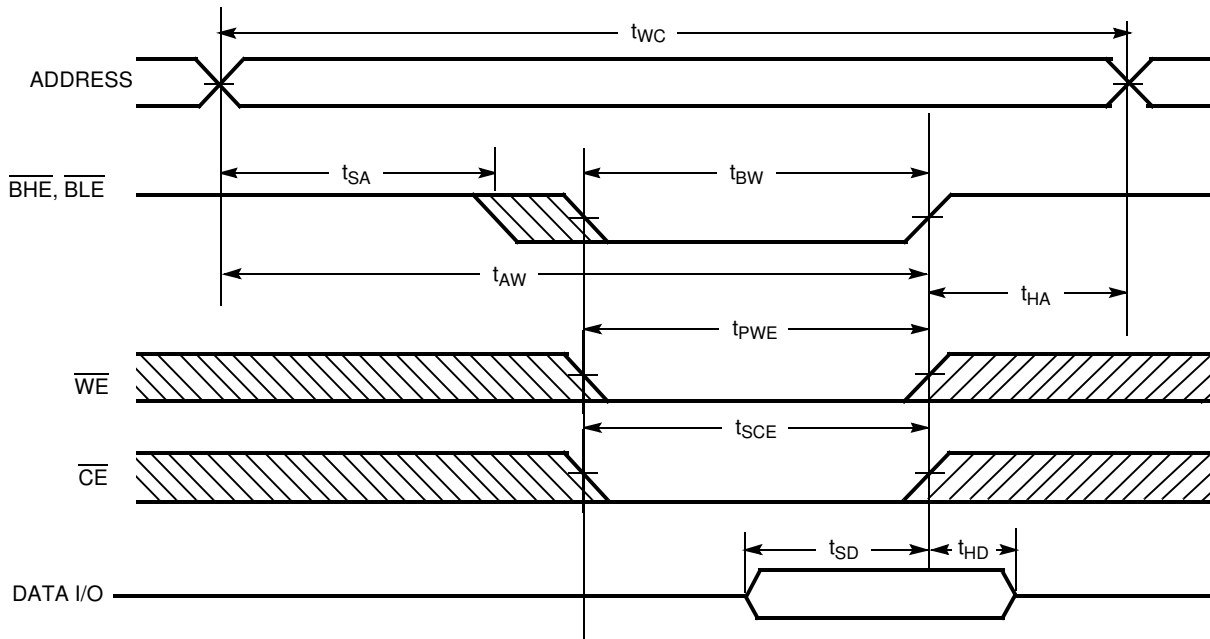

Notes:

- 14. Data I/O is high-impedance if \overline{OE} or \overline{BHE} and/or $\overline{BLE} = V_{IH}$.
- 15. If \overline{CE} goes HIGH simultaneously with \overline{WE} going HIGH, the output remains in a high-impedance state.

Switching Waveforms (continued)

Write Cycle No. 2 (\overline{WE} Controlled, \overline{OE} LOW)

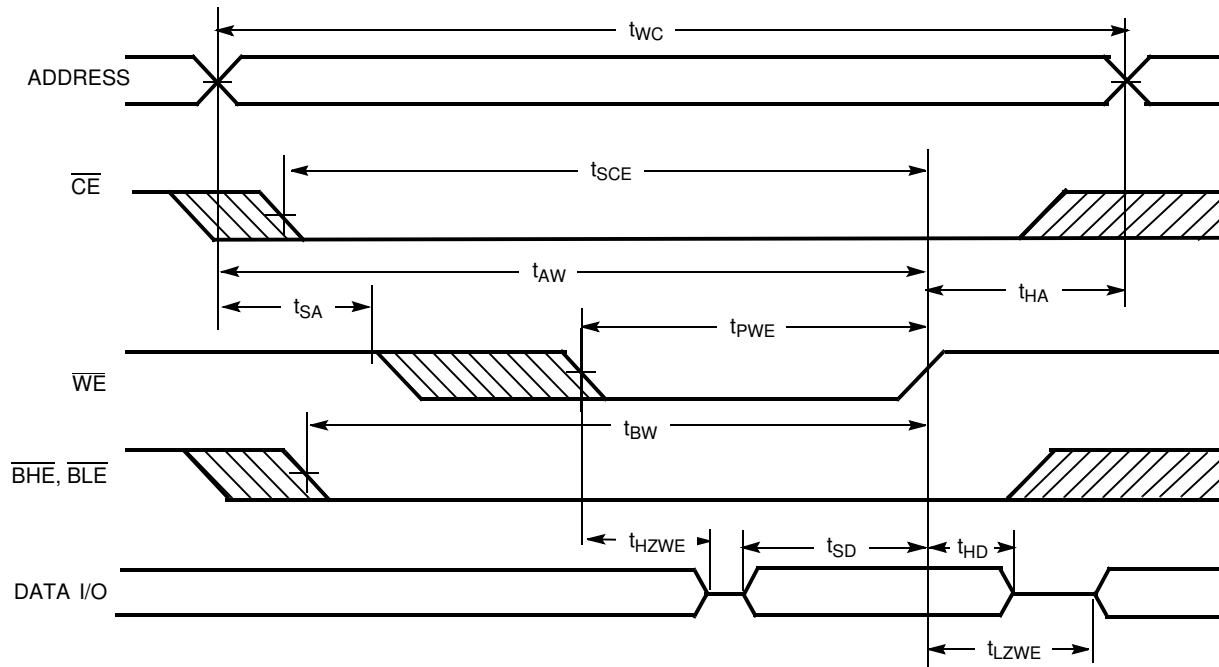

Truth Table

CE	OE	WE	BLE	BHE	I/O ₀ -I/O ₇	I/O ₈ -I/O ₁₅	Mode	Power
H	X	X	X	X	High-Z	High-Z	Power-down	Standby (I_{SB})
L	L	H	L	L	Data Out	Data Out	Read All Bits	Active (I_{CC})
L	L	H	L	H	Data Out	High-Z	Read Lower Bits Only	Active (I_{CC})
L	L	H	H	L	High-Z	Data Out	Read Upper Bits Only	Active (I_{CC})
L	X	L	L	L	Data In	Data In	Write All Bits	Active (I_{CC})
L	X	L	L	H	Data In	High-Z	Write Lower Bits Only	Active (I_{CC})
L	X	L	H	L	High-Z	Data In	Write Upper Bits Only	Active (I_{CC})
L	H	H	X	X	High-Z	High-Z	Selected, Outputs Disabled	Active (I_{CC})

Ordering Information

Speed (ns)	Ordering Code	Package Diagram	Package Type	Operating Range
10	CY7C1041CV33-10BAC	51-85106	48-ball Fine Pitch BGA	Commercial
	CY7C1041CV33-10BAXC		48-ball Fine Pitch BGA (Pb-Free)	
	CY7C1041CV33-10VC	51-85082	44-lead (400-mil) Molded SOJ	
	CY7C1041CV33-10VXC		44-lead (400-mil) Molded SOJ (Pb-Free)	
	CY7C1041CV33-10ZC	51-85087	44-pin TSOP II	
	CY7C1041CV33-10ZXC		44-pin TSOP II (Pb-Free)	
	CY7C1041CV33-10BAI	51-85106	48-ball Fine Pitch BGA	Industrial
	CY7C1041CV33-10BAXI		48-ball Fine Pitch BGA (Pb-Free)	
	CY7C1041CV33-10ZI	51-85087	44-pin TSOP II	
	CY7C1041CV33-10ZXI		44-pin TSOP II (Pb-Free)	
	CY7C1041CV33-10ZSXA		44-pin TSOP II (Pb-Free)	Automotive-A
	CY7C1041CV33-10BAXA	51-85106	48-ball Fine Pitch BGA (Pb-Free)	
12	CY7C1041CV33-12VC	51-85082	44-lead (400-mil) Molded SOJ	Commercial
	CY7C1041CV33-12VXC		44-lead (400-mil) Molded SOJ (Pb-Free)	
	CY7C1041CV33-12ZC	51-85087	44-pin TSOP II	
	CY7C1041CV33-12ZXC		44-pin TSOP II (Pb-Free)	
	CY7C1041CV33-12VXI	51-85082	44-lead (400-mil) Molded SOJ (Pb-Free)	Industrial
	CY7C1041CV33-12ZI	51-85087	44-pin TSOP II	
	CY7C1041CV33-12ZXI		44-pin TSOP II (Pb-Free)	
15	CY7C1041CV33-15VC	51-85082	44-lead (400-mil) Molded SOJ	Commercial
	CY7C1041CV33-15VXC		44-lead (400-mil) Molded SOJ (Pb-Free)	
	CY7C1041CV33-15ZC	51-85087	44-pin TSOP II	
	CY7C1041CV33-15ZXC		44-pin TSOP II (Pb-Free)	
	CY7C1041CV33-15VI	51-85082	44-lead (400-mil) Molded SOJ	Industrial
	CY7C1041CV33-15VXI		44-lead (400-mil) Molded SOJ (Pb-Free)	
	CY7C1041CV33-15ZI	51-85087	44-pin TSOP II	
	CY7C1041CV33-15ZXI		44-pin TSOP II (Pb-Free)	
20	CY7C1041CV33-20ZC	51-85087	44-pin TSOP II	Commercial
	CY7C1041CV33-20ZXC		44-pin TSOP II (Pb-Free)	
	CY7C1041CV33-20ZSXA		44-pin TSOP II (Pb-Free)	Automotive-A
	CY7C1041CV33-20VE	51-85082	44-lead (400-mil) Molded SOJ	Automotive-E
	CY7C1041CV33-20VXE		44-lead (400-mil) Molded SOJ (Pb-Free)	
	CY7C1041CV33-20ZE	51-85087	44-pin TSOP II	
	CY7C1041CV33-20ZSXE		44-pin TSOP II (Pb-Free)	

Please contact your local Cypress sales representative for availability of these parts

Package Diagrams

48-Ball (7.00 mm x 8.50 mm x 1.2 mm) FBGA (51-85106)

TOP VIEW

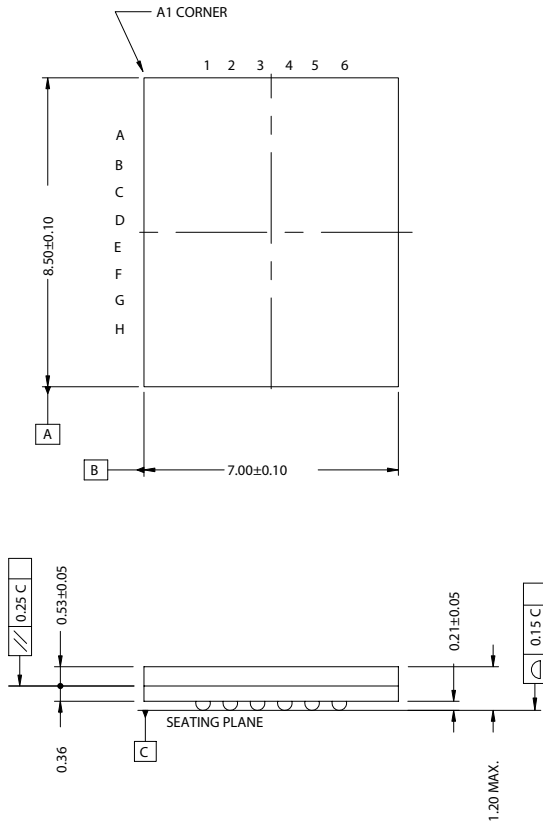

BOTTOM VIEW

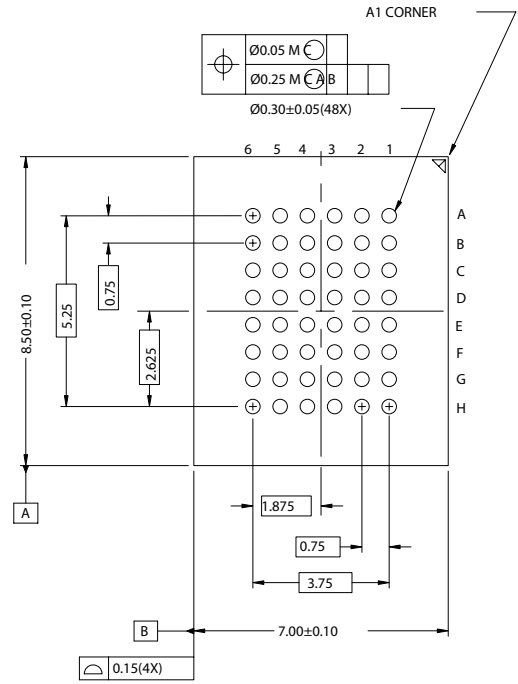

51-85106-*E

Package Diagrams (continued)

44-lead (400-mil) Molded SOJ (51-85082)

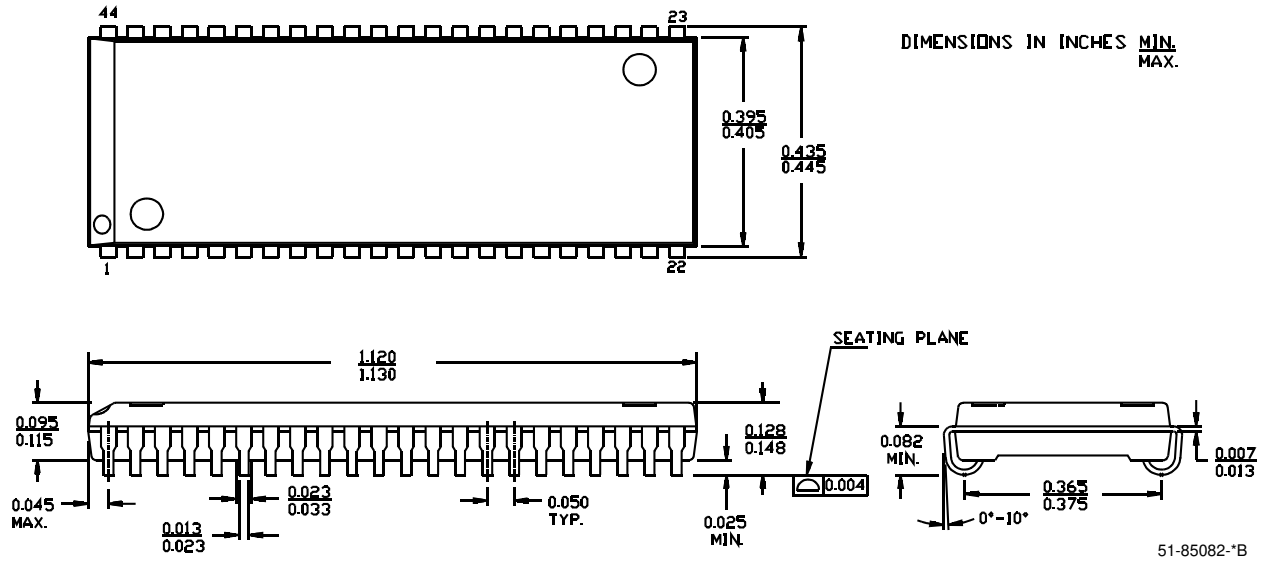

44-pin TSOP II (51-85087)

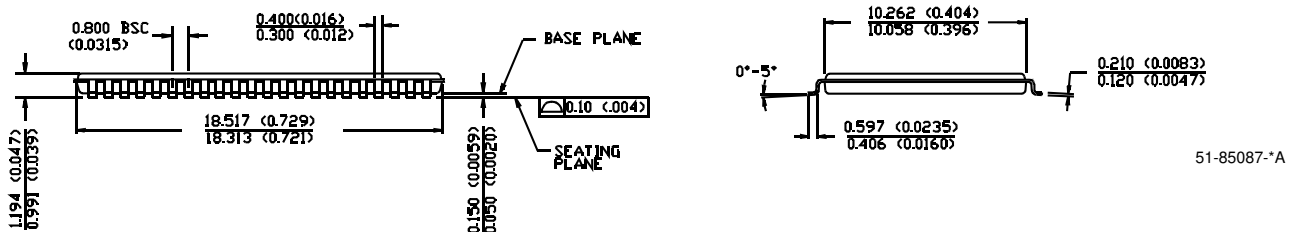
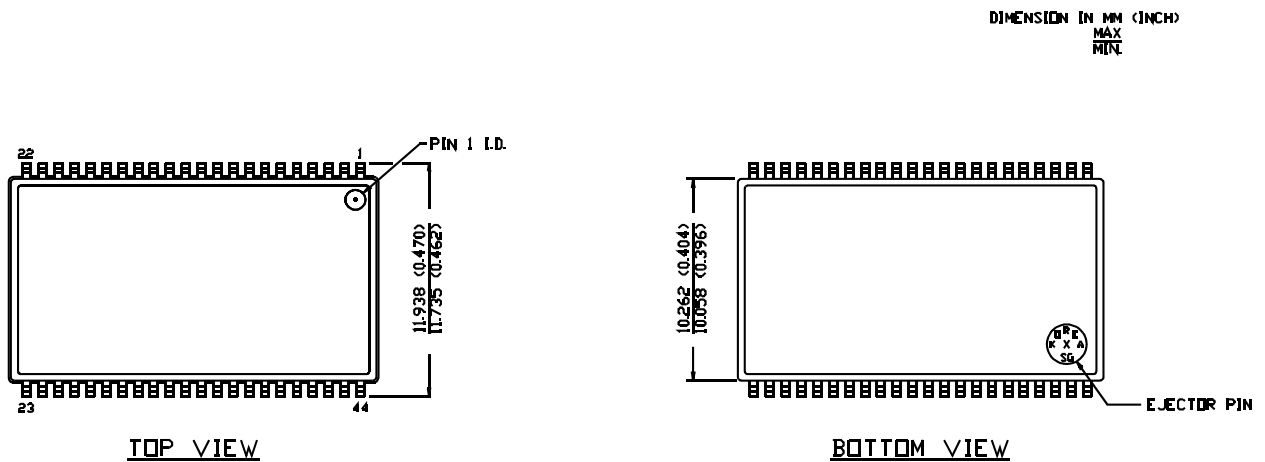

All products and company names mentioned in this document may be the trademarks of their respective holders.

Document History Page

Document Title: CY7C1041CV33 4-Mbit (256K x 16) Static RAM				
Document Number: 38-05134				
REV.	ECN NO.	Issue Date	Orig. of Change	Description of Change
**	109513	12/13/01	HGK	New Data Sheet
*A	112440	12/20/01	BSS	Updated 51-85106 from revision *A to *C
*B	112859	03/25/02	DFP	Added CY7C1042CV33 in BGA package Removed 1042 BGA option pin ACC Final Data Sheet
*C	116477	09/16/02	CEA	Add applications foot note to data sheet
*D	119797	10/21/02	DFP	Added 20-ns speed bin
*E	262949	See ECN	RKF	1) Added Lead (Pb)-Free parts in the Ordering info (Page #9) 2) Added Automotive Specs to Datasheet
*F	361795	See ECN	SYT	Added Pb-Free offerings in the Ordering Information
*G	435387	See ECN	NXR	Removed -8 Speed bin from Product offering. Corrected typo in description for BHE/BLE in pin definitions table on Page# 3 corrected ther Pin name from OE2 to OE. Included the Maximum Ratings for Static Discharge Voltage and Latch up Current. Changed the description of I _{IX} current from Input Load Current to Input Leakage Current Added note# 4 on page# 4 Updated the Ordering Information table
*H	499153	See ECN	NXR	Added Automotive-A Operating Range Changed t _{power} value from 1 μs to 100 μs Updated Ordering Information table