



## ■ BlueChip PLC Evaluation board Manual

### **Dolphin BCP-STD for PLC**

BCP-CP-E01 : Evaluation board (Dolphin STD)

2016/03/29

**Proprietary MegaChips Corporation**



## ■ Table of contents

- EVALUATION KIT IMPORTANT NOTICE
- BlueChip PLC Evaluation board contents
- OutlineView
- Detail
- Jumper-pin Setting
- Tx Power Setting
- AC/DC adapter
- BCP-COAX\_CONV Board (Coupler)
- Connection Diagram (Ether Bridge Test with DC power line)
- Connection Diagram (Ether Bridge Test with Coax.)
- Connection Diagram (Ether Bridge Test with AC power line)
- Connection Diagram (RS485 Bridge Test)
- Connection Diagram (Multi-hop Test)

## ■ EVALUATION KIT IMPORTANT NOTICE

MegaChips Corporation (MCC) provides these evaluation kits (EVKs) under the following **AS IS** conditions:

The EVKs are intended for use for **ENGINEERING DEVELOPMENT OR EVALUATION PURPOSES ONLY** and are not for commercial use. Therefore, the EVKs are not fault-tolerant and are not designed or manufactured with protective considerations, including but not limited to product safety measures typically found in finished commercial goods. As a prototype, the EVKs do not fall within the scope of the European Union Directive on electromagnetic compatibility. Also be aware that the EVKs may not be regulatory compliant or agency certified (FCC, UL, CE, etc.).

The EVKs have **110/220VAC POWER DIRECTLY CONNECTED TO THEIR CIRCUITS, which can cause PERSONAL INJURY, DEATH OR PHYSICAL DAMAGE**. Therefore, caution should be exercised when testing these devices. The user must be a skilled person in the practice and art of high voltage circuitry in order to utilize the circuits in the EVKs. It is highly recommended that the user should have qualifications or any certificate for handling 110/220VAC Power, **COMMON SENSE IS ENCOURAGED**. The user agree not to use the EVKs in any situation where damage or injury to persons, property or business could occur. Furthermore, the EVKs are **NOT FOR RESALE/COMMERCIAL USE AND MUST BE STRICTLY OPERATED IN A WELL-CONTROLLED LABORATORY ENVIRONMENTS**.

**THE USER ASSUMES ALL RESPONSIBILITY AND LIABILITY FOR PROPER AND SAFE HANDLING OF THE EVKS. FURTHER, THE USER RELEASES MCC FROM ALL CLAIMS ARISING FROM THE HANDING OR USE OF THE EVKS.**

This notice contains important safety information as to handling EVKs. For further safety concerns, please contact a MCC application engineer.

# BlueChip PLC Evaluation board contents(1/2)

## 1. Dolphin BCP-STD Master/Terminal set



① Packaging box :1pcs

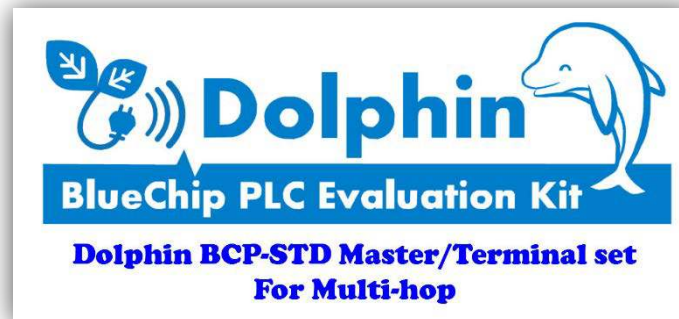

② EVALUATION KIT IMPORTANT NOTICE :1pcs

③ Multi-hop Master unit :1pcs

④ Multi-hop Terminal unit :1pcs

⑤ AC adapter(DC12V) :2pcs

⑥ Connector Plug for RS485 Port Connector  
MC 1,5/ 3-ST-3,5(PhoenixContact) :2pcs

⑦ Connector Plug for PLC Interface Connector  
MSTB 2,5/ 2-ST(PhoenixContact) :4pcs

⑧ BCP-COAX\_CONV Board :2pcs

## BlueChip PLC Evaluation board contents(2/2)

### 2. Dolphin BCP-STD Terminal/Terminal set



① Packaging box :1pcs



② EVALUATION KIT IMPORTANT NOTICE :1pcs

③ Multi-hop Master unit :0pcs

④ Multi-hop Terminal unit :2pcs

⑤ AC adapter(DC12V) :2pcs

⑥ Connector Plug for RS485 Port Connector :2pcs

MC 1,5/ 3-ST-3,5(PhoenixContact)

⑦ Connector Plug for PLC Interface Connector :4pcs

MSTB 2,5/ 2-ST(PhoenixContact)

⑧ BCP-COAX\_CONV Board :2pcs

## ■ Outline View

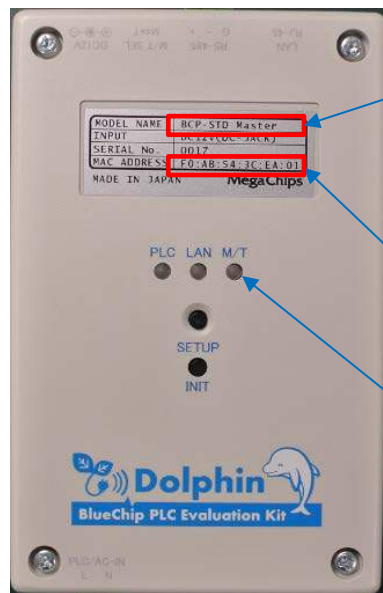
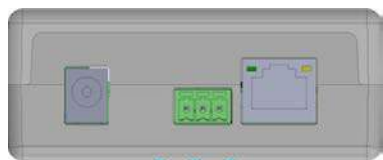

Label :  
BCP-STD(Master)

MAC ADDRESS

M/T LED : Green ON

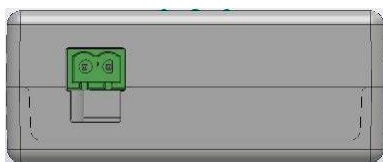

Master unit

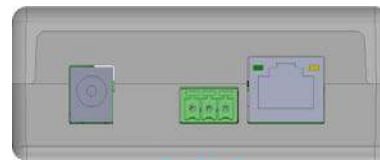

Label :  
BCP-STD(Terminal)

MAC ADDRESS

M/T LED : Green OFF

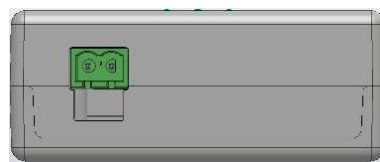

Terminal unit

# Detail

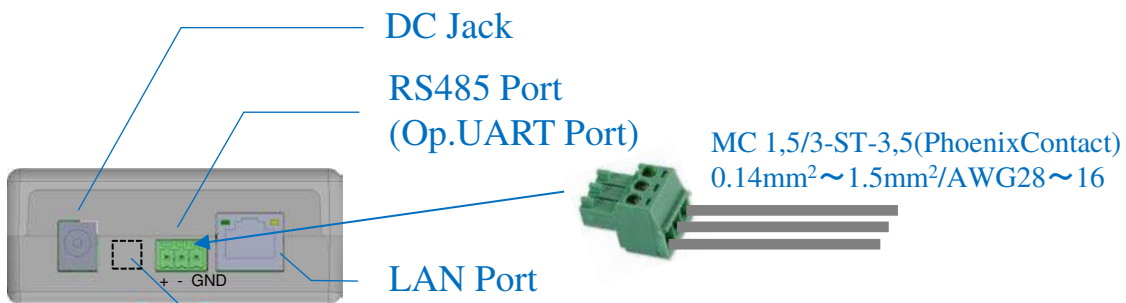

DC Jack

RS485 Port  
(Op. UART Port)

MC 1,5/3-ST-3,5(PhoenixContact)  
0.14mm<sup>2</sup>~1.5mm<sup>2</sup>/AWG28~16

LAN Port

N/A

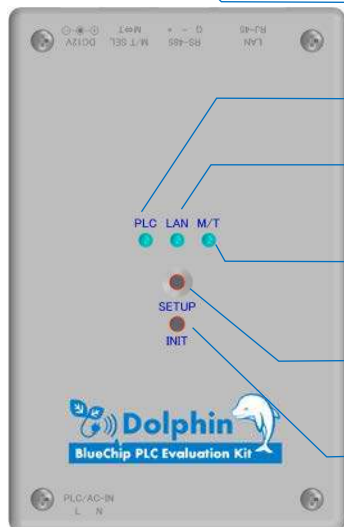

PLC LED : PLC Link status

LAN LED : LAN status

M/T LED : Master mode :Green ON  
Terminal mode :Green OFF

SETUP button : **Power-up with holding SETUP pressed will change the Master/Terminal mode.**

INIT button : Reset to factory default (push at least 1second)

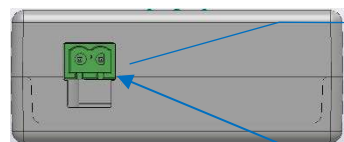

PLC Interface Connector  
(Op. AC Input Connector)



MSTB 2,5/ 2-ST(PhoenixContact)  
0.2mm<sup>2</sup>~2.5mm<sup>2</sup>/AWG24~12



Case Size  
32mm(H) × 80mm(W) × 125mm(D)

## ■ Jumper-pin Setting(1/2)

### (1) Power Input Source Setting

No.	Power Input Source	JP100/JP101
1*	DC12V from CN200(DC-JACK)	OPEN
2	AC100~AC240V from CN100	SHORT

\*Default Setting

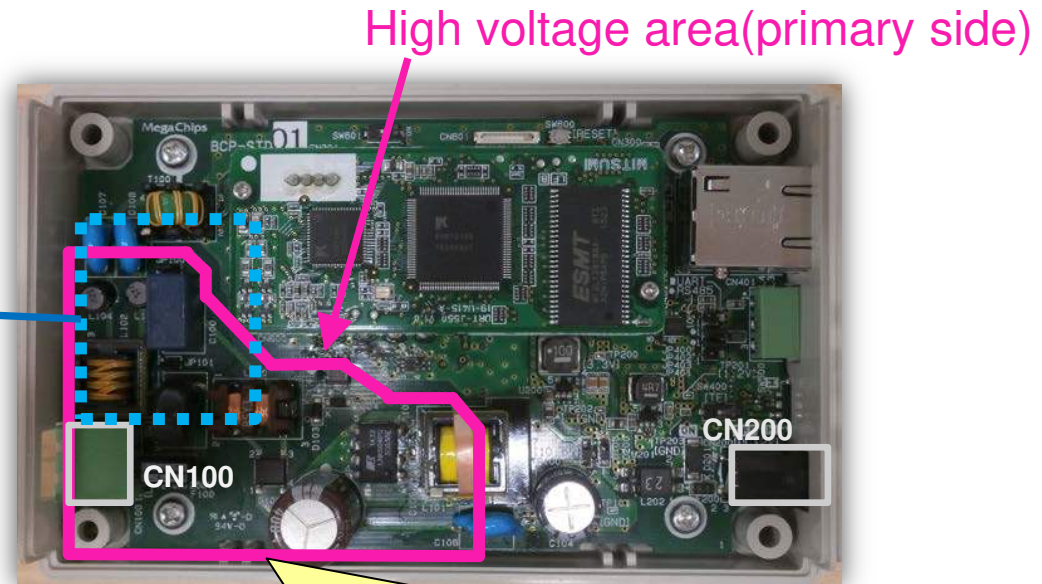
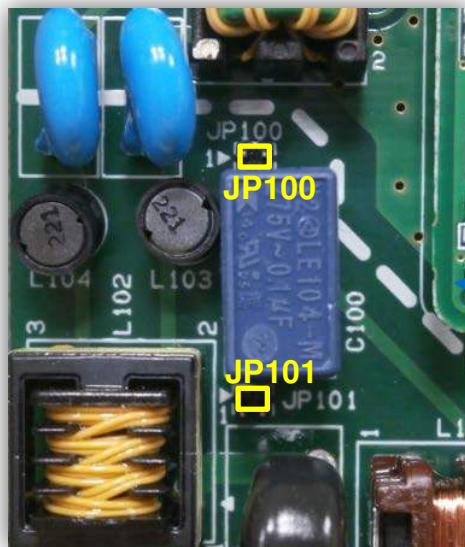

### Warning!!

When JP100/101 is short, this area is directly connected to the input power (high voltage : AC100V-AC240V). Therefore, please do NOT touch this area while connected to the AC power line.



# Jumper-pin Setting(2/2)

## (2)CN401 Interface Setting

No.	CN401 Interface	JP400 JP401	JP402 JP403	R410
1*	RS485	OPEN	SHORT	22Ω
2	UART	SHORT	OPEN	Non-mounted

\*Default Setting

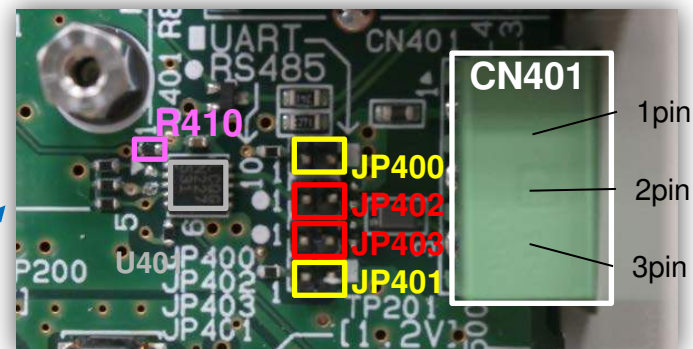

### CN401 Pin assignment

Pin	Case Silk	RS485 mode	UART Mode
1	G	GND	GND
2	-	TxD-/RxD-	RXD (input)
3	+	TxD+/RxD+	TXD (output)

# ■ Tx Power Setting(1/2)

This unit has two power control tables as below.  
Refer to next page about how to change the tables.

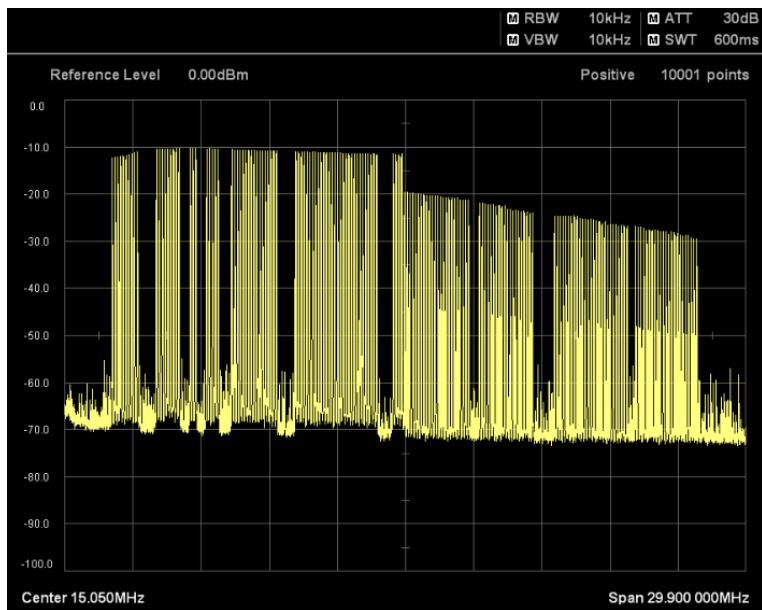

【Table index 0】(Default)

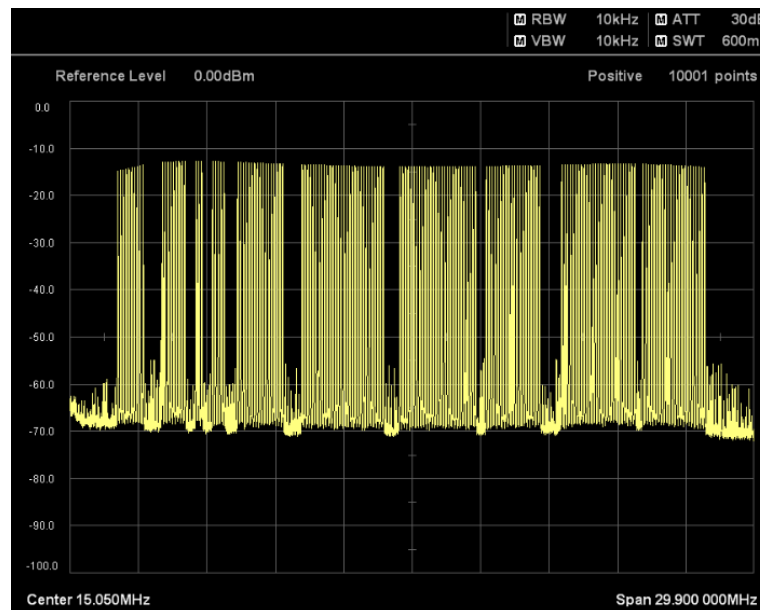

【Table index 1】

# ■Tx Power Setting(2/2)

## How to change the table index by “HD-PLC ToolManager”

- (1)Start the “HD-PLC Tool Manager”
  - \*Refer to “PTT-D0013E\_ToolManager [Power Control] Manual (NDA Required).pdf” for the detailed usage.
- (2)Click “Option” button.
- (3)Select the table index, and Click “OK” button.
  - index 0\* : for Japan (\*:Default Setting)
  - index 1 : Full power setting
  - index 2-7 : N/A
  - index 8,9 : Reserved
- (4)Input **password “1234567890”**, and click “OK” button.
  - >The following message is displayed.

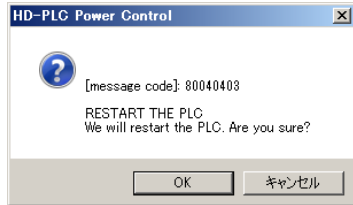
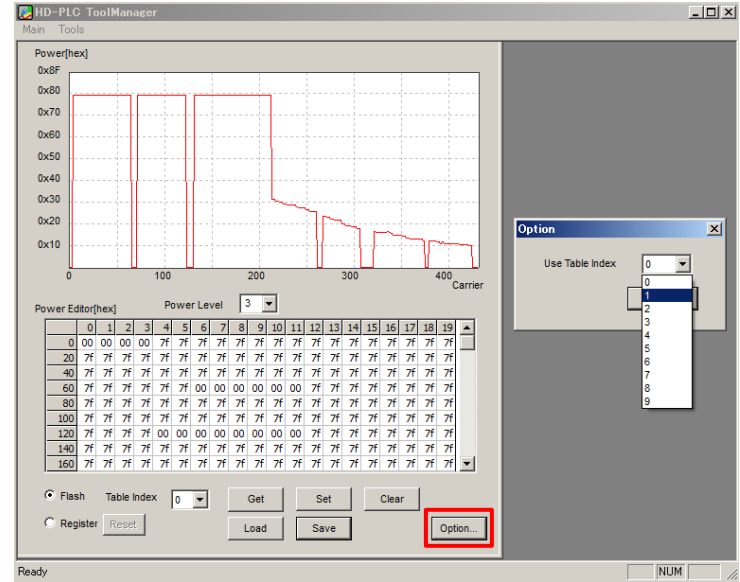

- (5)If you want to restart, click “OK” button.
  - >Then restart will be started.

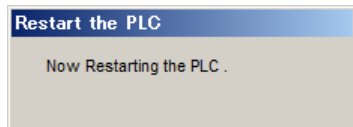

# ■ AC/DC adapter

Maker : CUI  
ModelNo : SMI6-12-V-P5  
INPUT : 100-240V(47Hz-63Hz)  
OUTPUT : DC12V/0.5A



units: mm  
tolerance:  $\pm 1$  mm

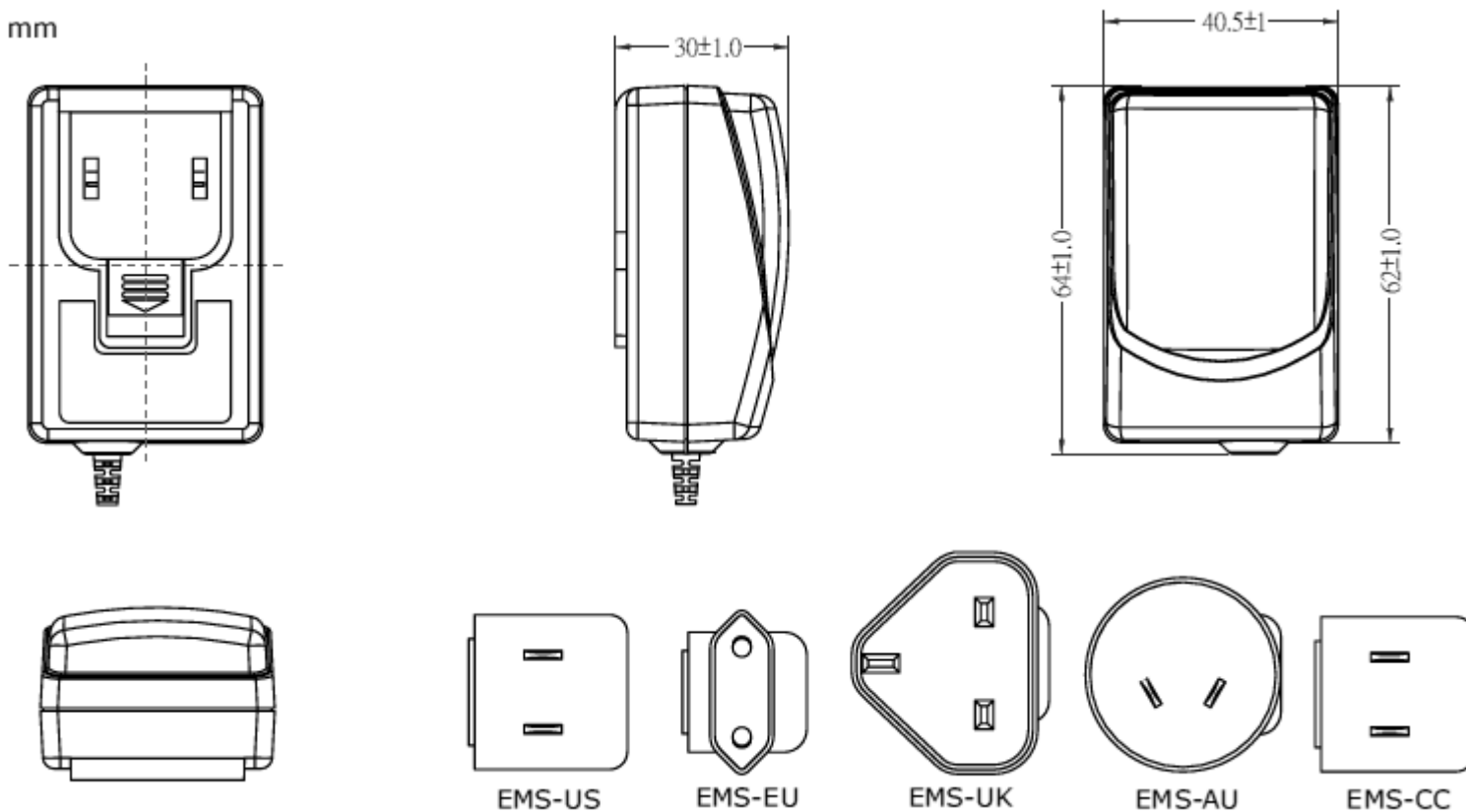

# ■ BCP-COAX\_CONV Board (Coupler)

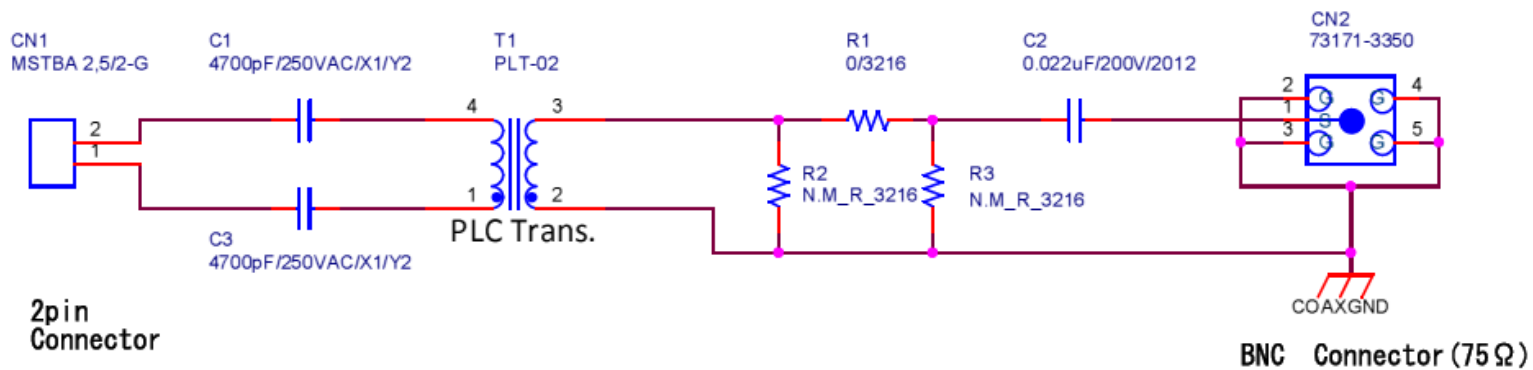

# ■ Connection Diagram (Ether Bridge Test with DC power line)

- (1) Connect Ethernet Devices
- (2) Start Test

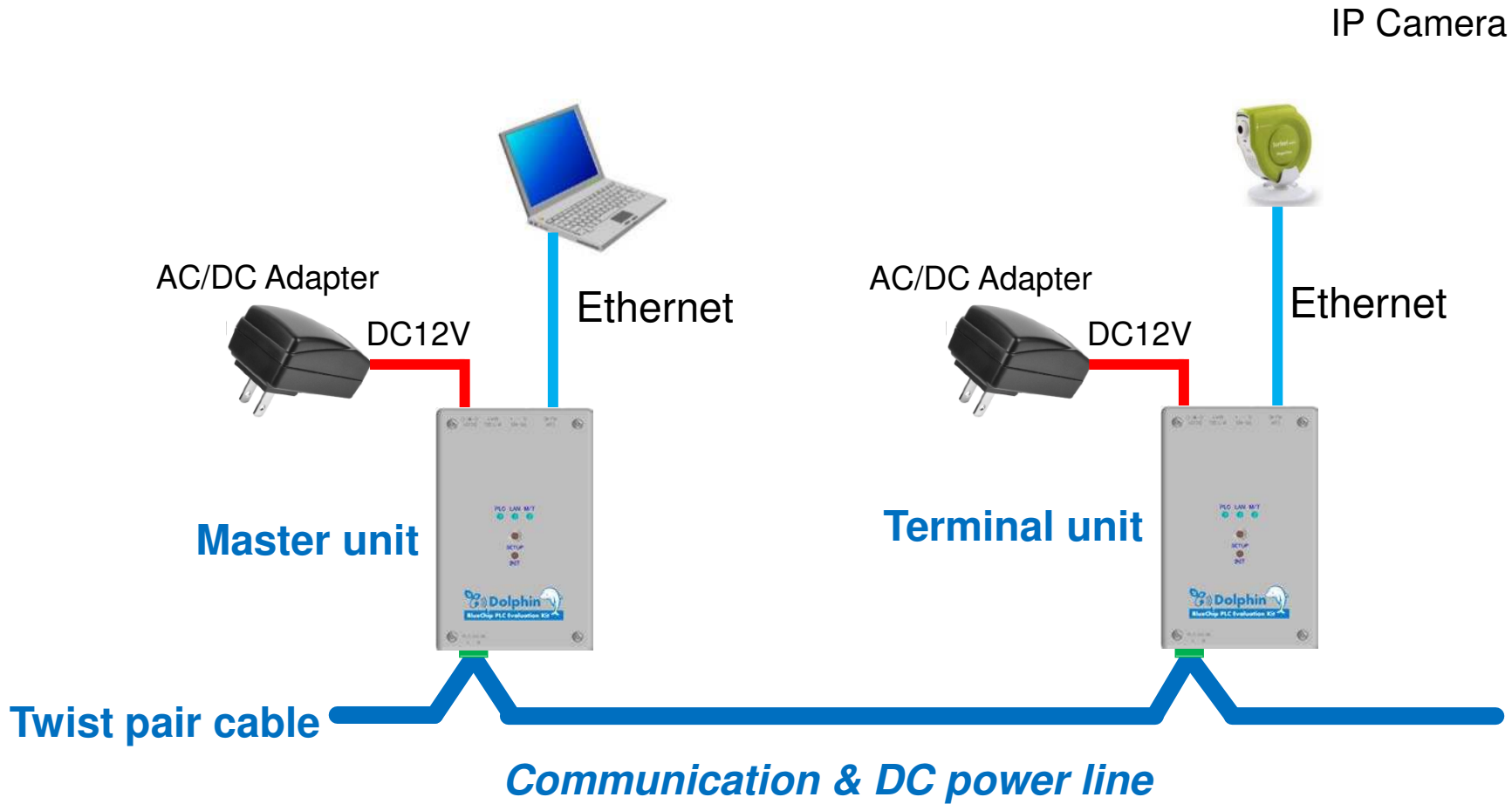

## ■ Connection Diagram (Ether Bridge Test with Coax.)

- (1) Connect Ethernet Devices
- (2) Start Test

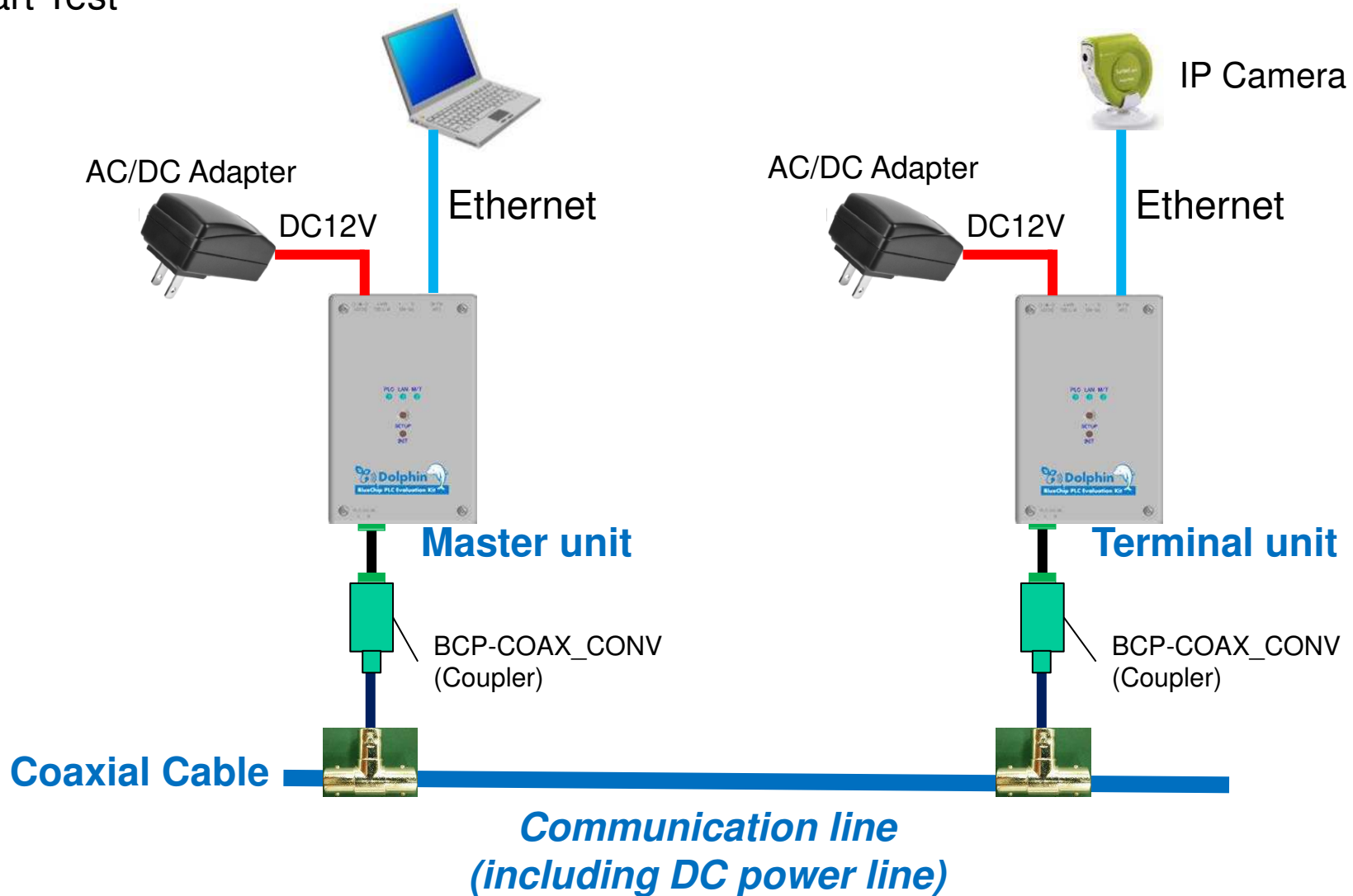

## ■ Connection Diagram (Ether Bridge Test with AC power line)

- (1) Connect Ethernet Devices
- (2) Start Test

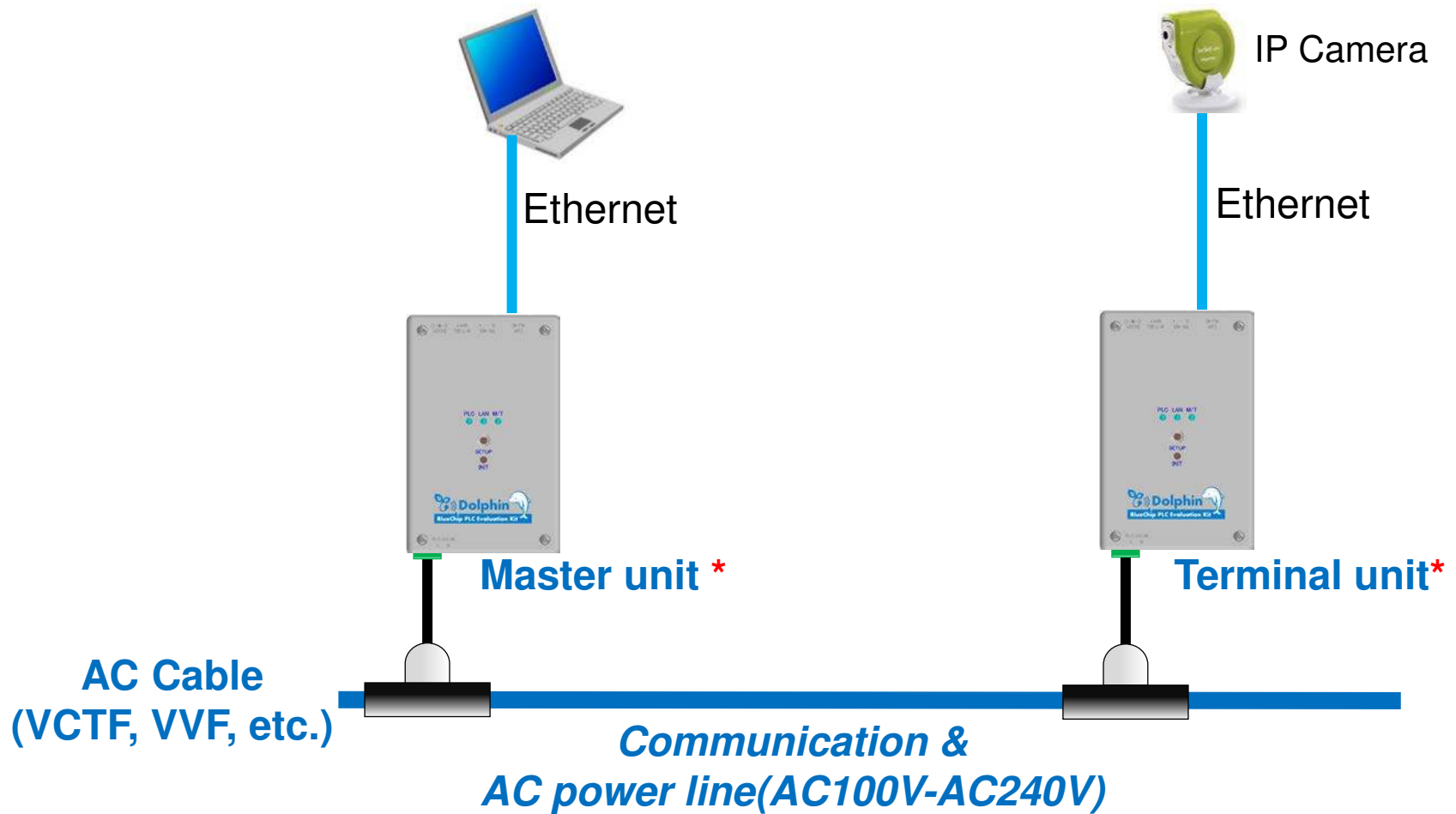

\* Change Power Input Source Setting (See P.7)



## ■ Connection Diagram (RS485 Bridge Test)

- (1) Connect RS485 Devices
- (2) Set RS485 parameters (Baud Rate, Address, etc.) by BCPNM  
(Default : Baud rate:115200bps, Data:8bit, Parity:None, Stop:1bit)
- (3) Start Test

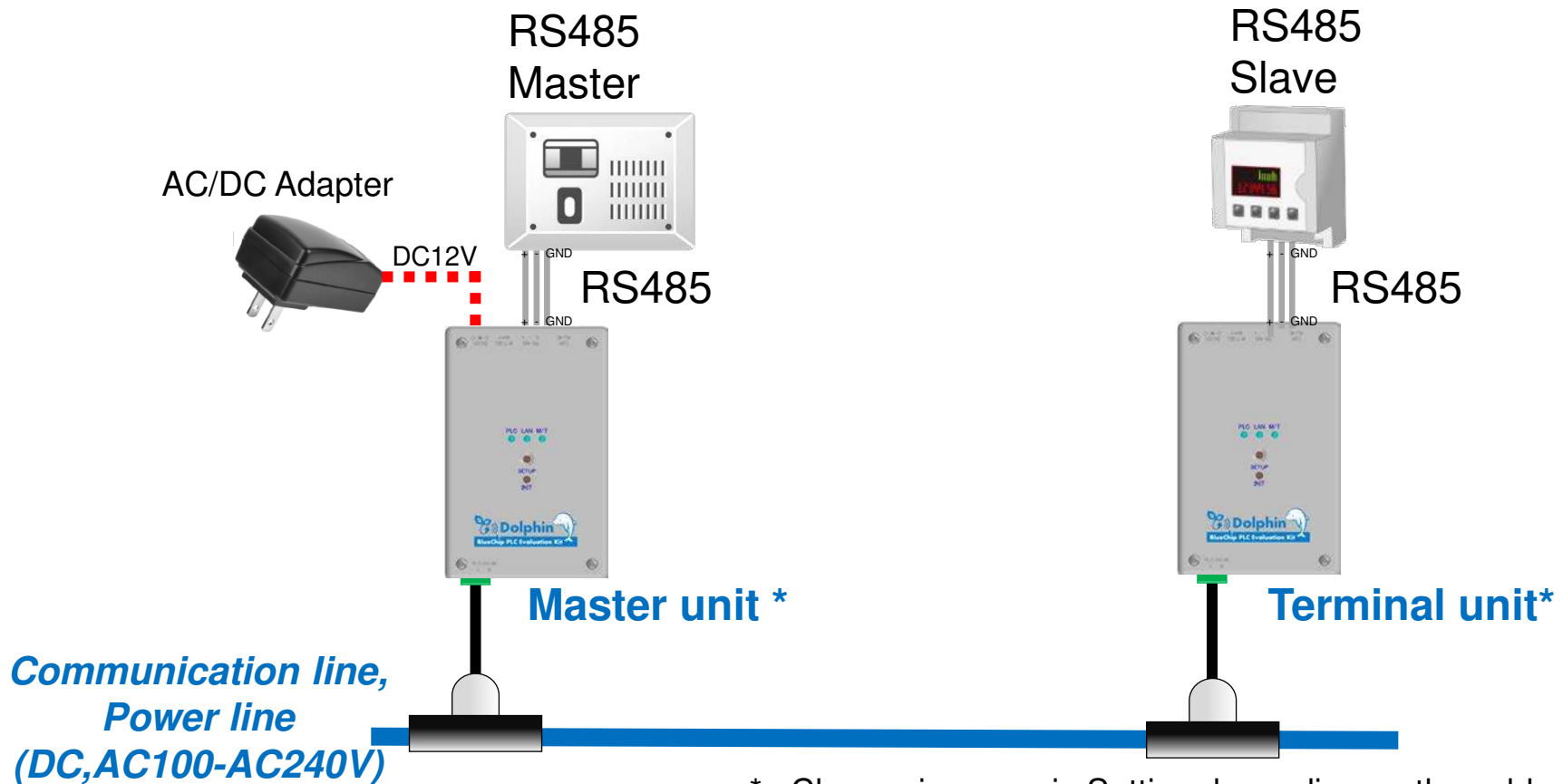

\* : Change jumper-pin Setting depending on the cable.  
(See P.7-8).

## ■ Connection Diagram (Multi-hop Test)

- (1) Connect devices such as below
- (2) Start Test

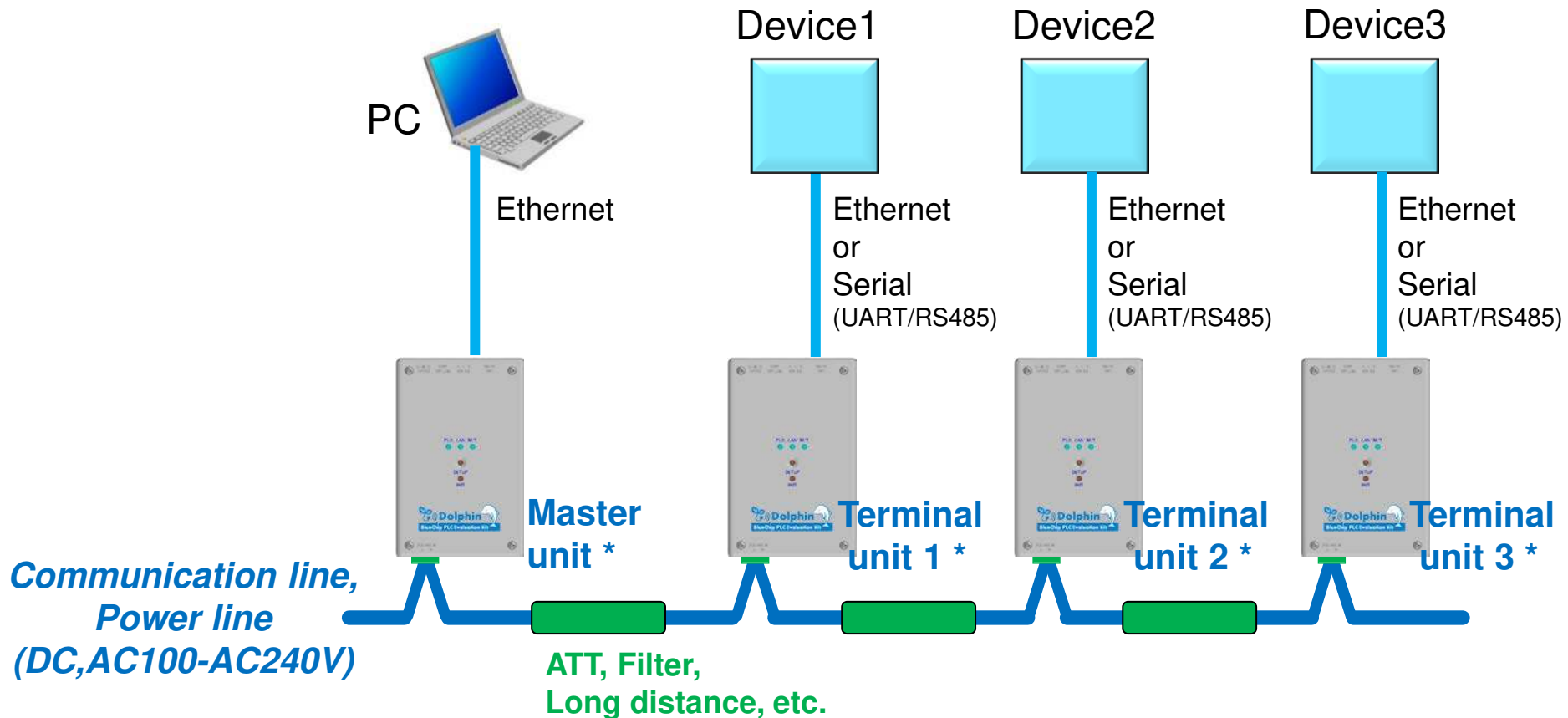

\* : Change jumper-pin Setting depending on the cable and serial interface.(See P.7-8).