



LOW-VOLTAGE DUAL 1-OF-4 MULTIPLEXER/ DEMULTIPLEXER

IDT74CBTLV3253

FEATURES:

- Functionally equivalent to QS3253
- 5Ω bi-directional switch connection between two ports
- Isolation under power-off conditions
- Over-voltage tolerant
- Latch-up performance exceeds 100mA
- $V_{CC} = 2.3V - 3.6V$, Normal Range
- ESD > 2000V per MIL-STD-883, Method 3015;
> 200V using machine model (C = 200pF, R = 0)
- Available in QSOP and TSSOP packages

DESCRIPTION:

The CBTLV3253 is a dual 1-of-4 high-speed multiplexer/demultiplexer. The low on-state resistance of the switch allows connections to be made with minimal propagation delay.

The select (S0, S1) input controls the data flow. The multiplexer/demultiplexer switches are disabled when the output-enable (\overline{OE}) input is high.

To ensure that the device is in high-impedance state during power up or power down, \overline{OE} should be tied to V_{CC} through a pullup resistor; the minimum value of the resistor is determined by the current-sinking capability of the driver.

FUNCTIONAL BLOCK DIAGRAM

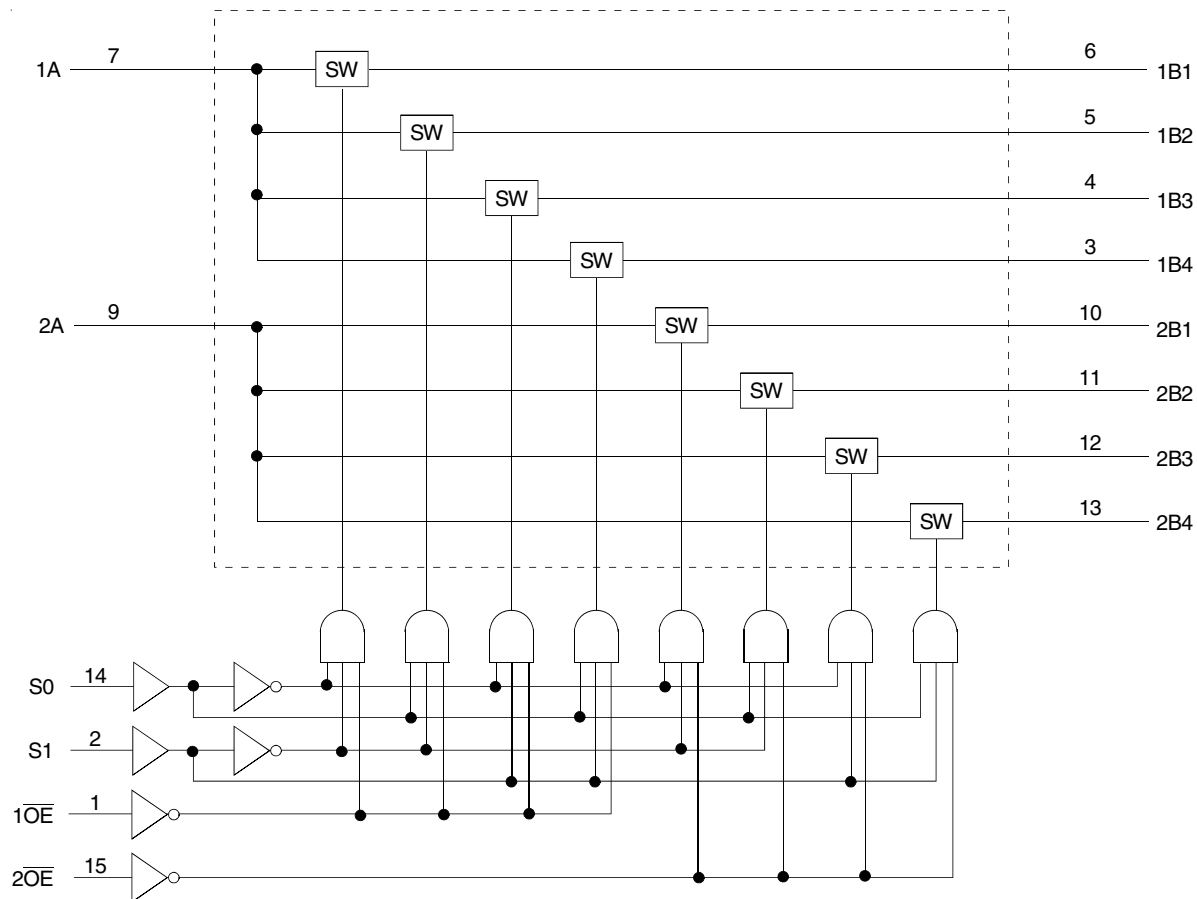

PIN CONFIGURATION

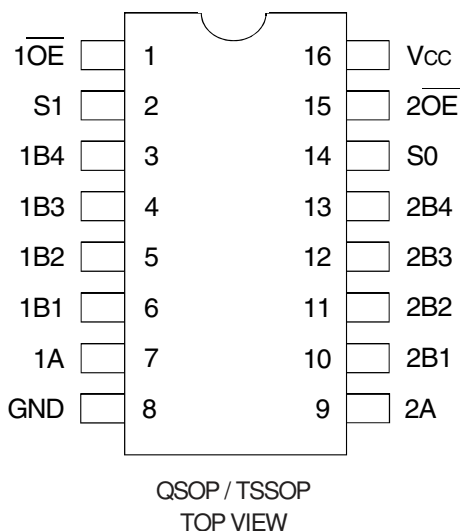

ABSOLUTE MAXIMUM RATINGS⁽¹⁾

Symbol	Description	Max	Unit
V _{cc}	Supply Voltage Range	-0.5 to +4.6	V
V _I	Input Voltage Range	-0.5 to +4.6	V
	Continuous Channel Current	128	mA
I _{IK}	Input Clamp Current, V _{I/O} < 0	-50	mA
T _{STG}	Storage Temperature	-65 to +150	°C

NOTE:

1. Stresses greater than those listed under ABSOLUTE MAXIMUM RATINGS may cause permanent damage to the device. This is a stress rating only and functional operation of the device at these or any other conditions above those indicated in the operational sections of this specification is not implied. Exposure to absolute maximum rating conditions for extended periods may affect reliability.

SIMPLIFIED SCHEMATIC, EACH SWITCH

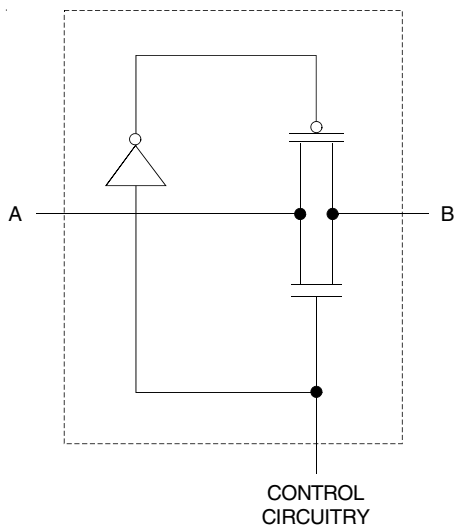

FUNCTION TABLE⁽¹⁾

ONE OF TWO 1:4 MUX/DEMUX BANKS

Inputs			Function
\overline{OE}	S1	S0	
L	L	L	A Port = B1 Port
L	L	H	A Port = B2 Port
L	H	L	A Port = B3 Port
L	H	H	A Port = B4 Port
H	X	X	Disconnect

NOTE:

1. H = HIGH Voltage Level
L = LOW Voltage Level
X = Don't Care

OPERATING CHARACTERISTICS, T_A = 25°C⁽¹⁾

Symbol	Parameter	Test Conditions	Min.	Max.	Unit
V _{cc}	Supply Voltage		2.3	3.6	V
V _{IH}	High-Level Control Input Voltage	V _{cc} = 2.3V to 2.7V	1.7	—	V
		V _{cc} = 2.7V to 3.6V	2	—	
V _{IL}	Low-Level Control Input Voltage	V _{cc} = 2.3V to 2.7V	—	0.7	V
		V _{cc} = 2.7V to 3.6V	—	0.8	
T _A	Operating Free-Air Temperature		-40	85	°C

NOTE:

1. All unused control inputs of the device must be held at V_{cc} or GND to ensure proper device operation.

DC ELECTRICAL CHARACTERISTICS OVER OPERATING RANGE

Following Conditions Apply Unless Otherwise Specified:

Operating Conditions: $T_A = -40^{\circ}\text{C}$ to $+85^{\circ}\text{C}$

Symbol	Parameter	Test Conditions		Min.	Typ. ⁽¹⁾	Max.	Unit
V_{IK}	Control Inputs, Data Inputs	$V_{CC} = 3V$, $I_I = -18\text{mA}$		—	—	-1.2	V
I_I	Control Inputs	$V_{CC} = 3.6V$, $V_I = V_{CC}$ or GND		—	—	± 1	μA
I_{OZ}	Data I/O	$V_{CC} = 3.6V$, $V_O = 0$ or $3.6V$, switch disabled		—	—	5	μA
I_{OFF}		$V_{CC} = 0$, V_I or $V_O = 0$ to $3.6V$		—	—	50	μA
I_{CC}		$V_{CC} = 3.6V$, $I_O = 0$, $V_I = V_{CC}$ or GND		—	—	10	μA
$\Delta I_{CC}^{(2)}$	Control Inputs	$V_{CC} = 3.6V$, one input at $3V$, other inputs at V_{CC} or GND		—	—	300	μA
C_I	Control Inputs	$V_I = 3V$ or 0		—	4	—	pF
$C_{IO(OFF)}$	A Port	$V_O = 3V$ or 0 , $\overline{OE} = V_{CC} = 3.3V$		—	20	—	pF
	B Port			—	6	—	
$R_{ON}^{(3)}$	$V_{CC} = 2.3V$ Typ. at $V_{CC} = 2.5V$	$V_I = 0$	$I_O = 64\text{mA}$	—	5	8	Ω
			$I_O = 24\text{mA}$	—	5	8	
		$V_I = 1.7V$	$I_O = 15\text{mA}$	—	27	40	
	$V_{CC} = 3V$	$V_I = 0$	$I_O = 64\text{mA}$	—	5	7	
			$I_O = 24\text{mA}$	—	5	7	
		$V_I = 2.4V$	$I_O = 15\text{mA}$	—	10	15	

NOTES:

- Typical values are at $V_{CC} = 3.3V$, $+25^{\circ}\text{C}$ ambient.
- The increase in supply current is attributable to each current that is at the specified voltage level rather than V_{CC} or GND.
- This is measured by the voltage drop between the A and B terminals at the indicated current through the switch. On-state resistance is determined by the lower of the voltages of the two (A or B) terminals.

SWITCHING CHARACTERISTICS

Symbol	Parameter	$V_{CC} = 2.5V \pm 0.2V$		$V_{CC} = 3.3V \pm 0.3V$		Unit
		Min.	Max.	Min.	Max.	
$t_{PD}^{(1)}$	Propagation Delay A to B or B to A	—	0.15	—	0.25	ns
t_{SEL}	Select Time S to A or B	1	4.8	1	4.5	ns
t_{EN}	Enable Time S to B	1	4.8	1	4.5	ns
t_{DIS}	Disable Time S to B	1	5.1	1	5.3	ns
t_{EN}	Output Enable Time \overline{OE} to A or B	1	5	1	4.8	ns
t_{DIS}	Output Disable Time \overline{OE} to A or B	1	5.5	1	5.4	ns

- NOTE:
- The propagation delay is the calculated RC time constant of the typical on-state resistance of the switch and the specified load capacitance driven by an ideal voltage source (zero output impedance).

TEST CIRCUITS AND WAVEFORMS

TEST CONDITIONS

Symbol	$V_{CC}^{(1)}=3.3V\pm 0.3V$	$V_{CC}^{(2)}=2.5V\pm 0.2V$	Unit
V_{LOAD}	6	$2 \times V_{CC}$	V
V_{IH}	3	V_{CC}	V
V_T	1.5	$V_{CC} / 2$	V
V_{LZ}	300	150	mV
V_{HZ}	300	150	mV
C_L	50	30	pF

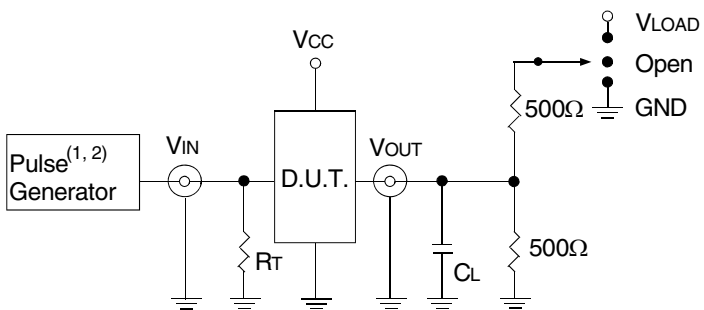

Test Circuits for All Outputs

DEFINITIONS:

C_L = Load capacitance: includes jig and probe capacitance.
 R_T = Termination resistance: should be equal to Z_{OUT} of the Pulse Generator.

NOTES:

1. Pulse Generator for All Pulses: Rate $\leq 10\text{MHz}$; $t_r \leq 2.5\text{ns}$; $t_f \leq 2.5\text{ns}$.
2. Pulse Generator for All Pulses: Rate $\leq 10\text{MHz}$; $t_r \leq 2\text{ns}$; $t_f \leq 2.5\text{ns}$.

SWITCH POSITION

Test	Switch
t_{PLZ}/t_{PZL}	V_{LOAD}
t_{PHZ}/t_{PZH}	GND
t_{SEL}	Open
t_{PD}	Open

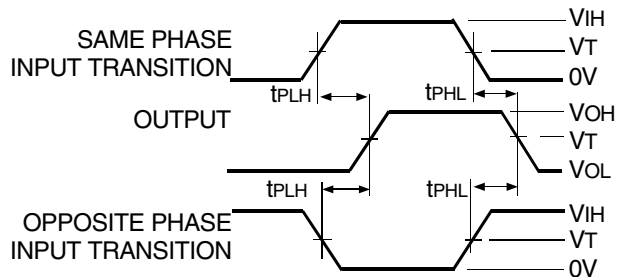

Propagation Delay

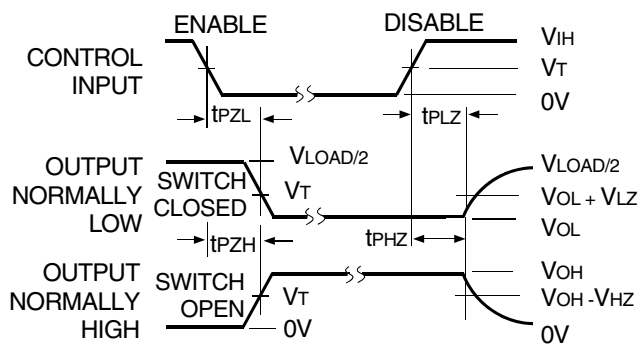

Enable and Disable Times

ORDERING INFORMATION

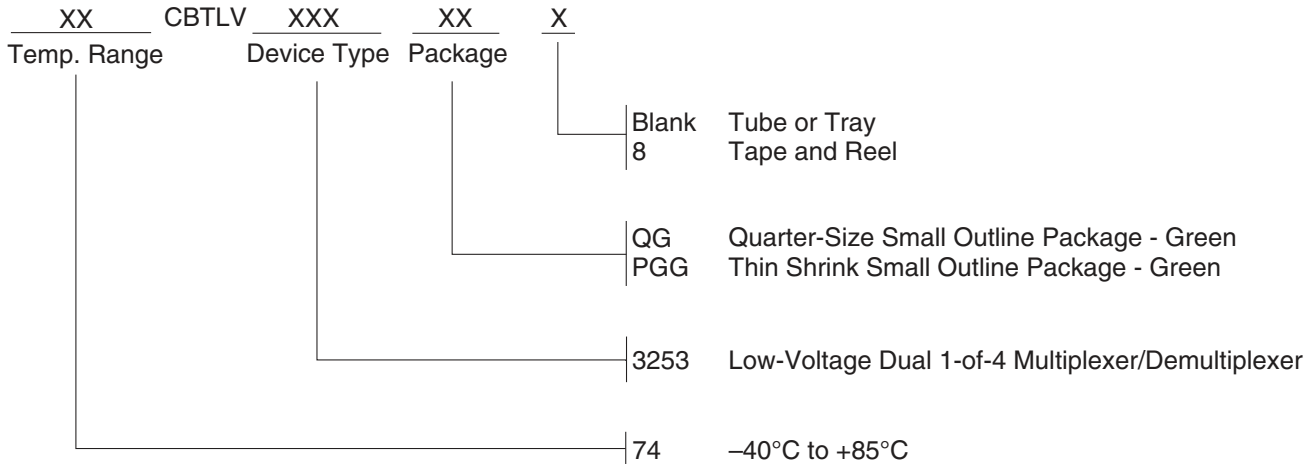

Datasheet Document History

12/18/2014 Pg. 5 Updated the ordering information by removing the "IDT" notation, non RoHS part and by adding Tape and Reel information.



CORPORATE HEADQUARTERS
6024 Silver Creek Valley Road
San Jose, CA 95138

for SALES:
800-345-7015 or 408-284-8200
fax: 408-284-2775
www.idt.com

for Tech Support:
logichelp@idt.com