

## TLC59210 8-BIT DMOS Sink Driver With Latch

### 1 Features

- DMOS Process
- High Voltage Output ( $V_{ds} = 30\text{ V}$ )
- Output Current on Each Channel ( $I_{ds}\text{ Max} = 200\text{ mA}$ )
- Latch-Up Performance Exceeds 250 mA Per JEDEC Standard JESD-17
- ESD Protection Exceeds JESD 22
  - 2000-V Human Body Model (A114-A)
  - 200-V Machine Model (A115-A)
  - 1000-V Charged Device Model (C101)
- LED Driver Application
- Output Clamp Diodes (Parasitic)
- Control Pins of  $\overline{\text{CLR}}$  and CLK Inputs
- Clock Input up to 1 MHz

### 2 Applications

- Lamp and Display (LED)
- Hammer
- Relay

### 3 Description

The TLC59210 is an 8-bit flip-flop driver for LED and solenoid with Schmitt-trigger buffers. Each channel can sink up to 200mA and support an output voltage up to 30V. The TLC59210 is designed for  $V_{CC}$  and operation from 3.3V to 5.5V.

Each output channel is controlled by a positive-edge-triggered D-type flip-flops with a direct clear (CLR) input. Information at the data (D) input meeting the setup time requirements is transferred to the Y output on the positive-going edge of the clock (CLK) pulse. Clock triggering occurs at a particular voltage level and is not directly related to the transition time of the positive-going pulse. When CLK is at either the high or low level, the D input has no effect at the output.

The TLC59210 is characterized for operation from  $-40^{\circ}\text{C}$  to  $85^{\circ}\text{C}$ .

#### Device Information<sup>(1)</sup>

| PART NUMBER | PACKAGE    | BODY SIZE (NOM)    |
|-------------|------------|--------------------|
| TLC59210    | PDIP (20)  | 24.33 mm × 6.35 mm |
|             | TSSOP (20) | 6.50 mm × 4.40 mm  |

(1) For all available packages, see the orderable addendum at the end of the data sheet.

#### Typical Application Schematic

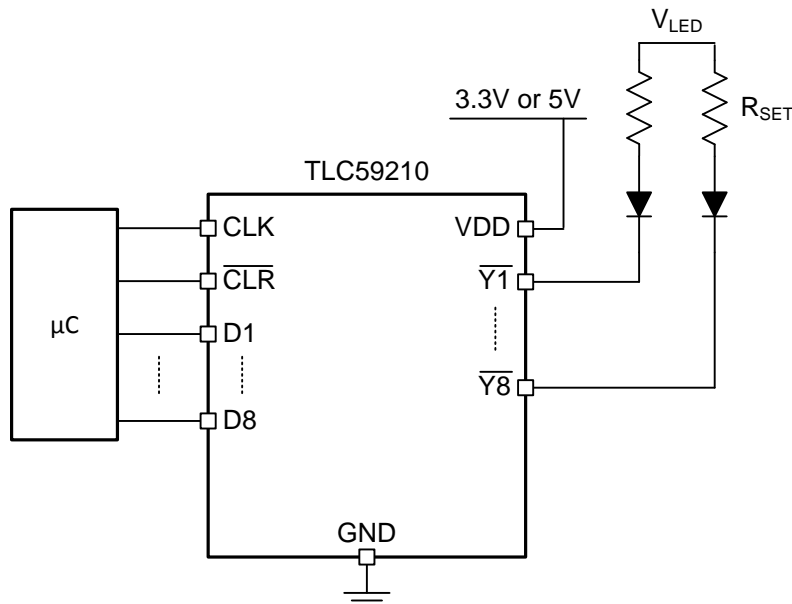

## Table of Contents

|          |   |          |           |   |           |
|----------|---|----------|-----------|---|-----------|
| <b>1</b> | <b>Features</b> .....   | <b>1</b> | <b>8</b>  | <b>Detailed Description</b> .....                             | <b>9</b>  |
| <b>2</b> | <b>Applications</b> .....   | <b>1</b> | 8.1       | Overview .....  | 9         |
| <b>3</b> | <b>Description</b> .....  | <b>1</b> | 8.2       | Functional Block Diagram .....                                | 9         |
| <b>4</b> | <b>Revision History</b> .....   | <b>2</b> | 8.3       | Feature Description .....                                     | 10        |
| <b>5</b> | <b>Pin Configuration and Functions</b> .....                              | <b>3</b> | 8.4       | Device Functional Modes .....                                 | 10        |
| <b>6</b> | <b>Specifications</b> .....   | <b>4</b> | <b>9</b>  | <b>Application and Implementation</b> .....                   | <b>11</b> |
| 6.1      | Absolute Maximum Ratings .....  | 4        | 9.1       | Application Information .....                                 | 11        |
| 6.2      | ESD Ratings .....   | 4        | 9.2       | Typical Application .....                                     | 11        |
| 6.3      | Recommended Operating Conditions .....                                    | 4        | <b>10</b> | <b>Power Supply Recommendations</b> .....                     | <b>13</b> |
| 6.4      | Thermal Information .....   | 4        | <b>11</b> | <b>Layout</b> .....   | <b>13</b> |
| 6.5      | Electrical Characteristics: $V_{CC} = 4.5\text{ V to }5.5\text{ V}$ ..... | 5        | 11.1      | Layout Guidelines .....                                       | 13        |
| 6.6      | Electrical Characteristics: $V_{CC} = 3\text{ V to }3.6\text{ V}$ .....   | 5        | 11.2      | Layout Example .....  | 13        |
| 6.7      | Timing Requirements: $V_{CC} = 4.5\text{ V to }5.5\text{ V}$ .....        | 6        | <b>12</b> | <b>Device and Documentation Support</b> .....                 | <b>14</b> |
| 6.8      | Timing Requirements: $V_{CC} = 3\text{ V to }3.6\text{ V}$ .....          | 6        | 12.1      | Community Resources .....                                     | 14        |
| 6.9      | Switching Characteristics: $V_{CC} = 4.5\text{ V to }5.5\text{ V}$ .....  | 6        | 12.2      | Trademarks .....  | 14        |
| 6.10     | Switching Characteristics: $V_{CC} = 3\text{ V to }3.6\text{ V}$ .....    | 6        | 12.3      | Electrostatic Discharge Caution .....                         | 14        |
| 6.11     | Typical Characteristics .....   | 7        | 12.4      | Glossary .....  | 14        |
| <b>7</b> | <b>Parameter Measurement Information</b> .....                            | <b>8</b> | <b>13</b> | <b>Mechanical, Packaging, and Orderable Information</b> ..... | <b>14</b> |

## 4 Revision History

### Changes from Original (March 2009) to Revision A

Page

- Added *Pin Configuration and Functions* section, *ESD Ratings* table, *Feature Description* section, *Device Functional Modes*, *Application and Implementation* section, *Power Supply Recommendations* section, *Layout* section, *Device and Documentation Support* section, and *Mechanical, Packaging, and Orderable Information* section ..... **1**

## 5 Pin Configuration and Functions

**N or PW Package  
20 Pin PDIP or TSSOP  
(Top View)**

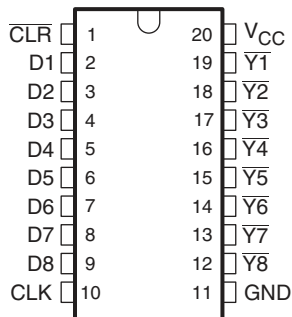

**Pin Functions**

| PIN |                 | I/O    | DESCRIPTION   |
|-----|-----------------|--------|---|
| NO. | NAME            |        |   |
| 1   | CLR             | I      | Direct Clear. When Low, all outputs are off   |
| 2   | D1              | I      | Data Input 1  |
| 3   | D2              | I      | Data Input 2  |
| 4   | D3              | I      | Data Input 3  |
| 5   | D4              | I      | Data Input 4  |
| 6   | D5              | I      | Data Input 5  |
| 7   | D6              | I      | Data Input 6  |
| 8   | D7              | I      | Data Input 7  |
| 9   | D8              | I      | Data Input 8  |
| 10  | CLK             | I      | Clock input. A Rising Edge transfers information at the data input (D) to the output (Y). |
| 11  | GND             | GND    | Ground  |
| 12  | Y8              | Output | Data Output 8   |
| 13  | Y7              | Output | Data Output 7   |
| 14  | Y6              | Output | Data Output 6   |
| 15  | Y5              | Output | Data Output 5   |
| 16  | Y4              | Output | Data Output 4   |
| 17  | Y3              | Output | Data Output 3   |
| 18  | Y2              | Output | Data Output 2   |
| 19  | Y1              | Output | Data Output 1   |
| 20  | V <sub>CC</sub> | Power  | Supply for Device   |

## 6 Specifications

### 6.1 Absolute Maximum Ratings

<sup>(1)</sup>over operating free-air temperature range (unless otherwise noted)

|                  |                                |                       | MIN                              | MAX | UNIT |
|------------------|--------------------------------|-----------------------|----------------------------------|-----|------|
| V <sub>CC</sub>  | Supply voltage                 |                       | -0.5                             | 7   | V    |
| D                | Input voltage                  |                       | -0.5                             | 7   | V    |
| V <sub>ds</sub>  | Output voltage                 | H output              | -0.5                             | 32  | V    |
| I <sub>ds</sub>  | Output current                 | 1 bit for output low, | V <sub>CC</sub> = 3 V to 3.6 V   | 100 | mA   |
|                  |                                |                       | V <sub>CC</sub> = 4.5 V to 5.5 V | 200 |      |
| I <sub>IK</sub>  | Input clamp current            | V <sub>I</sub> < 0 V  |                                  | -20 | mA   |
|                  | Operating free-air temperature |                       | -40                              | 85  | °C   |
| T <sub>stg</sub> | Storage temperature            |                       | -65                              | 150 | °C   |

(1) Stresses beyond those listed under "absolute maximum ratings" may cause permanent damage to the device. These are stress ratings only, and functional operation of the device at these or any other conditions beyond those indicated under "recommended operating conditions" is not implied. Exposure to absolute-maximum-rated conditions for extended periods may affect device reliability.

### 6.2 ESD Ratings

|                    |                         |  | VALUE | UNIT |
|--------------------|-------------------------|--|-------|------|
| V <sub>(ESD)</sub> | Electrostatic discharge | Human body model (HBM), per ANSI/ESDA/JEDEC JS-001 <sup>(1)</sup>              | ±2000 | V    |
|                    |                         | Charged-device model (CDM), per JEDEC specification JESD22-C101 <sup>(2)</sup> | ±1000 |      |
|                    |                         | Machine Model (A115-A), per ANSI/ESDA/JEDEC Standard JESD-17 <sup>(3)</sup>    | ±200  |      |

(1) JEDEC document JEP155 states that 500-V HBM allows safe manufacturing with a standard ESD control process.

(2) JEDEC document JEP157 states that 250-V CDM allows safe manufacturing with a standard ESD control process.

(3) JEDEC document JEP157 states that 200-V MM allows safe manufacturing with a standard ESD control process.

### 6.3 Recommended Operating Conditions

|                 |                                |   | MIN                   | MAX                   | UNIT |
|-----------------|--------------------------------|---|-----------------------|-----------------------|------|
| V <sub>CC</sub> | Supply voltage                 |   | 3                     | 5.5                   | V    |
| V <sub>IH</sub> | High-level input voltage       |   | V <sub>CC</sub> × 0.7 | V <sub>CC</sub>       | V    |
| V <sub>IL</sub> | Low-level input voltage        |   | 0                     | V <sub>CC</sub> × 0.3 | V    |
| V <sub>ds</sub> | Output voltage                 |   |                       | 30                    | V    |
| I <sub>ds</sub> | Output current                 | N package,<br>V <sub>CC</sub> = 4.5 V to 5.5 V  | Duty cycle < 42%      | 200                   | mA   |
|                 |                                |   | Duty cycle < 100%     | 130                   |      |
|                 |                                | PW package,<br>V <sub>CC</sub> = 4.5 V to 5.5 V | Duty cycle < 24%      | 200                   |      |
|                 |                                |   | Duty cycle < 100%     | 95                    |      |
| T <sub>A</sub>  | Operating free-air temperature |   | -40                   | 85                    | °C   |

### 6.4 Thermal Information

| THERMAL METRIC <sup>(1)</sup> |  | TLC59210 |            | UNIT |
|-------------------------------|--|----------|------------|------|
|                               |  | N (PDIP) | PW (TSSOP) |      |
|                               |  | 20 PINS  | 20 PINS    |      |
| R <sub>θJA</sub>              | Junction-to-ambient thermal resistance       | 53.6     | 94.3       | °C/W |
| R <sub>θJC(top)</sub>         | Junction-to-case (top) thermal resistance    | 41.2     | 28.3       | °C/W |
| R <sub>θJB</sub>              | Junction-to-board thermal resistance         | 34.6     | 45.7       | °C/W |
| Ψ <sub>JT</sub>               | Junction-to-top characterization parameter   | 22.3     | 1.6        | °C/W |
| Ψ <sub>JB</sub>               | Junction-to-board characterization parameter | 34.4     | 45.1       | °C/W |
| R <sub>θJC(bot)</sub>         | Junction-to-case (bottom) thermal resistance | N/A      | N/A        | °C/W |

(1) For more information about traditional and new thermal metrics, see the *Semiconductor and IC Package Thermal Metrics* application report, [SPRA953](#).

### 6.5 Electrical Characteristics: $V_{CC} = 4.5\text{ V to }5.5\text{ V}$

 over recommended operating free-air temperature range,  $T_A = -40^\circ\text{C to }85^\circ\text{C}$  (unless otherwise noted)

| PARAMETER |                                | TEST CONDITIONS   | MIN              | TYP | MAX  | UNIT          |               |
|-----------|--------------------------------|---|------------------|-----|------|---------------|---------------|
| $V_{T+}$  | Positive-going input threshold | D, $\overline{\text{CLR}}$ , CLK  |                  |     | 3.5  | V             |               |
| $V_{T-}$  | Negative-going input threshold | D, $\overline{\text{CLR}}$ , CLK  | 1.5              |     |      | V             |               |
| $V_{HYS}$ | Hysteresis                     | D, $\overline{\text{CLR}}$ , CLK  | 0.5              |     | 2    | V             |               |
| $I_{IH}$  | High-level input current       | $V_{CC} = 5.5\text{ V}$ , $V_I = 5.5\text{ V}$                                  |                  | 0   | 1    | $\mu\text{A}$ |               |
| $I_{IL}$  | Low-level input current        | $V_{CC} = 5.5\text{ V}$ , $V_I = 0\text{ V}$                                    |                  | 0   | -1   | $\mu\text{A}$ |               |
| $I_{OZ}$  | Leakage current                | $V_{ds} = 30\text{ V}$  |                  |     | 5    | $\mu\text{A}$ |               |
| $I_{off}$ | Leakage current                | $V_I = 0\text{ to }5\text{ V}$ , $V_O = 0\text{ to }30\text{ V}$ , $V_{CC} = 0$ |                  | 0   | 5    | $\mu\text{A}$ |               |
| $I_{CC}$  | Supply current                 | $V_I = 0\text{ to }5\text{ V}$ , $V_O = 0\text{ to }30\text{ V}$ , $V_{CC} = 0$ | Output = all OFF |     | 0    | 5             | $\mu\text{A}$ |
|           |                                |   | Output = all ON  |     | 0    | 5             |               |
| $V_{OL}$  | Low-level output voltage       | $V_{CC} = 4.5\text{ V}$ , $I_O = 100\text{ mA}$                                 |                  | 0.2 | 0.35 | V             |               |
|           |                                | $V_{CC} = 4.5\text{ V}$ , $I_O = 200\text{ mA}$                                 |                  | 0.5 | 0.7  | V             |               |
| $r_{ON}$  | ON-state resistance            | $V_{CC} = 4.5\text{ V}$ , $I_O = 100\text{ mA}$                                 |                  | 2   | 3.5  | $\Omega$      |               |
| $C_i$     | Input capacitance              | $V_I = V_{CC}$ or GND   |                  | 5   |      | pF            |               |

### 6.6 Electrical Characteristics: $V_{CC} = 3\text{ V to }3.6\text{ V}$

 over recommended operating free-air temperature range,  $T_A = -40^\circ\text{C to }85^\circ\text{C}$  (unless otherwise noted)

| PARAMETER |                                | TEST CONDITIONS  | MIN              | TYP  | MAX  | UNIT          |               |
|-----------|--------------------------------|--|------------------|------|------|---------------|---------------|
| $V_{T+}$  | Positive-going input threshold | D, $\overline{\text{CLR}}$ , CLK   |                  |      | 2.52 | V             |               |
| $V_{T-}$  | Negative-going input threshold | D, $\overline{\text{CLR}}$ , CLK   | 0.9              |      |      | V             |               |
| $V_{HYS}$ | Hysteresis                     | D, $\overline{\text{CLR}}$ , CLK   | 0.33             |      | 1.32 | V             |               |
| $I_{IH}$  | High-level input current       | $V_{CC} = 3.6\text{ V}$ , $V_I = 3.6\text{ V}$   |                  | 0    | 1    | $\mu\text{A}$ |               |
| $I_{IL}$  | Low-level input current        | $V_{CC} = 3.6\text{ V}$ , $V_I = 0\text{ V}$   |                  | 0    | -1   | $\mu\text{A}$ |               |
| $I_{OZ}$  | Leakage current                | $V_O = 30\text{ V}$  |                  |      | 5    | $\mu\text{A}$ |               |
| $I_{off}$ | Leakage current                | $V_{CC} = 0\text{ V}$ , $V_I = 0\text{ to }3.6\text{ V}$ , $V_O = 0\text{ to }30\text{ V}$ |                  | 0    | 5    | $\mu\text{A}$ |               |
| $I_{CC}$  | Supply current                 | $V_{CC} = 3.6\text{ V}$ , $V_I = 0\text{ to }3.6\text{ V}$ , $V_O = 0$<br>to $30\text{ V}$ | Output = all OFF |      | 0    | 5             | $\mu\text{A}$ |
|           |                                |  | Output = all ON  |      | 0    | 5             |               |
| $V_{OL}$  | Low-level output voltage       | $V_{CC} = 3\text{ V}$ , $I_O = 100\text{ mA}$  |                  | 0.35 | 0.7  | V             |               |
| $r_{ON}$  | ON-state resistance            | $V_{CC} = 3\text{ V}$ , $I_O = 100\text{ mA}$  |                  | 3.5  | 7    | $\Omega$      |               |
| $C_i$     | Input capacitance              | $V_I = V_{CC}$ or GND  |                  | 5    |      | pF            |               |

### 6.7 Timing Requirements: $V_{CC} = 4.5\text{ V to }5.5\text{ V}$

over recommended operating free-air temperature range, O/C to Y (unless otherwise noted)

|          |   |                         | MIN | NOM | MAX | UNIT |
|----------|---|-------------------------|-----|-----|-----|------|
| $t_{su}$ | Setup time, CLK $\uparrow$                | $V_{DD} = 4.5\text{ V}$ | 10  |     |     | ns   |
| $t_h$    | Hold time, CLK $\uparrow$                 | $V_{DD} = 4.5\text{ V}$ | 10  |     |     | ns   |
| $t_w$    | Pulse width, CLK, $\overline{\text{CLR}}$ | $V_{DD} = 4.5\text{ V}$ | 30  |     |     | ns   |

### 6.8 Timing Requirements: $V_{CC} = 3\text{ V to }3.6\text{ V}$

over recommended operating free-air temperature range, O/C to Y (unless otherwise noted)

|          |   |                       | MIN | NOM | MAX | UNIT |
|----------|---|-----------------------|-----|-----|-----|------|
| $t_{su}$ | Setup time, CLK $\uparrow$                | $V_{DD} = 3\text{ V}$ | 10  |     |     | ns   |
| $t_h$    | Hold time, CLK $\uparrow$                 | $V_{DD} = 3\text{ V}$ | 10  |     |     | ns   |
| $t_w$    | Pulse width, CLK, $\overline{\text{CLR}}$ | $V_{DD} = 3\text{ V}$ | 30  |     |     | ns   |

### 6.9 Switching Characteristics: $V_{CC} = 4.5\text{ V to }5.5\text{ V}$

 over recommended operating free-air temperature range,  $T_A = -40^\circ\text{C to }85^\circ\text{C}$  (unless otherwise noted), see [Figure 5](#)

| PARAMETER  | TEST CONDITIONS                              |   | LOAD CAPACITANCE  | MIN | TYP | MAX | UNIT |
|------------|--|---|---|-----|-----|-----|------|
| $t_{TLH}$  | Output = low to high                         | $T_A = 25^\circ\text{C}$                      | $C_L = 30\text{ pF}$ , $R_L = 240\ \Omega$ ,<br>24-V pullup |     | 180 | 230 | ns   |
|            |  | $T_A = -40^\circ\text{C to }85^\circ\text{C}$ |   |     |     | 260 |      |
| $t_{THL}$  | Output = high to low                         | $T_A = 25^\circ\text{C}$                      | $C_L = 30\text{ pF}$ , $R_L = 240\ \Omega$ ,<br>24-V pullup |     | 300 | 450 | ns   |
|            |  | $T_A = -40^\circ\text{C to }85^\circ\text{C}$ |   |     |     | 500 |      |
| $t_{PLH}$  | Output = low to high                         | $T_A = 25^\circ\text{C}$                      | $C_L = 30\text{ pF}$ , $R_L = 240\ \Omega$ ,<br>24-V pullup |     | 320 | 480 | ns   |
|            |  | $T_A = -40^\circ\text{C to }85^\circ\text{C}$ |   |     |     | 550 |      |
| $t_{PHL}$  | Output = high to low                         | $T_A = 25^\circ\text{C}$                      | $C_L = 30\text{ pF}$ , $R_L = 240\ \Omega$ ,<br>24-V pullup |     | 320 | 480 | ns   |
|            |  | $T_A = -40^\circ\text{C to }85^\circ\text{C}$ |   |     |     | 550 |      |
| $t_{PHLR}$ | $\overline{\text{CLR}}\text{--}\overline{Y}$ | $T_A = 25^\circ\text{C}$                      | $C_L = 30\text{ pF}$ , $R_L = 240\ \Omega$ ,<br>24-V pullup |     | 320 | 480 | ns   |
|            |  | $T_A = -40^\circ\text{C to }85^\circ\text{C}$ |   |     |     | 550 |      |

### 6.10 Switching Characteristics: $V_{CC} = 3\text{ V to }3.6\text{ V}$

 over recommended operating free-air temperature range,  $T_A = -40^\circ\text{C to }85^\circ\text{C}$  (unless otherwise noted), see [Figure 5](#)

| PARAMETER  | TEST CONDITIONS                              |   | LOAD CAPACITANCE  | MIN | TYP | MAX | UNIT |
|------------|--|---|---|-----|-----|-----|------|
| $t_{TLH}$  | Output = low to high                         | $T_A = 25^\circ\text{C}$                      | $C_L = 30\text{ pF}$ , $R_L = 240\ \Omega$ ,<br>24-V pullup |     | 300 | 450 | ns   |
|            |  | $T_A = -40^\circ\text{C to }85^\circ\text{C}$ |   |     |     | 500 |      |
| $t_{THL}$  | Output = high to low                         | $T_A = 25^\circ\text{C}$                      | $C_L = 30\text{ pF}$ , $R_L = 240\ \Omega$ ,<br>24-V pullup |     | 300 | 450 | ns   |
|            |  | $T_A = -40^\circ\text{C to }85^\circ\text{C}$ |   |     |     | 500 |      |
| $t_{PLH}$  | Output = low to high                         | $T_A = 25^\circ\text{C}$                      | $C_L = 30\text{ pF}$ , $R_L = 240\ \Omega$ ,<br>24-V pullup |     | 500 | 700 | ns   |
|            |  | $T_A = -40^\circ\text{C to }85^\circ\text{C}$ |   |     |     | 850 |      |
| $t_{PHL}$  | Output = high to low                         | $T_A = 25^\circ\text{C}$                      | $C_L = 30\text{ pF}$ , $R_L = 240\ \Omega$ ,<br>24-V pullup |     | 500 | 700 | ns   |
|            |  | $T_A = -40^\circ\text{C to }85^\circ\text{C}$ |   |     |     | 850 |      |
| $t_{PHLR}$ | $\overline{\text{CLR}}\text{--}\overline{Y}$ | $T_A = 25^\circ\text{C}$                      | $C_L = 30\text{ pF}$ , $R_L = 240\ \Omega$ ,<br>24-V pullup |     | 500 | 700 | ns   |
|            |  | $T_A = -40^\circ\text{C to }85^\circ\text{C}$ |   |     |     | 850 |      |

### 6.11 Typical Characteristics

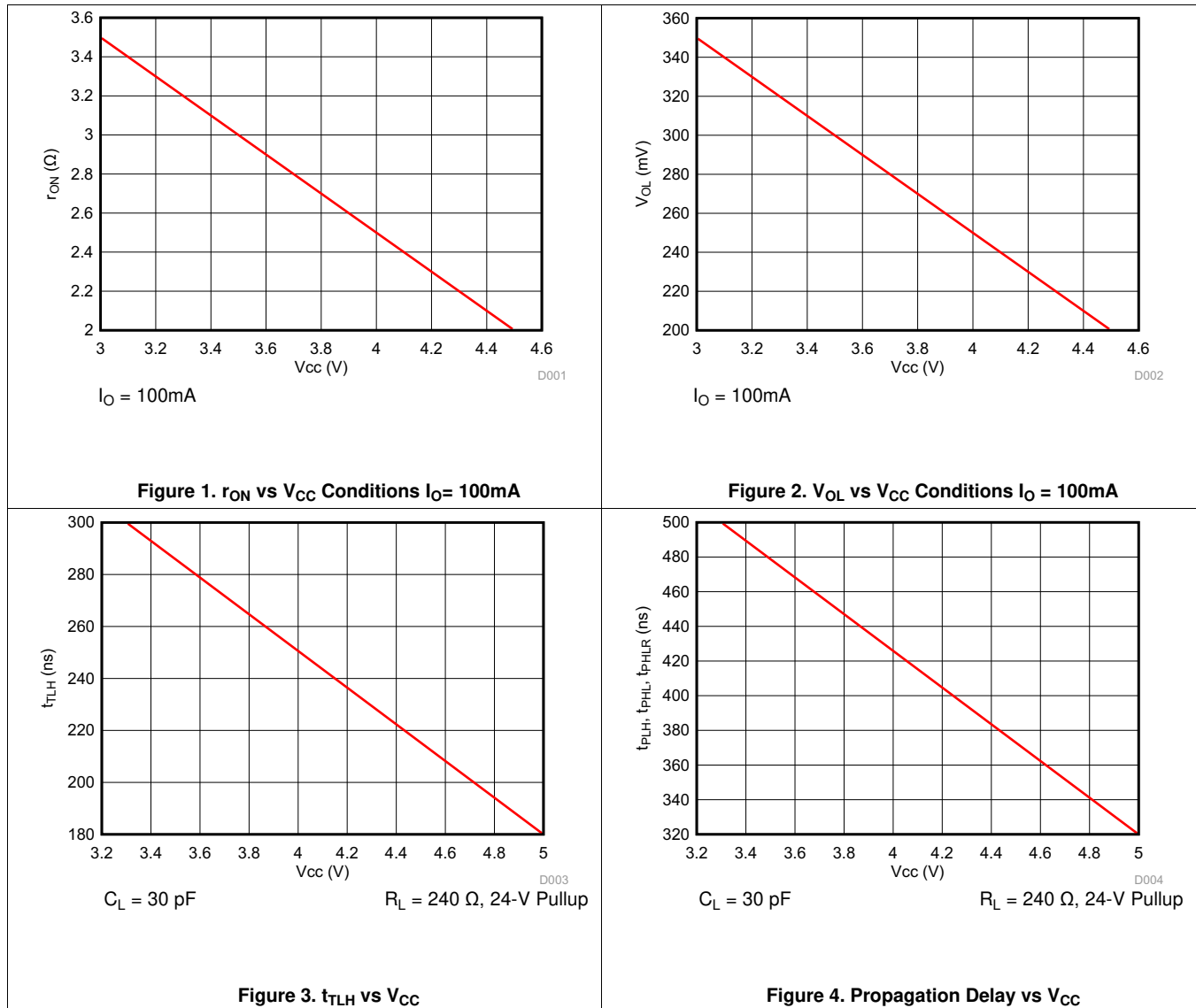

## 7 Parameter Measurement Information

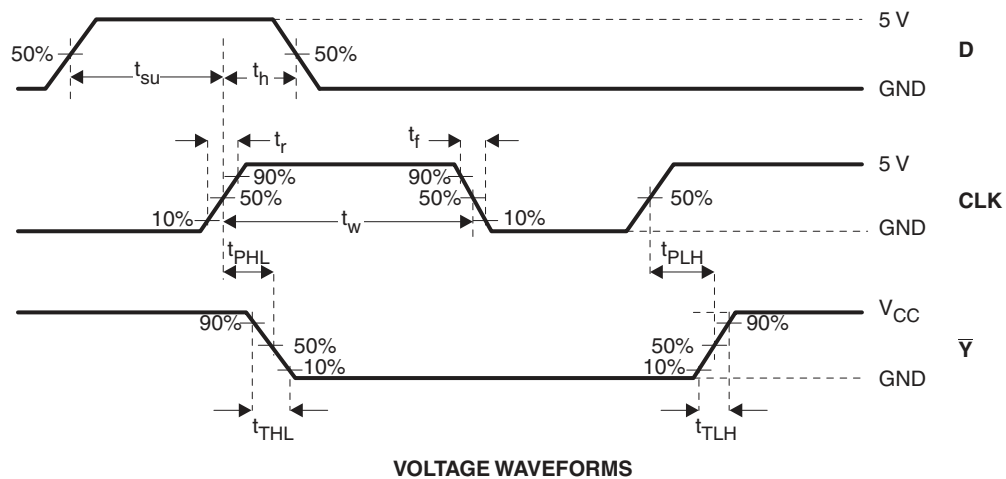
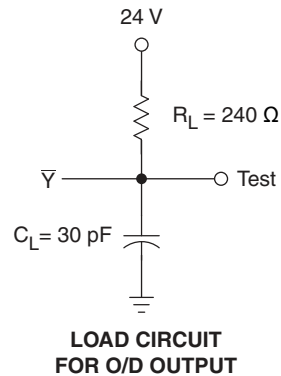

- A.  $C_L$  includes probe and jig capacitance.
- B. Waveform 1 is for an output with internal conditions such that the output is low except when disabled by the output control. Waveform 2 is for an output with internal conditions such that the output is high except when disabled by the output control.
- C. All input pulses are supplied by generators having the following characteristics:  $PRR \leq 1$  MHz,  $Z_O = 50 \Omega$ ,  $t_r \leq 3$  ns, and  $t_f \leq 3$  ns.
- D. The outputs are measured one at a time with one transition per measurement.
- E.  $t_{PLH}$  and  $t_{PHL}$  are the same as  $t_{pd}$ .

**Figure 5. Test Circuit and Voltage Waveforms**



## 8 Detailed Description

### 8.1 Overview

The TLC59210 is an 8-bit flip-flop driver for LED and solenoid with Schmitt-trigger buffers. Each output channel is controlled by a positive-edge-triggered D-type flip-flops with a direct clear (CLR) input. Information at the data (D) input meeting the setup time requirements is transferred to the Y output on the positive-going edge of the clock (CLK) pulse. Clock triggering occurs at a particular voltage level and is not directly related to the transition time of the positive-going pulse. When CLK is at either the high or low level, the D input has no effect at the output.

### 8.2 Functional Block Diagram

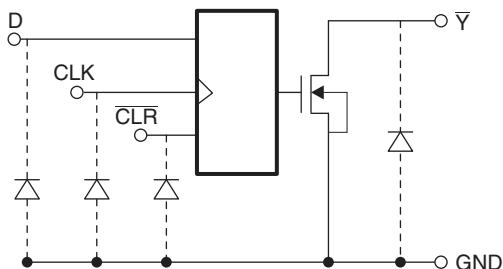
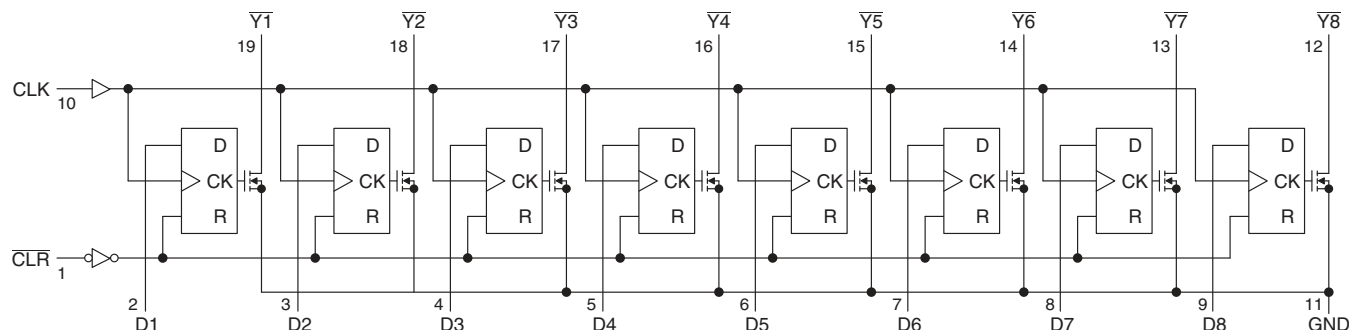

Figure 6. Output Schematic



This symbol is in accordance with ANSI/IEEE Standard 91-1984 and IEC Publication 617-12.

Figure 7. Logic Symbol

### 8.3 Feature Description

The TLC59210 features the ability to independently control 8 Sinking Outputs (Y). At each CLK pulse the output can be latched high or low depending on the input state (D). The CLR function allows for all outputs to be set high.

### 8.4 Device Functional Modes

**Table 1. Function Table  
(Each Latch)<sup>(1)</sup>**

| INPUTS |     |   | OUTPUT<br>Y    |
|--------|-----|---|----------------|
| CLR    | CLK | D |                |
| L      | X   | X | H*             |
| H      | ↑   | L | H*             |
| H      | ↑   | H | L              |
| H      | L   | X | Y <sub>0</sub> |
| H      | ↓   | X | Y <sub>0</sub> |

- (1) L: Low-level, H: High-level, H\*: with pullup resistor, X: Irrelevant, ↑: Rising edge, ↓: Falling edge, Z: High-impedance (OFF)

## 9 Application and Implementation

### NOTE

Information in the following applications sections is not part of the TI component specification, and TI does not warrant its accuracy or completeness. TI's customers are responsible for determining suitability of components for their purposes. Customers should validate and test their design implementation to confirm system functionality.

### 9.1 Application Information

In an LED display application, TLC59210 is used to drive the current sink for 8 LEDs in parallel. LED display patterns can be created by providing different bit patterns. Each LED can be duty cycled by either duty cycling the LED supply or the control bit.

#### 9.1.1 Setting LED Current

The LED current is primarily dependent on the supply voltage, the forward voltage of the LED, and the series resistor (RSET). In many applications the supply voltage and LED forward voltage cannot be adjusted. Hence, RSET is utilized to adjust the LED current.

#### 9.1.2 PWM Brightness Dimming

The perceived brightness of the LEDs can be adjusted by use of PWM dimming. For example, an LED driven at 50% duty cycle will appear less bright than it would at 100% duty cycle.

### 9.2 Typical Application

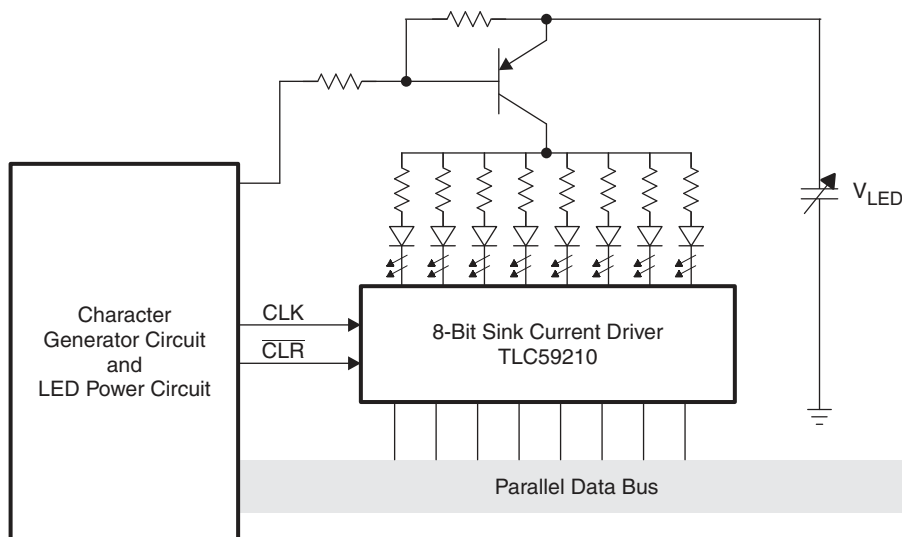

Figure 8. Typical Application Schematic

#### 9.2.1 Design Requirements

For an LED display application, a parallel data bus used to provide the input control for TLC59210. A character generator circuit and LED power circuit are used to generate the bit pattern written into the TLC59210 to provide the power control for the entire LED array. The LED power circuit controls the total current into the array and can also power cycle the LED array. For simple implementation, LED power circuit could be eliminated. The  $V_{LED}$  can be connected directly to the resistor and LED string.

## Typical Application (continued)

### 9.2.2 Detailed Design Procedure

The combination of LED Supply voltage ( $V_{LED}$ ), the LED forward voltage ( $V_F$ ), and external resistor sets the maximum LED current ( $I_{DS}$ ) that would appear with a 100% duty cycle.

$$I_{DS} = (V_{LED} - V_F) / R_{SET} \tag{1}$$

The maximum total power dissipation and maximum current through each channel of TLC59210 is determined by the number of the LEDs that are on at one time, the LED duty cycle, and the ambient temperature. The following graphs show how the maximum channel current may be limited by the total power dissipation.

### 9.2.3 Application Curves

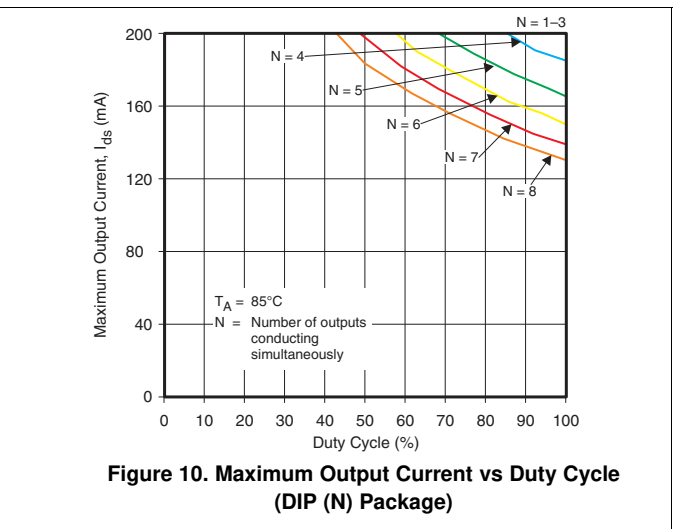
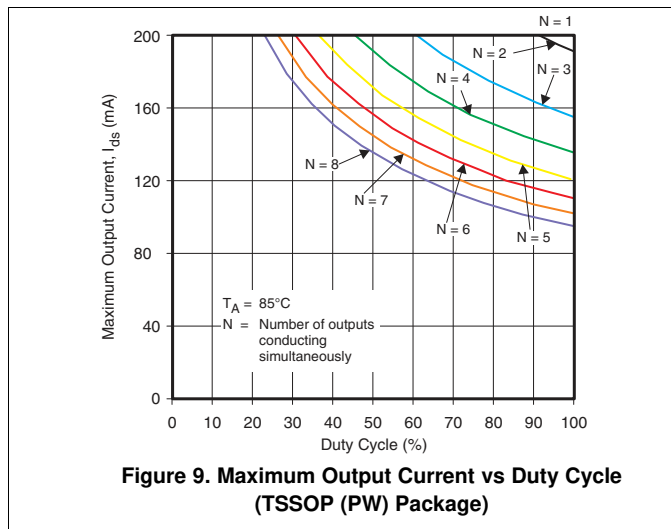

## 10 Power Supply Recommendations

TLC59210 operates from a VCC range of 3 V to 5.5 V. The system will also require a power supply for the LEDs. The supply voltage of the LEDs must be greater than the forward voltage of the LED plus the VOL of the channel, but not greater than 30V.

## 11 Layout

### 11.1 Layout Guidelines

The traces carrying power through the LEDs should be wide enough to handle the necessary current. All LED current passes through the device and into the ground node. There must be a strong connection between the device ground and the circuit board ground.

### 11.2 Layout Example

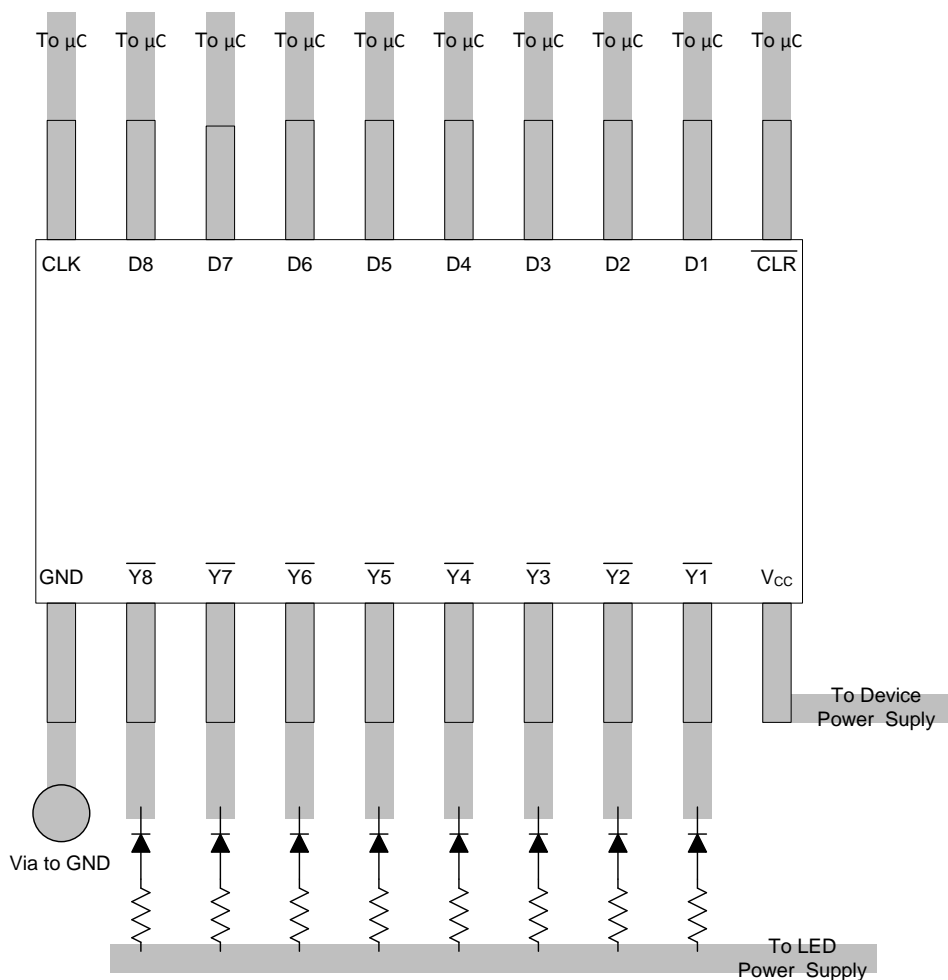

Figure 11. Layout Example

## 12 Device and Documentation Support

### 12.1 Community Resources

The following links connect to TI community resources. Linked contents are provided "AS IS" by the respective contributors. They do not constitute TI specifications and do not necessarily reflect TI's views; see TI's [Terms of Use](#).

**TI E2E™ Online Community** *TI's Engineer-to-Engineer (E2E) Community*. Created to foster collaboration among engineers. At [e2e.ti.com](http://e2e.ti.com), you can ask questions, share knowledge, explore ideas and help solve problems with fellow engineers.

**Design Support** *TI's Design Support* Quickly find helpful E2E forums along with design support tools and contact information for technical support.

### 12.2 Trademarks

E2E is a trademark of Texas Instruments.  
All other trademarks are the property of their respective owners.

### 12.3 Electrostatic Discharge Caution



These devices have limited built-in ESD protection. The leads should be shorted together or the device placed in conductive foam during storage or handling to prevent electrostatic damage to the MOS gates.

### 12.4 Glossary

[SLYZ022](#) — *TI Glossary*.

This glossary lists and explains terms, acronyms, and definitions.

## 13 Mechanical, Packaging, and Orderable Information

The following pages include mechanical, packaging, and orderable information. This information is the most current data available for the designated devices. This data is subject to change without notice and revision of this document. For browser-based versions of this data sheet, refer to the left-hand navigation.

**PACKAGING INFORMATION**

| Orderable Device | Status<br>(1) | Package Type | Package Drawing | Pins | Package Qty | Eco Plan<br>(2) | Lead finish/<br>Ball material<br>(6) | MSL Peak Temp<br>(3) | Op Temp (°C) | Device Marking<br>(4/5) | Samples                 |
|------------------|---------------|--------------|-----------------|------|-------------|-----------------|--------------------------------------|----------------------|--------------|-------------------------|-------------------------|
| TLC59210IN       | ACTIVE        | PDIP         | N               | 20   | 20          | RoHS & Green    | NIPDAU                               | N / A for Pkg Type   | -40 to 85    | TLC59210IN              | <a href="#">Samples</a> |
| TLC59210IPWR     | ACTIVE        | TSSOP        | PW              | 20   | 2000        | RoHS & Green    | NIPDAU                               | Level-1-260C-UNLIM   |              | Y59210                  | <a href="#">Samples</a> |

(1) The marketing status values are defined as follows:

**ACTIVE:** Product device recommended for new designs.

**LIFEBUY:** TI has announced that the device will be discontinued, and a lifetime-buy period is in effect.

**NRND:** Not recommended for new designs. Device is in production to support existing customers, but TI does not recommend using this part in a new design.

**PREVIEW:** Device has been announced but is not in production. Samples may or may not be available.

**OBSOLETE:** TI has discontinued the production of the device.

(2) **RoHS:** TI defines "RoHS" to mean semiconductor products that are compliant with the current EU RoHS requirements for all 10 RoHS substances, including the requirement that RoHS substance do not exceed 0.1% by weight in homogeneous materials. Where designed to be soldered at high temperatures, "RoHS" products are suitable for use in specified lead-free processes. TI may reference these types of products as "Pb-Free".

**RoHS Exempt:** TI defines "RoHS Exempt" to mean products that contain lead but are compliant with EU RoHS pursuant to a specific EU RoHS exemption.

**Green:** TI defines "Green" to mean the content of Chlorine (Cl) and Bromine (Br) based flame retardants meet JS709B low halogen requirements of <=1000ppm threshold. Antimony trioxide based flame retardants must also meet the <=1000ppm threshold requirement.

(3) MSL, Peak Temp. - The Moisture Sensitivity Level rating according to the JEDEC industry standard classifications, and peak solder temperature.

(4) There may be additional marking, which relates to the logo, the lot trace code information, or the environmental category on the device.

(5) Multiple Device Markings will be inside parentheses. Only one Device Marking contained in parentheses and separated by a "~" will appear on a device. If a line is indented then it is a continuation of the previous line and the two combined represent the entire Device Marking for that device.

(6) Lead finish/Ball material - Orderable Devices may have multiple material finish options. Finish options are separated by a vertical ruled line. Lead finish/Ball material values may wrap to two lines if the finish value exceeds the maximum column width.

**Important Information and Disclaimer:**The information provided on this page represents TI's knowledge and belief as of the date that it is provided. TI bases its knowledge and belief on information provided by third parties, and makes no representation or warranty as to the accuracy of such information. Efforts are underway to better integrate information from third parties. TI has taken and continues to take reasonable steps to provide representative and accurate information but may not have conducted destructive testing or chemical analysis on incoming materials and chemicals. TI and TI suppliers consider certain information to be proprietary, and thus CAS numbers and other limited information may not be available for release.

In no event shall TI's liability arising out of such information exceed the total purchase price of the TI part(s) at issue in this document sold by TI to Customer on an annual basis.





**TAPE AND REEL INFORMATION**

**QUADRANT ASSIGNMENTS FOR PIN 1 ORIENTATION IN TAPE**

\*All dimensions are nominal

| Device       | Package Type | Package Drawing | Pins | SPQ  | Reel Diameter (mm) | Reel Width W1 (mm) | A0 (mm) | B0 (mm) | K0 (mm) | P1 (mm) | W (mm) | Pin1 Quadrant |
|--------------|--------------|-----------------|------|------|--------------------|--------------------|---------|---------|---------|---------|--------|---------------|
| TLC59210IPWR | TSSOP        | PW              | 20   | 2000 | 330.0              | 16.4               | 6.95    | 7.0     | 1.4     | 8.0     | 16.0   | Q1            |

**TAPE AND REEL BOX DIMENSIONS**



\*All dimensions are nominal

| Device       | Package Type | Package Drawing | Pins | SPQ  | Length (mm) | Width (mm) | Height (mm) |
|--------------|--------------|-----------------|------|------|-------------|------------|-------------|
| TLC59210IPWR | TSSOP        | PW              | 20   | 2000 | 356.0       | 356.0      | 35.0        |

**TUBE**

\*All dimensions are nominal

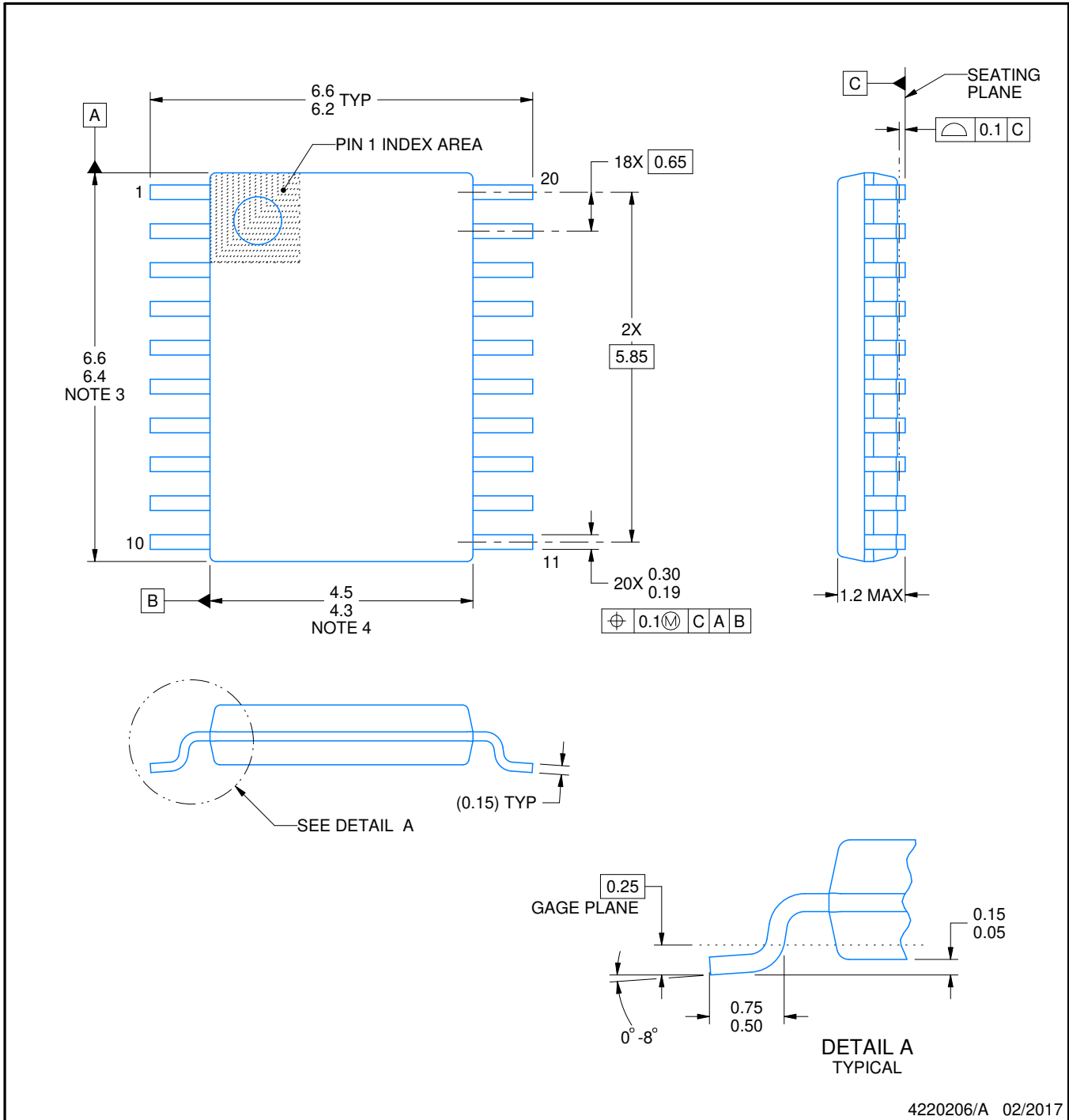
| Device     | Package Name | Package Type | Pins | SPQ | L (mm) | W (mm) | T (μm) | B (mm) |
|------------|--------------|--------------|------|-----|--------|--------|--------|--------|
| TLC59210IN | N            | PDIP         | 20   | 20  | 506    | 13.97  | 11230  | 4.32   |



4220206/A 02/2017

NOTES:

1. All linear dimensions are in millimeters. Any dimensions in parenthesis are for reference only. Dimensioning and tolerancing per ASME Y14.5M.
2. This drawing is subject to change without notice.
3. This dimension does not include mold flash, protrusions, or gate burrs. Mold flash, protrusions, or gate burrs shall not exceed 0.15 mm per side.
4. This dimension does not include interlead flash. Interlead flash shall not exceed 0.25 mm per side.
5. Reference JEDEC registration MO-153.

# EXAMPLE BOARD LAYOUT

PW0020A

TSSOP - 1.2 mm max height

SMALL OUTLINE PACKAGE

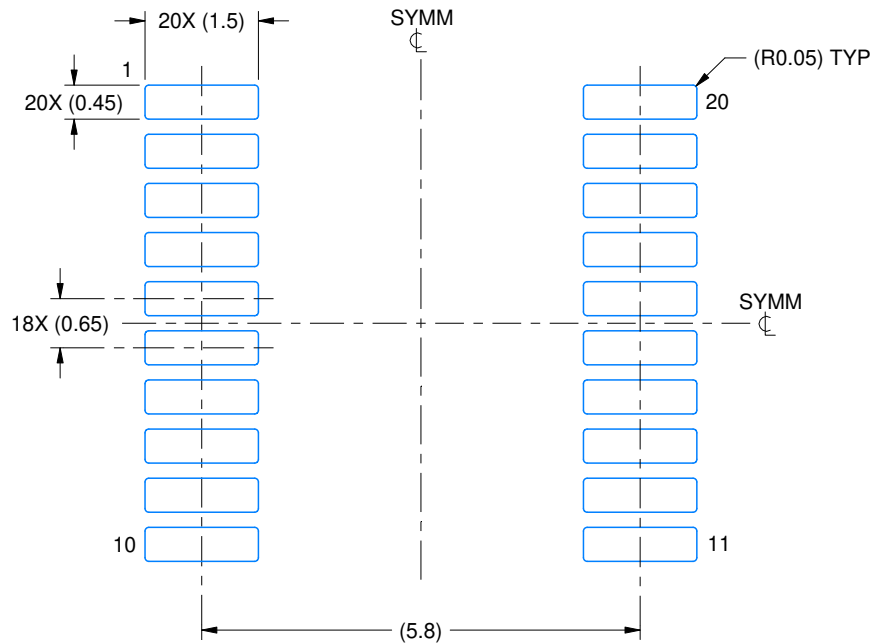

LAND PATTERN EXAMPLE  
EXPOSED METAL SHOWN  
SCALE: 10X

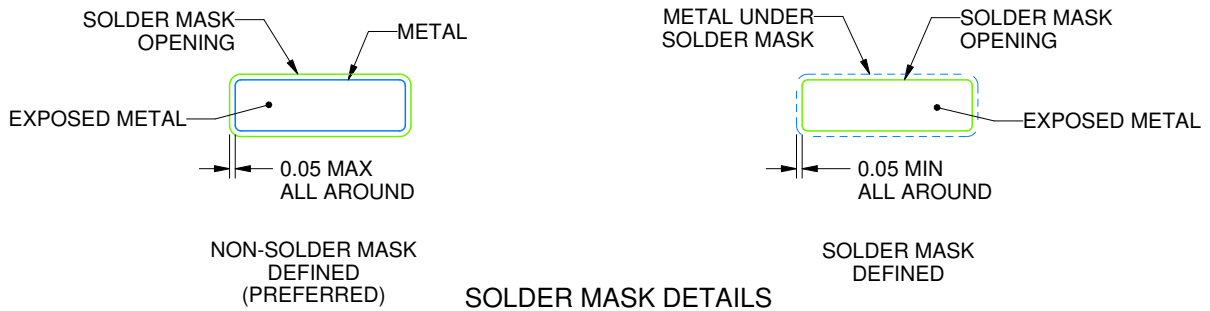

SOLDER MASK DETAILS

4220206/A 02/2017

NOTES: (continued)

- 6. Publication IPC-7351 may have alternate designs.
- 7. Solder mask tolerances between and around signal pads can vary based on board fabrication site.

# EXAMPLE STENCIL DESIGN

PW0020A

TSSOP - 1.2 mm max height

SMALL OUTLINE PACKAGE



SOLDER PASTE EXAMPLE  
BASED ON 0.125 mm THICK STENCIL  
SCALE: 10X

4220206/A 02/2017

NOTES: (continued)

8. Laser cutting apertures with trapezoidal walls and rounded corners may offer better paste release. IPC-7525 may have alternate design recommendations.
9. Board assembly site may have different recommendations for stencil design.

PW (R-PDSO-G20)

PLASTIC SMALL OUTLINE



- NOTES:
- A. All linear dimensions are in millimeters.
  - B. This drawing is subject to change without notice.
  - C. Publication IPC-7351 is recommended for alternate design.
  - D. Laser cutting apertures with trapezoidal walls and also rounding corners will offer better paste release. Customers should contact their board assembly site for stencil design recommendations. Refer to IPC-7525 for other stencil recommendations.
  - E. Customers should contact their board fabrication site for solder mask tolerances between and around signal pads.

N (R-PDIP-T\*\*)

PLASTIC DUAL-IN-LINE PACKAGE

16 PINS SHOWN



4040049/E 12/2002

- NOTES:
- A. All linear dimensions are in inches (millimeters).
  - B. This drawing is subject to change without notice.
  - C Falls within JEDEC MS-001, except 18 and 20 pin minimum body length (Dim A).
  - D The 20 pin end lead shoulder width is a vendor option, either half or full width.



## IMPORTANT NOTICE AND DISCLAIMER

TI PROVIDES TECHNICAL AND RELIABILITY DATA (INCLUDING DATA SHEETS), DESIGN RESOURCES (INCLUDING REFERENCE DESIGNS), APPLICATION OR OTHER DESIGN ADVICE, WEB TOOLS, SAFETY INFORMATION, AND OTHER RESOURCES "AS IS" AND WITH ALL FAULTS, AND DISCLAIMS ALL WARRANTIES, EXPRESS AND IMPLIED, INCLUDING WITHOUT LIMITATION ANY IMPLIED WARRANTIES OF MERCHANTABILITY, FITNESS FOR A PARTICULAR PURPOSE OR NON-INFRINGEMENT OF THIRD PARTY INTELLECTUAL PROPERTY RIGHTS.

These resources are intended for skilled developers designing with TI products. You are solely responsible for (1) selecting the appropriate TI products for your application, (2) designing, validating and testing your application, and (3) ensuring your application meets applicable standards, and any other safety, security, regulatory or other requirements.

These resources are subject to change without notice. TI grants you permission to use these resources only for development of an application that uses the TI products described in the resource. Other reproduction and display of these resources is prohibited. No license is granted to any other TI intellectual property right or to any third party intellectual property right. TI disclaims responsibility for, and you will fully indemnify TI and its representatives against, any claims, damages, costs, losses, and liabilities arising out of your use of these resources.

TI's products are provided subject to [TI's Terms of Sale](#) or other applicable terms available either on [ti.com](#) or provided in conjunction with such TI products. TI's provision of these resources does not expand or otherwise alter TI's applicable warranties or warranty disclaimers for TI products.

TI objects to and rejects any additional or different terms you may have proposed.

Mailing Address: Texas Instruments, Post Office Box 655303, Dallas, Texas 75265  
Copyright © 2023, Texas Instruments Incorporated