

NHD-C12864M1R-FSW-FTW-3V6

COG (Chip-On-Glass) Liquid Crystal Display Module

NHD-	Newhaven Display
C12864-	128 x 64 pixels
M1R-	Model
F-	Transflective
SW-	Side White LED Backlight
F-	FSTN (+)
T-	12:00 Optimal View
W-	Wide Temperature
3V6-	3.3V LCD, 6.0V Backlight
	RoHS Compliant

Newhaven Display International, Inc.

2661 Galvin Dr.

Elgin IL, 60124

Ph: 847-844-8795

Fax: 847-844-8796

www.newhavendisplay.com

nhtech@newhavendisplay.com

nhsales@newhavendisplay.com

Document Revision History

Revision	Date	Description	Changed by
0	5/6/2009	Initial Release	-
1	10/13/2009	User guide reformat	MC
2	11/20/2009	Updated backlight supply current	MC
3	6/22/2010	Updated drawing to include Backlight Adhesive	CL
4	2/3/2011	Updated drawing with pin numbers	AK
5	2/13/2011	Change controller to ST7565R	CL
6	3/28/2011	Controller information updated	AK
7	1/20/2014	Mechanical drawing, Electrical characteristics updated	AK
8	10/9/18	Backlight Drive Method Updated	SB

Functions and Features

- 128 x 64 pixels
- 8080 or 6800 MPU interface
- Built-in ST7565R controller
- +3.3V power supply
- 1/64 duty cycle; 1/9 bias
- RoHS Compliant
- 3M 9080 adhesive on backlight assembly

<http://multimedia.3m.com/mws/mediawebserver?66666UuZjcFSLXTt4XfEnxfyEVuQEcuZgVs6EVs6E666666-->

SYMBOL	REVISION	DATE

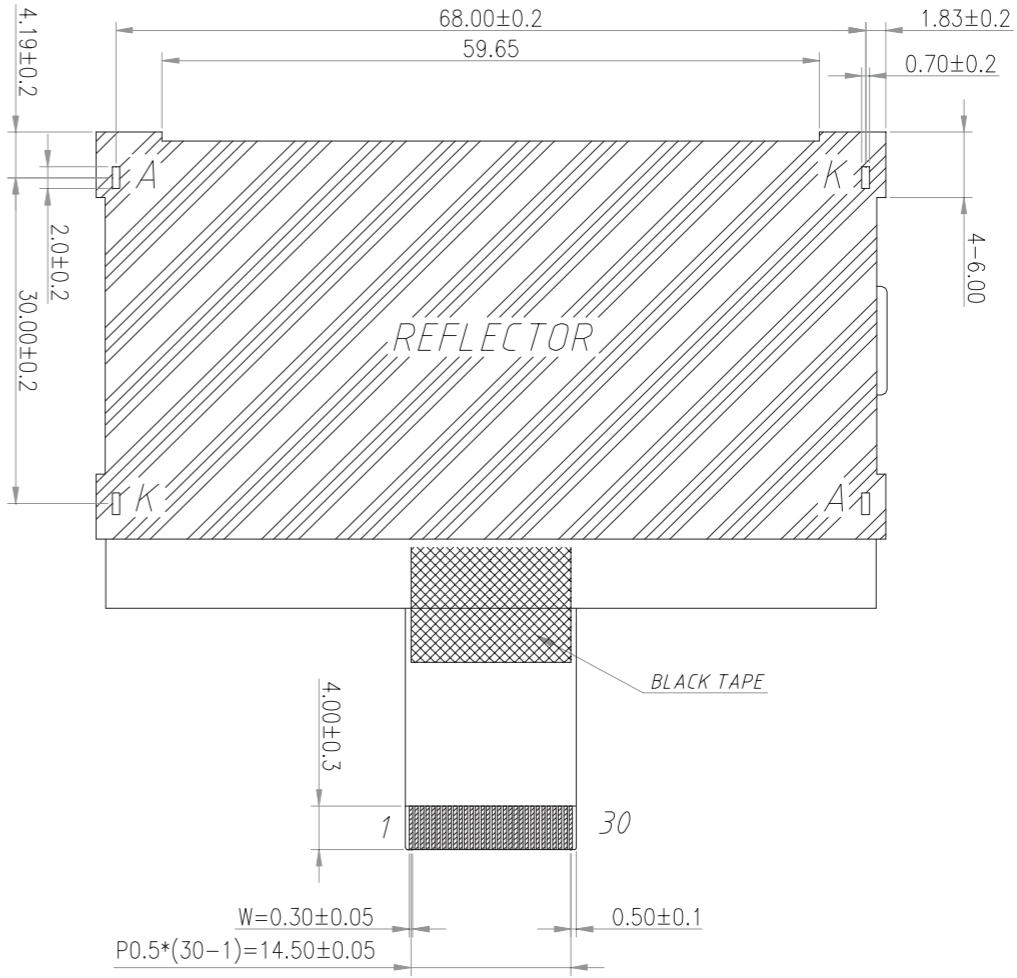
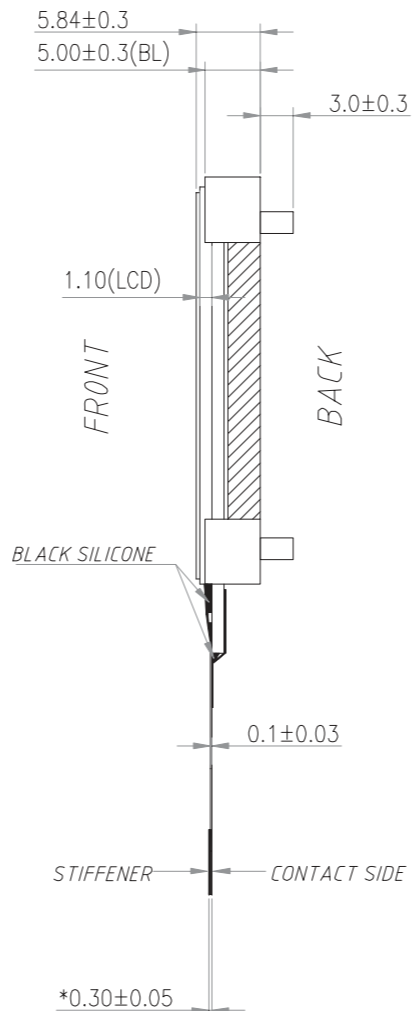
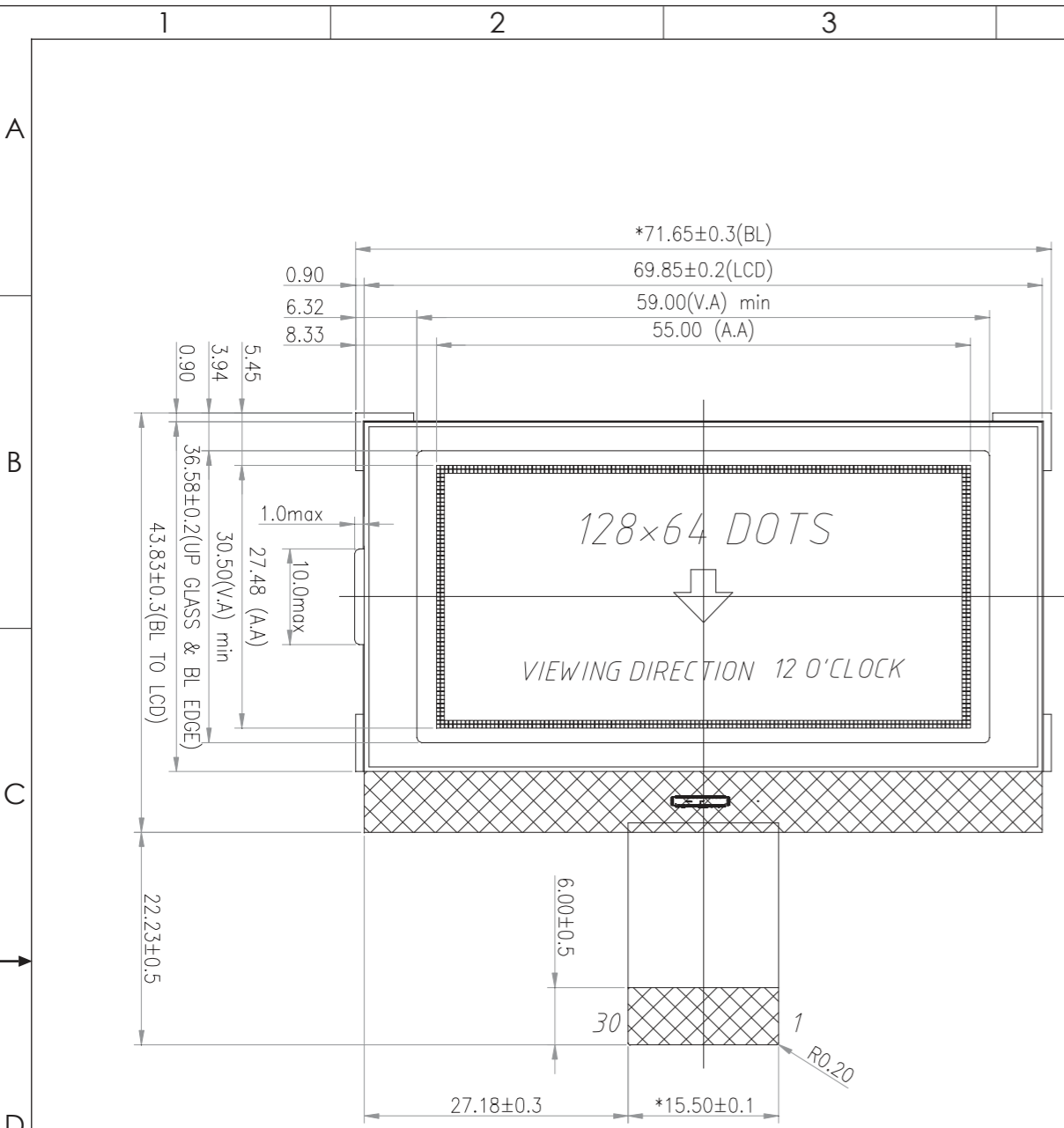

Pin No	Define
1	/CS1
2	/RES
3	A0
4	/WR
5	/RD
6	D0
7	D1
8	D2
9	D3
10	D4
11	D5
12	D6
13	D7
14	VDD
15	VSS
16	VOUT
17	CAP3-
18	CAP1+
19	CAP1-
20	CAP2-
21	CAP2+
22	V1
23	V2
24	V3
25	V4
26	V5
27	VR
28	C86
29	PS
30	/IRS

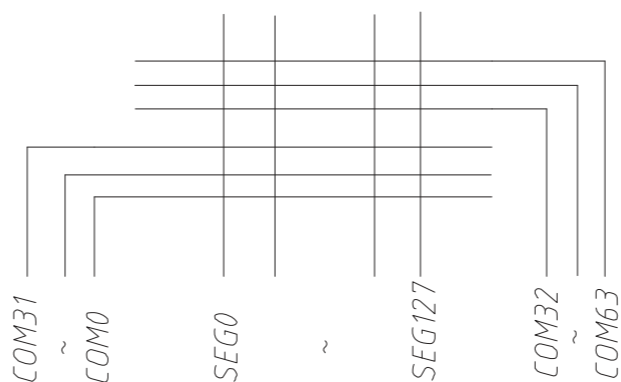
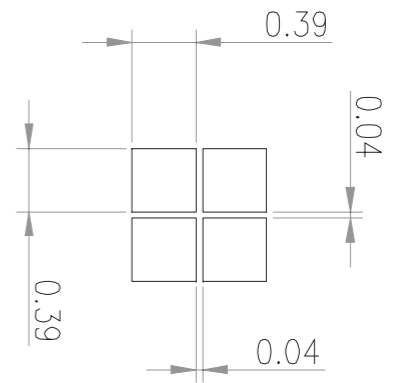
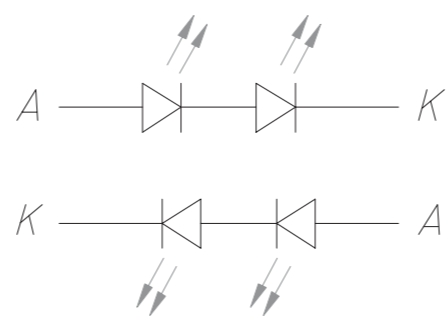

- Notes:**
1. Driver: 1/65 Duty, 1/9 Bias
 2. Display Mode: FSTN Positive / Transflective
 3. Optimal View: 12:00
 4. Voltage: 3.3V VDD, 9.5V VLCD
 5. Backlight: White LED
 6. Driver IC: ST7565

STANDARD TOLERANCES (UNLESS OTHERWISE SPECIFIED) LINEAR: XX. ±0.3 mm XX.X ±0.3 mm XX.XX ±0.3 mm			REVISION: 1.0
			SIZE: A3
DRAWING/PART NUMBER: NHD-C12864M1R-FSW-FTW-3V6		APPROVED BY: S. Baxi	SCALE: NS
UNLESS OTHERWISE SPECIFIED - DIMENSIONS ARE IN MILLIMETERS - THIRD ANGLE PROJECTION		DRAWN BY: S. Baxi	APPROVED DATE: 10/09/18
		CHECKED BY: S. Baxi	APPROVED DATE: 10/09/18
		APPROVED BY: S. Baxi	APPROVED DATE: 10/09/18
DO NOT SCALE DRAWING			SHEET 1 OF 2
THIS DRAWING IS SOLELY THE PROPERTY OF NEWHAVEN DISPLAY INTERNATIONAL, INC. THE INFORMATION IT CONTAINS IS NOT TO BE DISCLOSED, REPRODUCED OR COPIED IN WHOLE OR PART WITHOUT WRITTEN APPROVAL FROM NEWHAVEN DISPLAY.			

SYMBOL	REVISION	DATE

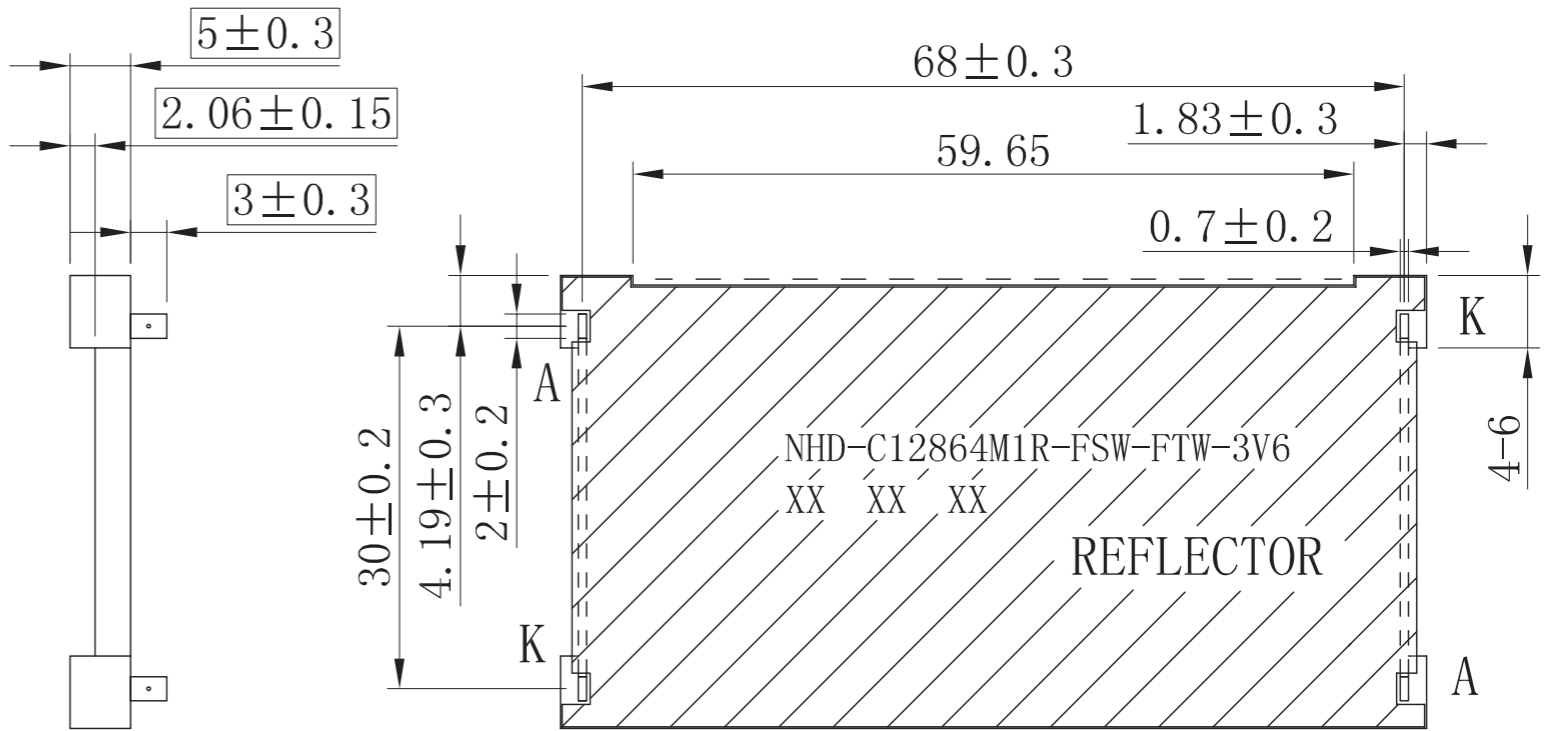
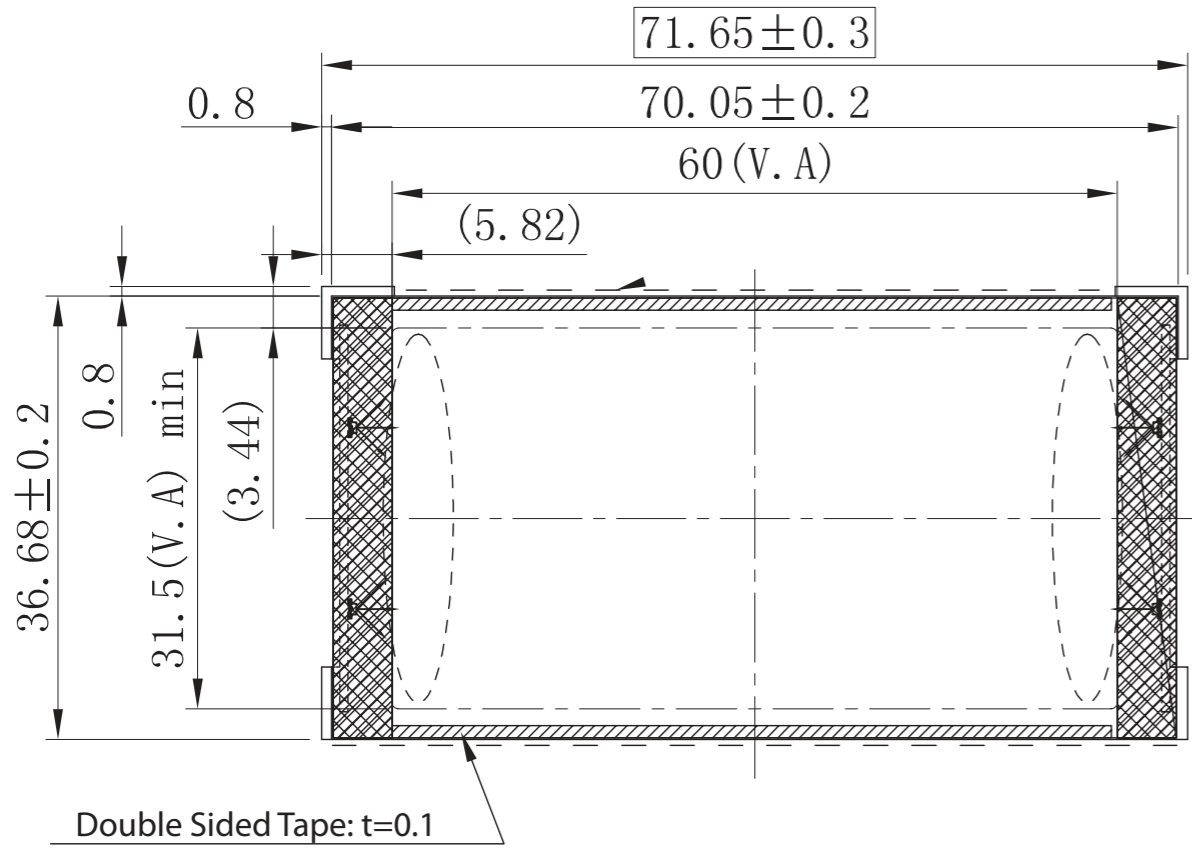

STANDARD TOLERANCES (UNLESS OTHERWISE SPECIFIED) LINEAR: XX. ± 0.3 mm XX.X ± 0.3 mm XX.XX ± 0.3 mm			
	DRAWING/PART NUMBER: NHD-C12864M1R-FSW-FTW-3V6		
UNLESS OTHERWISE SPECIFIED - DIMENSIONS ARE IN MILLIMETERS - THIRD ANGLE PROJECTION	DRAWN BY: S. Baxi	CHECKED BY: S. Baxi	APPROVED BY: S. Baxi
	DRAWN DATE: 10/09/18	CHECKED DATE: 10/09/18	APPROVED DATE: 10/09/18
DO NOT SCALE DRAWING			REVISION: 1.0 SIZE: A3 SCALE: NS
THIS DRAWING IS SOLELY THE PROPERTY OF NEWHAVEN DISPLAY INTERNATIONAL, INC. THE INFORMATION IT CONTAINS IS NOT TO BE DISCLOSED, REPRODUCED OR COPIED IN WHOLE OR PART WITHOUT WRITTEN APPROVAL FROM NEWHAVEN DISPLAY.			

Pin Description and Wiring Diagram

Pin No.	Symbol	External Connection	Function Description	
1	/CS1	MPU	Active LOW Chip Select	
2	/RES	MPU	Active LOW Reset signal	
3	A0	MPU	Register Select signal. 0: instruction; 1: data register	
4	R/W /WR	MPU	6800 Mode: Read/Write select signal. R/W=1: Read R/W=0: Write 8080 Mode: Active LOW Write Signal	
5	E /RD	MPU	6800 Mode: Active HIGH Enable Signal 8080 Mode: Active LOW Read Signal	
6	DB0	MPU	Parallel Interface DB0-DB7: Bi-directional 8-bit data bus Serial Interface: DB0-DB5: No connect in serial mode DB6= Serial clock (SCL) DB7= Serial data input (SI)	
7	DB1	MPU		
8	DB2	MPU		
9	DB3	MPU		
10	DB4	MPU		
11	DB5	MPU		
12	DB6 (SCL)	MPU		
13	DB7 (SI)	MPU		
14	V _{DD}	Power Supply		Power supply for LCD and logic (+3.3V)
15	V _{SS}	Power Supply		Ground
16	V _{OUT}	Power Supply	Connect to 1uF cap to VSS	
17	CAP3-	Power Supply	Connect to 1uF cap to CAP1+ (PIN-18)	
18	CAP1+	Power Supply	Connect to 1uF cap to CAP3-(PIN17) and CAP1-(PIN19)	
19	CAP1-	Power Supply	Connect to 1uF cap to CAP1+ (PIN-18)	
20	CAP2-	Power Supply	Connect to 1uF cap to CAP2+ (PIN-21)	
21	CAP2+	Power Supply	Connect to 1uF cap to CAP2- (PIN-20)	
22	V ₁	Power Supply	1.0uF-2.2uF cap to VSS	
23	V ₂	Power Supply	1.0uF-2.2uF cap to VSS	
24	V ₃	Power Supply	1.0uF-2.2uF cap to VSS	
25	V ₄	Power Supply	1.0uF-2.2uF cap to VSS	
26	V ₅	Power Supply	1.0uF-2.2uF cap to VSS	
27	V _R	-	No Connect	
28	C86	MPU	Select MPU interface pin. C86=H: 6800; C86=L: 8080	
29	PS	MPU	Parallel/Serial select. PS= H: Parallel; PS=L: Serial	
30	/IRS	MPU	Internal resistor select. Set HIGH to use internal resistors	

Recommended LCD connector: 0.5mm Pitch, 30 pin FFC. Molex p/n: 52892-3095

Backlight connector: -- **Mates with:** --

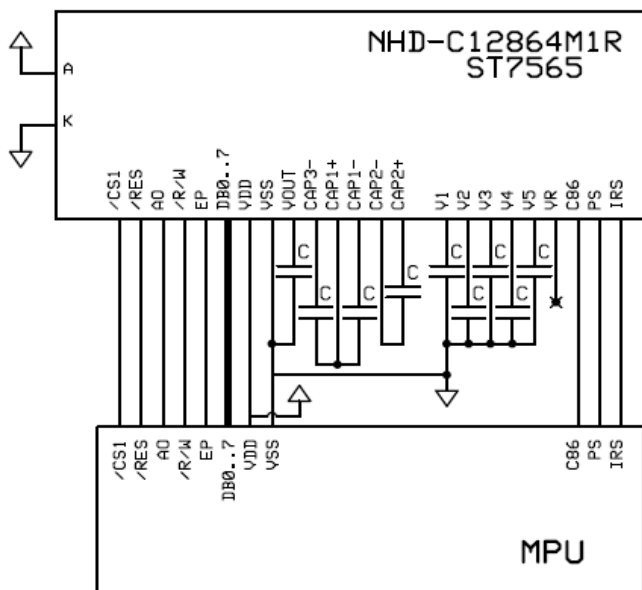

Electrical Characteristics

Item	Symbol	Condition	Min.	Typ.	Max.	Unit
Operating Temperature Range	T _{OP}	Absolute Max	-20	-	+70	°C
Storage Temperature Range	T _{ST}	Absolute Max	-30	-	+80	°C
Supply Voltage	V _{DD}	-	3.0	3.3	3.6	V
Supply Current	I _{DD}	V _{DD} = 3.3V T _{OP} = 25°C	-	0.25	0.50	mA
Supply for LCD (contrast)	V _{LCD}		9.2	9.5	9.8	V
"H" Level input	V _{IH}	-	0.8 * V _{DD}	-	V _{DD}	V
"L" Level input	V _{IL}	-	V _{SS}	-	0.2 * V _{DD}	V
"H" Level output	V _{OH}	-	0.8 * V _{DD}	-	V _{DD}	V
"L" Level output	V _{OL}	-	V _{SS}	-	0.2 * V _{DD}	V
Backlight Supply Current	I _{LED}	-	-	40	50	mA
Backlight Supply Voltage	V _{LED}	I _{LED} = 40mA	5.7	6.1	6.5	V

Optical Characteristics

Item	Symbol	Condition	Min.	Typ.	Max.	Unit
Optimal Viewing Angles	Top	CR ≥ 2	-	40	-	°
	Bottom		-	20	-	°
	Left		-	40	-	°
	Right		-	40	-	°
Contrast Ratio	CR	-	2	4	-	-
Response Time	Rise	T _{OP} = 25°C	-	150	250	ms
	Fall		-	150	250	ms

Controller Information

Built-in ST7565R controller.

Please download specification at http://www.newhavendisplay.com/app_notes/ST7565R.pdf

Timing Characteristics

System Bus Read/Write Characteristics 1 (For the 8080 Series MPU)

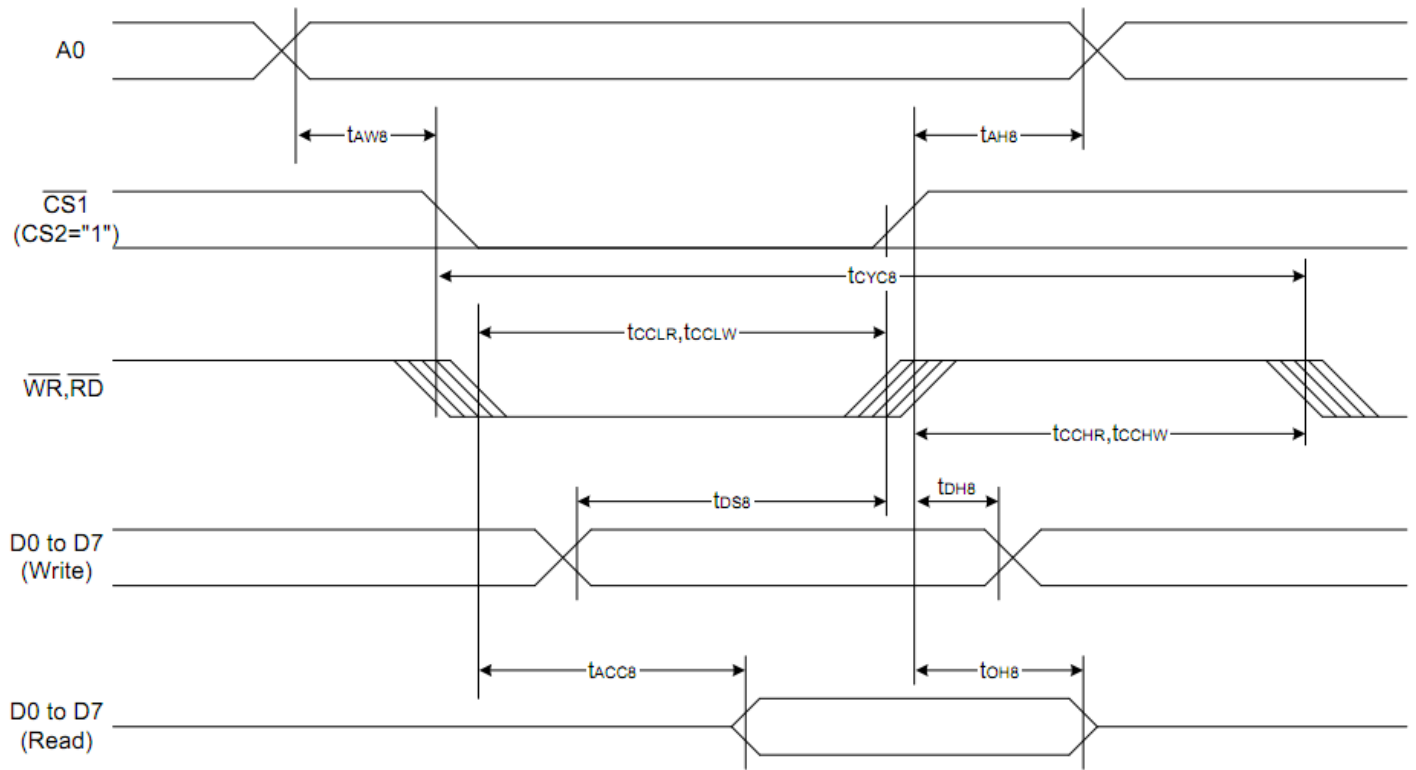

Item	Signal	Symbol	Condition	Rating		Units
				Min.	Max.	
Address hold time	A0	t_{AH8}		0	—	Ns
Address setup time		t_{AW8}		0	—	
System cycle time		t_{CYC8}		240	—	
Enable L pulse width (WRITE)	WR	t_{CCLW}		80	—	
Enable H pulse width (WRITE)		t_{CCHW}		80	—	
Enable L pulse width (READ)	RD	t_{CCLR}		140	—	
Enable H pulse width (READ)		t_{CCHR}		80	—	
WRITE Data setup time	D0 to D7	t_{DS8}		40	—	
WRITE Address hold time		t_{DH8}		0	—	
READ access time		t_{ACC8}	$C_L = 100 \text{ pF}$	—	70	
READ Output disable time		t_{OH8}	$C_L = 100 \text{ pF}$	5	50	

System Bus Read/Write Characteristics 2 (For the 6800 Series MPU)

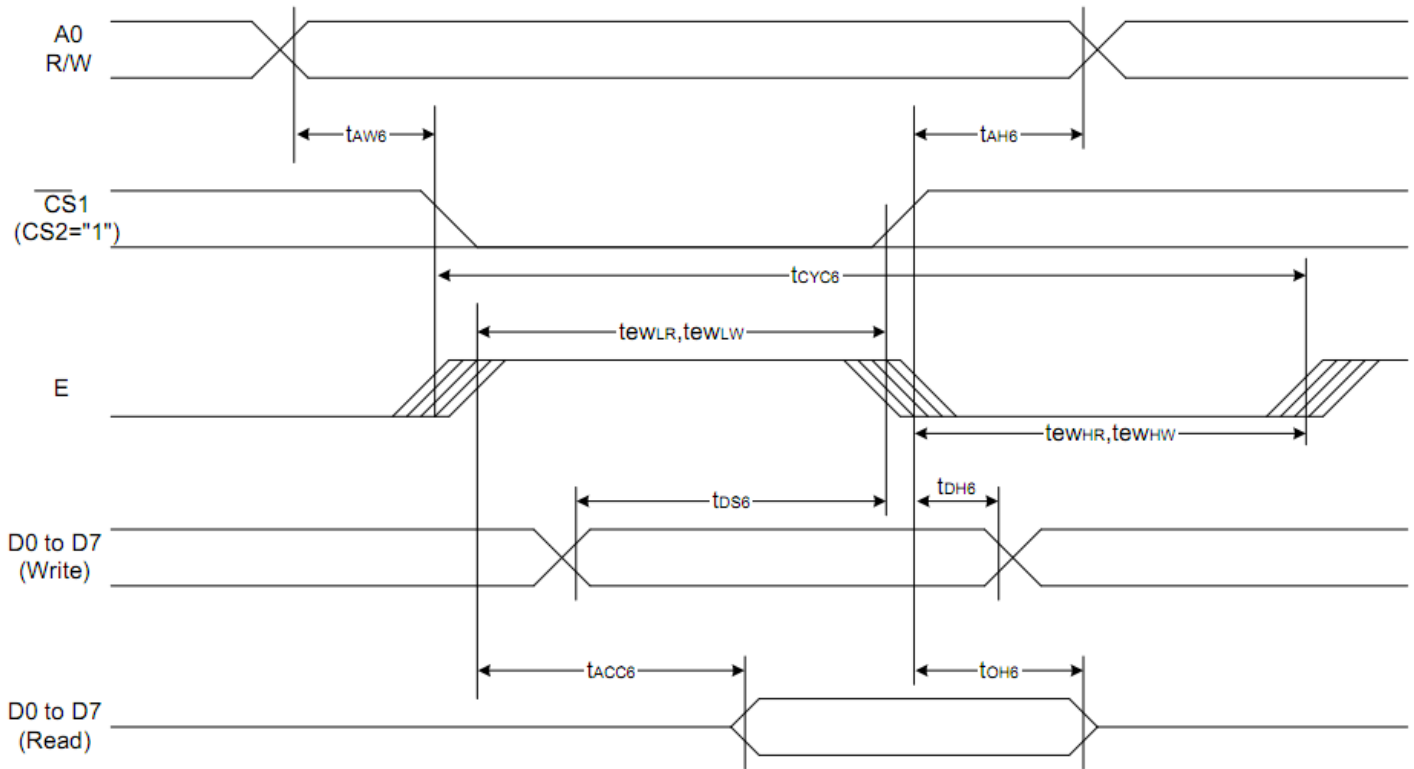

Item	Signal	Symbol	Condition	Rating		Units
				Min.	Max.	
Address hold time	A0	t_{AH6}		0	—	ns
Address setup time		t_{AW6}		0	—	
System cycle time		t_{CYC6}		240	—	
Enable L pulse width (WRITE)	WR	t_{EWLW}		80	—	
Enable H pulse width (WRITE)		t_{EWHW}		80	—	
Enable L pulse width (READ)	RD	t_{EWLR}		80	—	
Enable H pulse width (READ)		t_{EWHR}		140	—	
WRITE Data setup time	D0 to D7	t_{DS6}		40	—	
WRITE Address hold time		t_{DH6}		0	—	
READ access time		t_{ACC6}	$C_L = 100 \text{ pF}$	—	70	
READ Output disable time		t_{OH6}	$C_L = 100 \text{ pF}$	5	50	

The 4-line SPI Interface

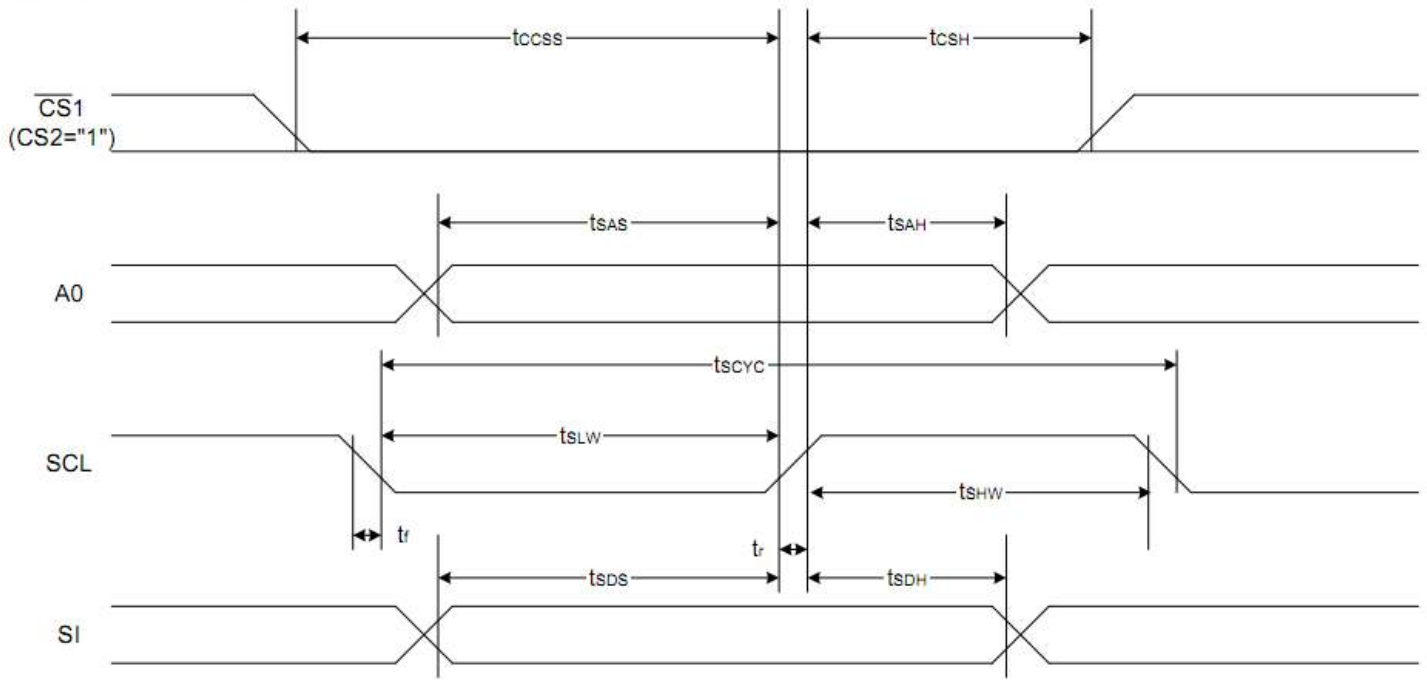

Item	Signal	Symbol	Condition	Rating		Units
				Min.	Max.	
4-line SPI Clock Period	SCL	T_{scyc}		50	—	ns
SCL "H" pulse width		T_{shw}		25	—	
SCL "L" pulse width		T_{SLW}		25	—	
Address setup time	A0	T_{SAS}		20	—	
Address hold time		T_{SAH}		10	—	
Data setup time	SI	T_{SDS}		20	—	
Data hold time		T_{SDH}		10	—	
CS-SCL time	CS	T_{CSS}		20	—	
CS-SCL time		T_{CSH}		40	—	

Table of Commands

Command	Command Code									Function			
	A0	/RD	/WR	D7	D6	D5	D4	D3	D2		D1	D0	
(1) Display ON/OFF	0	1	0	1	0	1	0	1	1	1	0	1	LCD display ON/OFF 0: OFF, 1: ON
(2) Display start line set	0	1	0	0	1	Display start address					0	Sets the display RAM display start line address	
(3) Page address set	0	1	0	1	0	1	Page address				0	Sets the display RAM page address	
(4) Column address set upper bit	0	1	0	0	0	0	1	Most significant column address			0	Sets the most significant 4 bits of the display RAM column address.	
Column address set lower bit				0	0	0	0	Least significant column address			0	Sets the least significant 4 bits of the display RAM column address.	
(5) Status read	0	0	1	Status			0	0	0	0	0	Reads the status data	
(6) Display data write	1	1	0	Write data						0	Writes to the display RAM		
(7) Display data read	1	0	1	Read data						0	Reads from the display RAM		
(8) ADC select	0	1	0	1	0	1	0	0	0	0	0	1	Sets the display RAM address SEG output correspondence 0: normal, 1: reverse
(9) Display normal/reverse	0	1	0	1	0	1	0	0	1	1	0	1	Sets the LCD display normal/ reverse 0: normal, 1: reverse
(10) Display all points ON/OFF	0	1	0	1	0	1	0	0	1	0	0	1	Display all points 0: normal display 1: all points ON
(11) LCD bias set	0	1	0	1	0	1	0	0	0	1	0	1	Sets the LCD drive voltage bias ratio 0: 1/9 bias, 1: 1/7 bias (ST7565R)
(12) Read-modify-write	0	1	0	1	1	1	0	0	0	0	0	0	Column address increment At write: +1 At read: 0
(13) End	0	1	0	1	1	1	0	1	1	1	0	0	Clear read/modify/write
(14) Reset	0	1	0	1	1	1	0	0	0	1	0	0	Internal reset
(15) Common output mode select	0	1	0	1	1	0	0	0	*	*	*	1	Select COM output scan direction 0: normal direction 1: reverse direction
(16) Power control set	0	1	0	0	0	1	0	1	Operating mode		0	0	Select internal power supply operating mode
(17) V ₀ voltage regulator internal resistor ratio set	0	1	0	0	0	1	0	0	Resistor ratio		0	0	Select internal resistor ratio(Rb/Ra) mode
(18) Electronic volume mode set	0	1	0	1	0	0	0	0	0	0	0	1	Set the V ₀ output voltage electronic volume register
Electronic volume register set				0	0	Electronic volume value					0	0	
(19) Sleep mode set	0	1	0	1	0	1	0	1	1	0	0	1	0: Sleep mode, 1: Normal mode
(20) Booster ratio set	0	1	0	1	1	1	1	1	0	0	0	0	select booster ratio 00: 2x,3x,4x 01: 5x 11: 6x
				0	0	0	0	0	0	0	0	step-up value	
(21) NOP	0	1	0	1	1	1	0	0	0	1	1	1	Command for non-operation
(22) Test	0	1	0	1	1	1	1	*	*	*	*	*	Command for IC test. Do not use this command

Example Initialization Program

```
'-----  
Sub Init  
Reset P3.7          'set Read/write to '0' for write  
Reset P3.0          'RS  
Set P3.1            'reset  
Reset P3.4 'E  
'Set P3.3  
'Reset P3.3  
Waitms 2  
'Set P3.3  
Waitms 20  
A = &HA2            '1/9 BIAS  
Call Writecom  
A = &HA0            'ADC SELECT , NORMAL  
Call Writecom  
A = &HC8            'COM OUTPUT REVERSE  
Call Writecom  
A = &HA4            'DISPLAY ALL POINTS NORMAL  
Call Writecom  
A = &H40            'DISPLAY START LINE SET  
Call Writecom  
A = &H25            'INTERNAL RESISTOR RATIO  
Call Writecom  
A = &H81            'ELECTRONIC VOLUME MODE SET  
Call Writecom  
A = &H10            'ELECTRONIC VOLUME  
Call Writecom  
A = &H2F            'POWER CONTROLLER SET  
Call Writecom  
A = &HAF            'DISPLAY ON  
Call Writecom  
End Sub
```

```
'-----  
Sub Writecom  
Reset P3.0          'A0 low  
Reset P3.7          'R/W low  
Set P3.6            'CS1  
Set P3.4            'E  
P1 = A  
Reset P3.4  
Reset P3.6  
Reset P3.7  
End Sub
```

```
Sub Writedata  
Set P3.0            'A0 high  
Reset P3.7          'R/W low  
Set P3.6            'CS1  
Set P3.4            'E  
P1 = A  
Reset P3.4  
Reset P3.6  
Reset P3.7  
End Sub
```

```
'-----
```

Quality Information

Test Item	Content of Test	Test Condition	Note
High Temperature storage	Endurance test applying the high storage temperature for a long time.	+80°C , 240hrs	2
Low Temperature storage	Endurance test applying the low storage temperature for a long time.	-30°C , 240hrs	1,2
High Temperature Operation	Endurance test applying the electric stress (voltage & current) and the high thermal stress for a long time.	+70°C 240hrs	2
Low Temperature Operation	Endurance test applying the electric stress (voltage & current) and the low thermal stress for a long time.	-20°C , 240hrs	1,2
High Temperature / Humidity Operation	Endurance test applying the electric stress (voltage & current) and the high thermal with high humidity stress for a long time.	+40°C , 90% RH , 240hrs	1,2
Thermal Shock resistance	Endurance test applying the electric stress (voltage & current) during a cycle of low and high thermal stress.	-20°C,30min -> 25°C,5min -> 70°C,30min = 1 cycle 10 cycles	
Vibration test	Endurance test applying vibration to simulate transportation and use.	10-55Hz , 15mm amplitude. 60 sec in each of 3 directions X,Y,Z For 15 minutes	3
Static electricity test	Endurance test applying electric static discharge.	VS=800V, RS=1.5kΩ, CS=100pF One time	

Note 1: No condensation to be observed.

Note 2: Conducted after 4 hours of storage at 25°C, 0%RH.

Note 3: Test performed on product itself, not inside a container.

See full Quality Specification at http://www.newhavendisplay.com/specs/quality_spec.pdf

Assembly Reliability Information

Test Item	Content of Test	Test Condition	Result	Note
High Temperature test on adhesive	Endurance of backlight adhesive applying high temperature for a long time.	60°C, 50% RH, 240hrs	>50N to separate backlight from LCD	1,2
Vibration test on adhesive	Endurance of backlight adhesive applying vibration to simulate transportation and use.	30Hz, 10min 35Hz, 10min 40Hz, 20min 45Hz, 20min	>50N to separate backlight from LCD	3
Drop test on adhesive	Endurance of backlight adhesive applying drop force to simulate transportation and use.	Corner: 25cm, 1 drop Edge: 25cm, 1 drop Face: 100cm, 1 drop	>50N to separate backlight from LCD	4

Note 1: No condensation to be observed.

Note 2: Conducted immediately after test condition.

Note 3: Test performed on product itself, not inside a container.

Note 4: Test performed inside standard shipping packaging.

Precautions for using LCDs/LCMs

See Precautions at www.newhavendisplay.com/specs/precautions.pdf

Warranty Information and Terms & Conditions

http://www.newhavendisplay.com/index.php?main_page=terms