

THIS DRAWING IS UNPUBLISHED. RELEASED FOR PUBLICATION
 © COPYRIGHT BY TYCO ELECTRONICS CORPORATION. ALL RIGHTS RESERVED.

LOC		DIST		REVISIONS			
P	LTR	DESCRIPTION		DATE	DWN	APVD	
	A	REVISED PER ECO-07-029644		1/11/08	SS	MW	

SPECIFICATIONS:

MATERIALS:

CASE: THERMOSET.
 ACTUATOR BUTTON: THERMOPLASTIC. COLOR: SEE CHART.
 MOVING CONTACT: COPPER ALLOY, SILVER PLATE.
 FIXED CONTACT: COPPER ALLOY, SILVER PLATE.
 TERMINALS: COPPER ALLOY, SILVER PLATE.
 TERMINAL SEAL: EPOXY.

ELECTRICAL:

CONTACT RATING: 0.5 AMPS AT 125 VAC.
 INITIAL CONTACT RESISTANCE: 100 MILLIOHMS.
 INSULATION RESISTANCE: 1,000 MEGOHMS MIN.
 DIELECTRIC STRENGTH: 1000V RMS AT SEA LEVEL.
 LIFE EXPECTANCY: 10,000 CYCLES.

MECHANICAL:

ACTUATION TRAVEL: .098.

ENVIRONMENTAL:

OPERATING TEMPERATURE: -4°F TO +176°F (-20°C TO +80°C).
 STORAGE TEMPERATURE: -4°F TO +176°F (-20°C TO +80°C).

NOTES:

- INTERPRET DRAWING PER ASME Y14.5M-1994.
- SUPPLIED WITH MOUNTING HARDWARE:
 (1) WASHER
 (1) N-35 DECORATIVE NUT
 (1) HEX NUT.
- RECOMMENDED HAND SOLDER TEMP. OF 420C FOR 5 SECONDS.

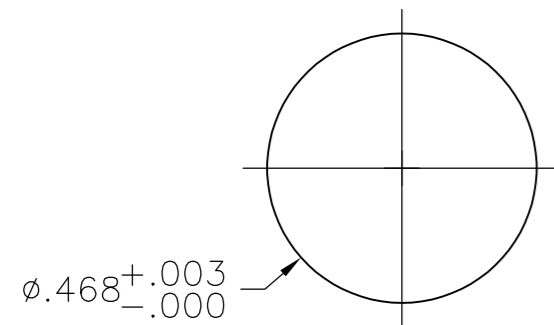
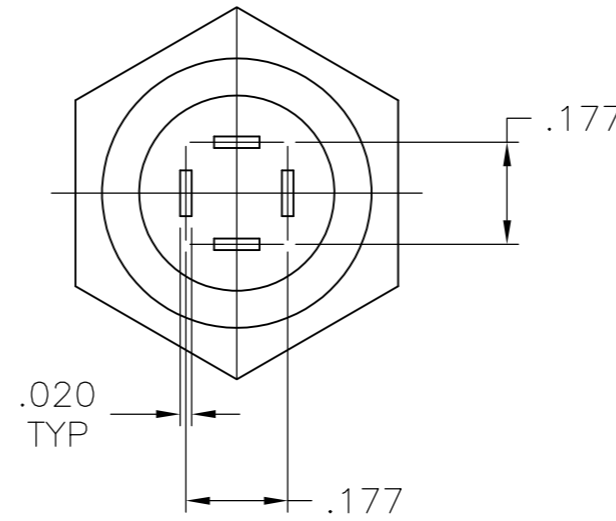
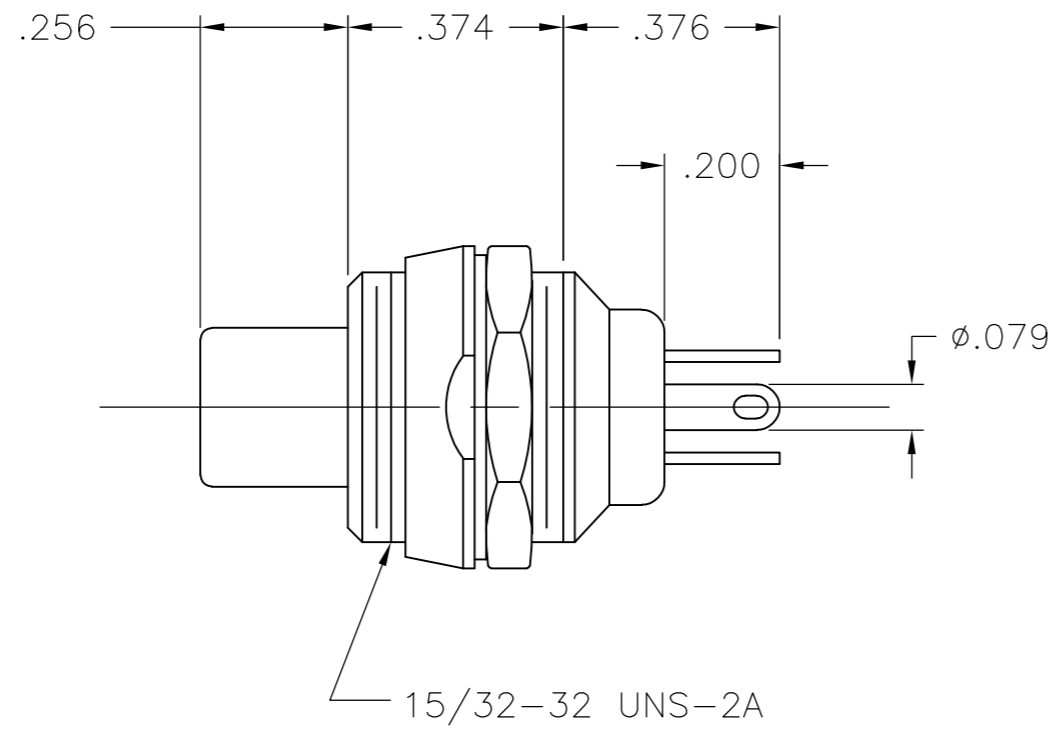
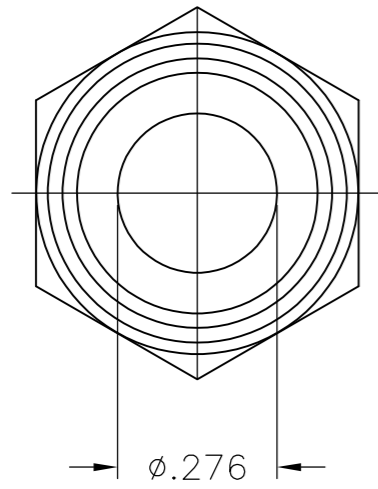

RECOMMENDED PANEL CUTOUT

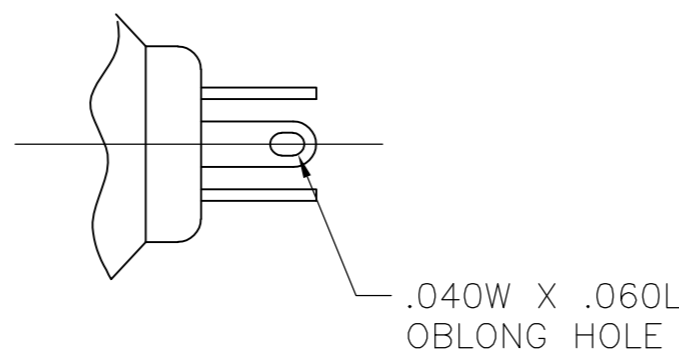

TERMINAL DETAIL

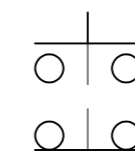

NORMALLY OPEN / NORMALLY CLOSED

CIRCUIT DIAGRAM

NORMALLY OPEN / NORMALLY CLOSED	2 CKT	WHITE	MSPF-101BC-9	9-1437567-2
NORMALLY OPEN / NORMALLY CLOSED	2 CKT	BLUE	MSPF-101BC-6	9-1437567-1
NORMALLY OPEN / NORMALLY CLOSED	2 CKT	RED	MSPF-101BC-2	9-1437567-0
NORMALLY OPEN / NORMALLY CLOSED	2 CKT	BLACK	MSPF-101BC-0	8-1437567-9
ACTION	TYPE	ACTUATOR COLOR	MODEL NO.	PART NUMBER

THIS DRAWING IS A CONTROLLED DOCUMENT.		DWN	S	SCHLEGEL	11JAN2008	Tyco Electronics Corporation Harrisburg, PA 17105-3608	
DIMENSIONS: INCHES		CHK	M	WILBOURN	1/16/08	NAME	
TOLERANCES UNLESS OTHERWISE SPECIFIED:		APVD	M	WILBOURN	1/16/08	PRODUCT SPEC	
0 PLC ± -		APVD		M	WILBOURN	APPLICATION SPEC	
1 PLC ± -		NAME		PUSH BUTTON MOMENTARY (MSPF-101BC SERIES)		RESTRICTED TO	
2 PLC ± -		SIZE		A2	CAGE CODE		DRAWING NO
3 PLC ± .010		SCALE		00779		9-1437567-1	
4 PLC ± -		SHEET		1		OF 1	
ANGLES ± 1°		REV		A			
FINISH		CUSTOMER DRAWING		SCALE		NTS	