

Description

The IDT SGAS701 is a solid-state chemiresistor sensor designed to detect hydrogen in air. The sensor uses an integrated heater with highly sensitive MOx material tailored for detection of hydrogen.

The chemiresistor sensors of IDT's SGAS family are based upon the principle that metal oxide materials undergo surface interactions (physisorption and chemisorption) with gas molecules at elevated temperatures, resulting in a measurable change in electrical resistance. As these materials are polycrystalline (i.e., composed of multiple grains with distinct grain boundaries), the adsorbed gases have significant electronic effects on the individual grains. These gas-solid interactions result in a change in electron (or hole) density at the surface (i.e., a space charge forms), which in turn changes the electrical conductivity of the oxide. IDT has developed a set of nanostructured gas sensing materials with excellent sensitivity and stability.

Figure 1. Product Photo



Features

- High sensitivity to low hydrogen concentrations (< 10 to 1000 ppm)
- Fast response time (<15 seconds at 100ppm)
- Environmental temperature range of -20°C to 50°C
- Environmental humidity range of 0% to 90% RH, noncondensing
- Low dependence on flow rate
- Rugged, reliable sensor based on IDT's exclusive technology

Typical Applications

- Leak Detection
- Gas Concentration Detection
- Breath Detection

Available Support

- Evaluation Kit – SMOD701KITV1
- Application Notes
- Instruction Videos
- Reference Design

Contents

1. Pin Assignments.....	4
2. Pin Descriptions.....	4
3. Sensor Specifications.....	4
4. Sensor Characteristics.....	5
5. Basic Measurement Circuit.....	6
6. Heater Driver Circuits and Control.....	7
6.1 Constant Voltage Drive.....	7
6.2 Constant Current Drive.....	8
6.3 Pulse-Width Modulation.....	8
6.4 Operating the Sensor at Temperature Extremes.....	9
7. Sensing Characteristics.....	10
7.1 Sensitivity.....	10
7.2 Response and Recovery Time.....	12
7.3 Cross-Sensitivity.....	13
8. Maximum ESD Ratings.....	14
9. Mechanical Stress Testing.....	14
10. Package Drawing and Dimensions.....	15
11. Applications and Use Conditions.....	16
12. Ordering Information.....	16
13. Revision History.....	16

List of Figures

Figure 1. Product Photo.....	1
Figure 2. Pin Assignments for SGAS701 – Top View.....	4
Figure 3. Typical Sensor Response Characteristic.....	6
Figure 4. Basic Measurement Circuit.....	6
Figure 5. Three-Terminal Voltage Regulator.....	7
Figure 6. Voltage-Controlled Constant Current Circuit.....	8
Figure 7. Recommended Applied Heater Voltage as a Function of Environmental Temperature.....	9
Figure 8. Typical Sensor Response to a Range of Hydrogen Concentrations in a Background of 30% RH at Room Temperature.....	10
Figure 9. Typical Sensor Sensitivity to a Range of Hydrogen Concentrations in a Background of 30% RH at Room Temperature.....	11
Figure 10. Typical Sensor Response to Step Changes in Hydrogen Concentration for Four SGAS701 Sensors.....	12
Figure 11. Typical Sensor Response to other Common Gases.....	13
Figure 12. TO-39 Package (TO4) Outline Drawing PSC-4676.....	15

List of Tables

Table 1. Pin Descriptions.....4

Table 2. Electrical Specifications.....4

Table 3. Temperature Specifications.....5

Table 4. Maximum ESD Ratings14

Table 5. Mechanical Stress Test Conditions14

1. Pin Assignments

Figure 2. Pin Assignments for SGAS701 – Top View

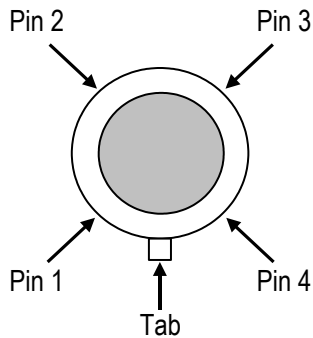

2. Pin Descriptions

Table 1. Pin Descriptions

Pin Number	Name	Description
1	Heater +	Positive input for V_H heater voltage supply
2	Sensor +	High-side of resistive sensor element; positive input for sensing voltage V_C
3	Heater –	Negative (ground) input for V_H heater voltage supply
4	Sensor –	Low-side of resistive sensor element; connects to middle of resistor divider circuit to produce sensing voltage output (V_{OUT})

3. Sensor Specifications

Note: All measurements were made in dry gas at room temperature. Specifications are subject to change.

Table 2. Electrical Specifications

Symbol	Parameter	Conditions	Minimum	Typical	Maximum	Units
P_H	Heater power consumption	$V_H = 5.4V$		600		mW
V_H	Recommended heater voltage	$T_{SENSOR} = 240^{\circ}C$		5.4		VDC
R_H	Heater resistance	At room temperature	28	30	32	Ω
V_C	Recommended sensing voltage		2.5		5.0	VDC
R_{10}	Resistance in 10ppm H_2		30		3000	k Ω
R_{100}	Resistance in 100ppm H_2		10		1000	k Ω
R_{50} / R_{100}	Resolution: Resistance in 50 ppm / Resistance in 100 ppm		> 1.2			

Table 3. Temperature Specifications

Symbol	Parameter	Conditions	Minimum	Typical	Maximum	Units
T _{OP}	Sensor Operation Temperature	V _H = 5.4V		240		°C
T _{AMB}	Recommended Environmental Temperature Range		-20		50	°C
T _{STOR}	Maximum Storage Temperature Range		-50		125	°C

The sensor is not intended for continuous operation above or below the environmental temperature specification, but exposure for short durations will not harm the sensor.

4. Sensor Characteristics

IDT's solid-state chemiresistive sensors are an advanced type of gas-sensitive resistor; i.e. they sense the presence of a target gas through a change in resistance of the sensing element. Most sensors exhibit reduced resistance as gas concentration increases, typically over several orders of magnitude across the sensing range.

Solid-state chemiresistive sensors show a reduced resistance with increasing gas concentration according to Equation 1:

$$R_S = A * C^{-\alpha} \tag{Equation 1}$$

where R_S is resistance, C is concentration, and A and α are constants. Although several refined versions of this equation are available for specific sensors or sensing materials, the fundamental resistance versus concentration relationship for all of IDT's n-type sensors follows Equation 1. Taking the log of both sides of the equation results in Equation 2:

$$\log(R_S) = \log(A) - \alpha * \log(C) \tag{Equation 2}$$

This shows that log resistance versus log concentration is linear.

An immediately observable consequence of Equation 1 is that sensor resistance will change rapidly at low concentrations and much less at high concentrations. This is illustrated in the following example:

$$\begin{aligned} R_{GAS_10ppm} &= 20k\Omega \\ R_{GAS_100ppm} &= 5k\Omega \\ A_{GAS} &= 8.0 * 10^4 \\ \alpha_{air} &= 0.602 \end{aligned}$$

The non-logarithmic response plot shown in Figure 3 illustrates the fundamental challenge that must be addressed when measuring the resistance of chemiresistor sensors and relating these measurements to gas concentrations. Additional nonlinear effects from the measurement circuitry exacerbate these challenges and must be understood in order to account for or eliminate these effects.

Figure 3. Typical Sensor Response Characteristic

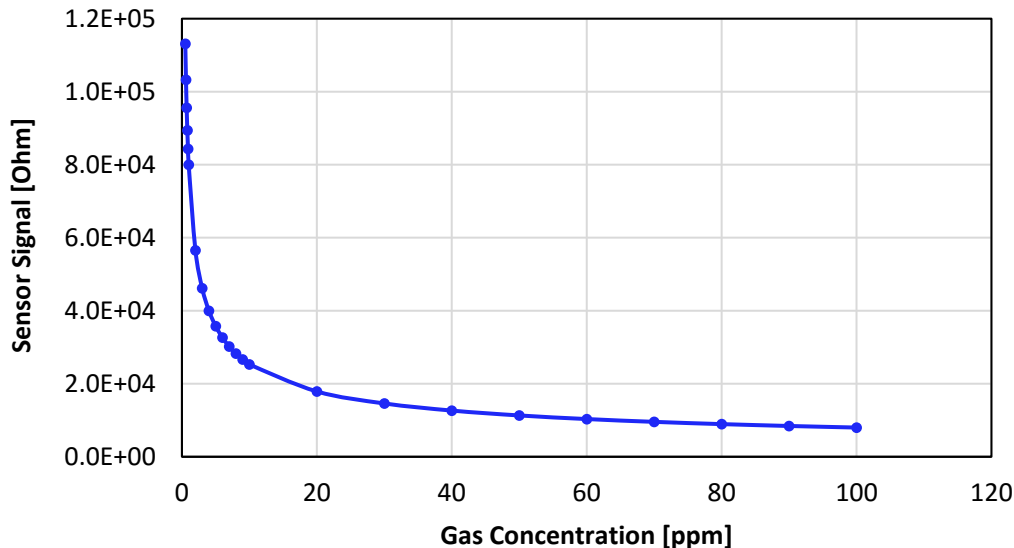

The electronic instrumentation used to detect this change in resistance influences the quality and accuracy of the gas sensing result. In particular, the choice of the analog front-end used to measure resistance can ultimately have a significant effect on overall measurement characteristics and must be selected with care. For additional information, see IDT's *Application Note – Resistance Measuring Circuits for SGAS Sensors*.

5. Basic Measurement Circuit

The sensor can be operated using a simple voltage divider. This requires two voltage supplies: the heater voltage (V_H) and circuit voltage (V_C). V_H is applied to the heater in order to maintain a constant, elevated temperature for optimum sensing. V_C is applied to allow a measurement of the output voltage (V_{OUT}) across a load resistor (R_L).

Figure 4. Basic Measurement Circuit

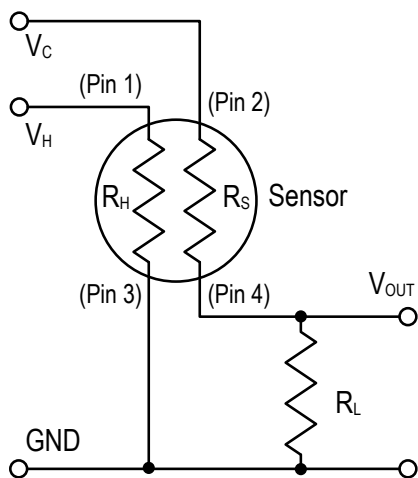

Pins 1 and 3 are attached to the heater. Apply V_H across these pins. Pins 2 and 4 are attached to the resistive sensor element. Connect these pins in the measurement circuit. IDT supplies basic measurement circuitry for many of our sensors. More information can be found in IDT's *Application Note – Resistance Measuring Circuits for SGAS Sensors*.

6. Heater Driver Circuits and Control

The SGAS701 sensor contains a resistive element that is used to heat the sensor to the target operating temperature as shown in Table 3. The SGAS701 sensor uses a thermistor heater element with a positive temperature coefficient, i.e. the heater resistance increases from the cold (room temperature) resistance as power is applied. This provides the opportunity for constant power and constant resistance (closely related to constant temperature) control of the heater.

6.1 Constant Voltage Drive

The simplest method of applying heater power is the use of a *constant voltage drive*. Because heaters draw a relatively large amount of current in normal operation, a method of current amplification is required. Additionally, because relatively small changes in voltage levels will affect the temperature of the heater (and consequently gas sensitivity), voltage regulation is required.

An easily implemented control circuit utilizes a three-terminal voltage regulator, with the LM317 serving as an example as shown in Figure 5.

Figure 5. Three-Terminal Voltage Regulator

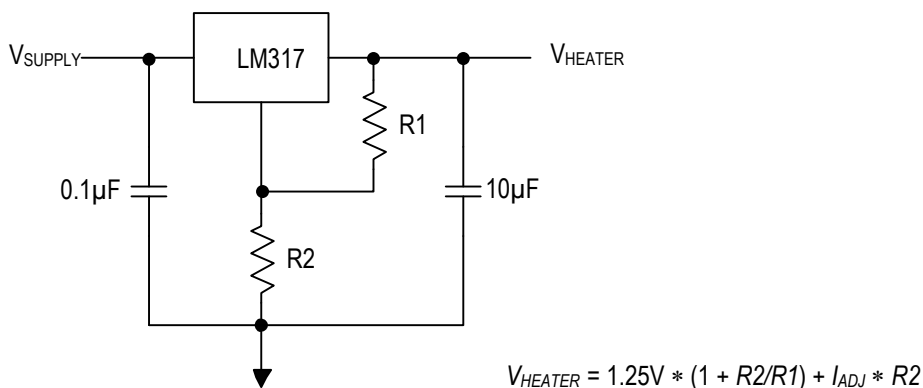

R1 and R2 (one of these can be a potentiometer) are selected to provide the target heater drive voltage for the sensor. The example using the LM317 is capable of regulating voltages down to 1.25V and is thus suitable for SGAS701 sensors. However, a wide variety of more advanced three-terminal voltage regulators is available from component manufacturers.

Constant voltage circuits of this type are relatively efficient, particularly if a switching regulator is used. Adding external control of the regulator output voltage with a current sensing resistor would allow feedback control of the sensor heater power and temperature, but the required circuitry is somewhat complex. Applications requiring feedback control are better implemented with the constant current circuit that is described in section 6.2.

6.2 Constant Current Drive

The *constant current drive* is more complex and costly than the constant voltage drive, but the added capabilities justify the expense for many applications. Additionally, the circuit is “microcontroller friendly” because the heater current is directly controllable via an input voltage signal, and feedback control of the heater is possible through a simple measurement of the resultant voltage on the heater.

The constant current heater drive circuit is shown in Figure 6. V_{IN} (supplied by an external source) is forced across $R1$, thus providing a predictable current through both $R1$ and $R2$, with a predictable voltage drop (relative to V_{DD}) across $R2$. An equivalent drop is imposed across $R3$, and current through both $R3$ and R_{HEATER} is thus controlled independently of the load resistance according to the equation in Figure 6.

The heater current is controllable to below 1mA. However, the circuit is inefficient compared to others, as power is dissipated in $R3$ and $Q2$ as well as the heater. Limiting the supply voltage to several hundred mV above the highest required drive voltage will help increase circuit efficiency.

While V_{IN} can be supplied by a fixed voltage reference (such as a divider), the flexibility of the circuit is most revealed when V_{IN} is supplied by a microcontroller via a digital-to-analog converter (DAC). With this type of control, the heater drive can be time-programmed to allow pulsing of the heater with variable amplitude. Determination of the heater power or resistance is possible by reading the voltage level at the heater. Since the heater temperature directly correlates with heater resistance, direct feedback control of bulk heater temperature is possible by raising or lowering the heater current such that (V_{HEATER}/I_{HEATER}) is constant. Likewise, constant heater power can be maintained by controlling current to keep $(V_{HEATER} * I_{HEATER})$ constant.

Figure 6. Voltage-Controlled Constant Current Circuit

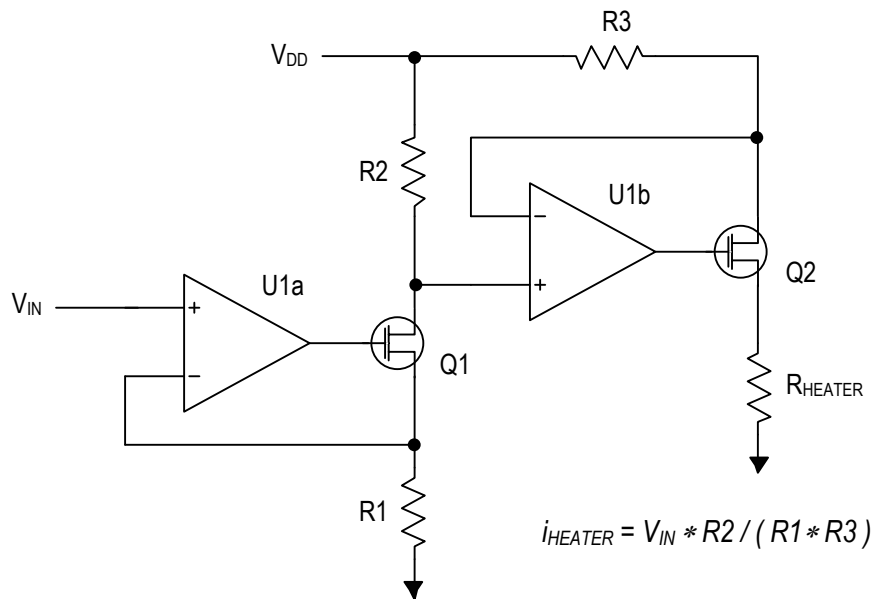

6.3 Pulse-Width Modulation

Pulse-width modulation (PWM) is a very efficient method of providing controllable drive to the heater. However, this method has not undergone sufficient testing at IDT to allow IDT to recommend it for any sensors in the SGAS family.

PWM heater drive design should keep the following in mind:

- Voltage to the heater should not exceed the maximum voltage allowed for a given heater family.
- A low-pass filter should be considered as part of the sensor signal circuit path to reduce noise from the heater PWM.

6.4 Operating the Sensor at Temperature Extremes

When this sensor is used outdoors, the relative response of the sensor to the target gases will be a function of environmental temperature when the sensor is operated with a constant voltage or current applied to the heater. This behavior is readily explained by considering that large shifts in ambient temperatures affect the operating temperature at the sensor surface, in turn altering the kinetics and thermodynamics of the interaction of the sensing surface with flammable gases. This alters the electrical conduction of the sensor element (the basis of metal-oxide sensor operation). Recommendation: In these cases, operate the sensor in a feedback loop, where constant resistance at the heater is maintained. For operation in ambient conditions above $T_{AMB} = 50^{\circ}\text{C}$, additional compensation of the sensor signal may be required and should be developed by the user with the specific application and operating conditions in mind. A graphical representation of the recommended temperature set-point voltage versus environmental temperature is shown in Figure 7.

The mathematical description for the curve is given in Equation 3:

$$V_H = -0.01 * \text{Environmental Temperature } [^{\circ}\text{C}] + 5.5 \tag{Equation 3}$$

Figure 7. Recommended Applied Heater Voltage as a Function of Environmental Temperature

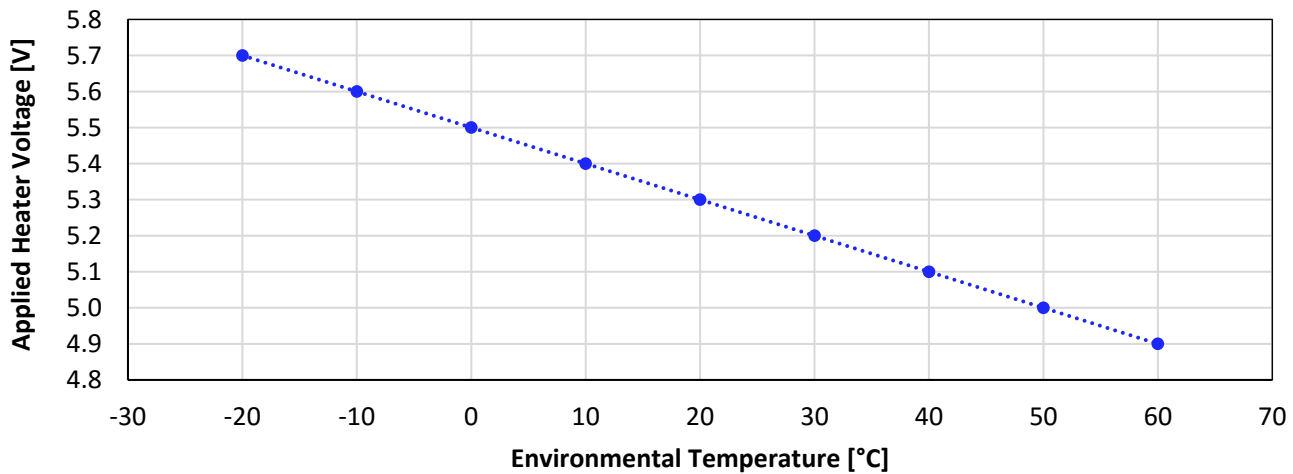

7. Sensing Characteristics

The following graphs show the typical responses that are to be expected from the sensors on exposure to a variety of test conditions. For SGAS701 sensor specifications, refer to Table 4.

7.1 Sensitivity

The typical response and sensitivity of the SGAS701 sensor to hydrogen is shown in Figure 8 and Figure 9. Sensitivity is defined as the ratio between the resistance in air (R_{Air}) and the resistance in gas (R_{Gas}).

Figure 8. Typical Sensor Response to a Range of Hydrogen Concentrations in a Background of 30% RH at Room Temperature

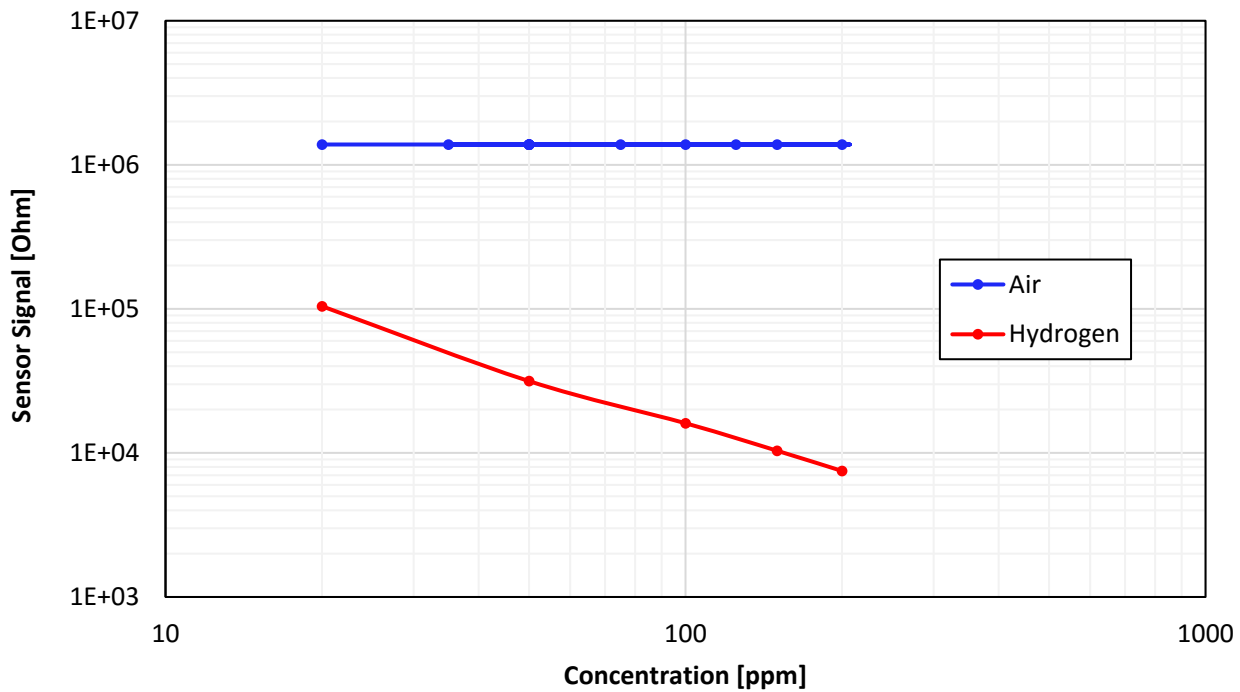
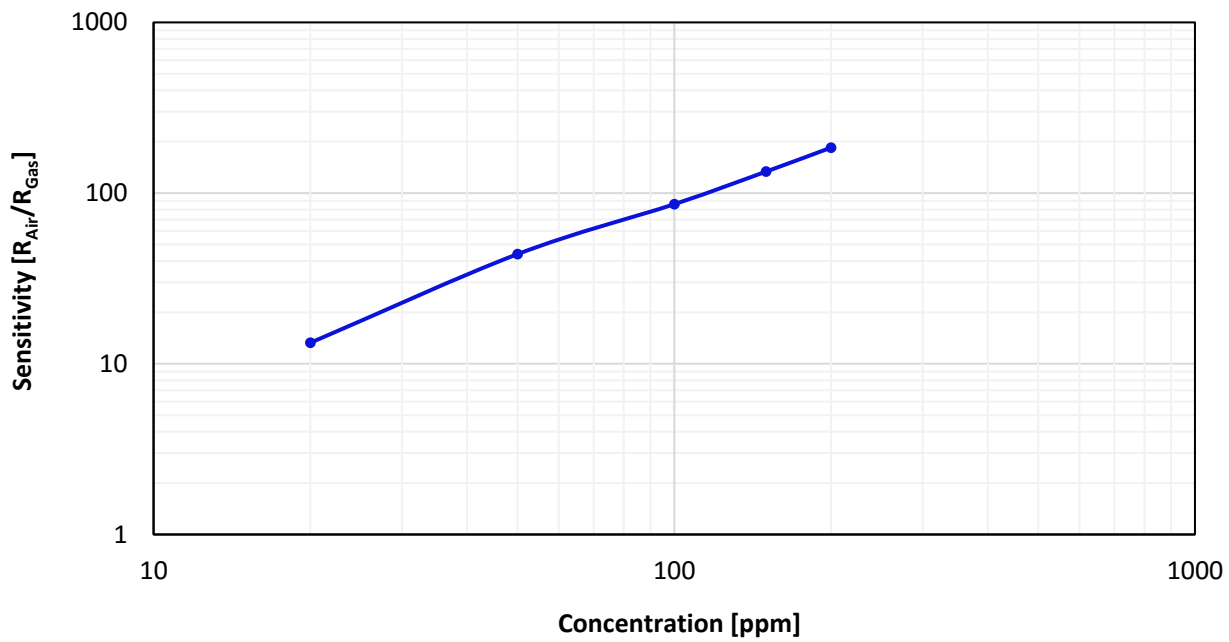

Figure 9. Typical Sensor Sensitivity to a Range of Hydrogen Concentrations in a Background of 30% RH at Room Temperature



7.2 Response and Recovery Time

The typical response and recovery time of a sampling of seven SGAS701 sensors is shown in Figure 10. The response and recovery time can be strongly affected by the sensor location within the system, including any barriers to diffusion of gas to and from the sensor surface, and whether the sensor is operated with or without a pump or other source of external flow.

Figure 10. Typical Sensor Response to Step Changes in Hydrogen Concentration for Four SGAS701 Sensors

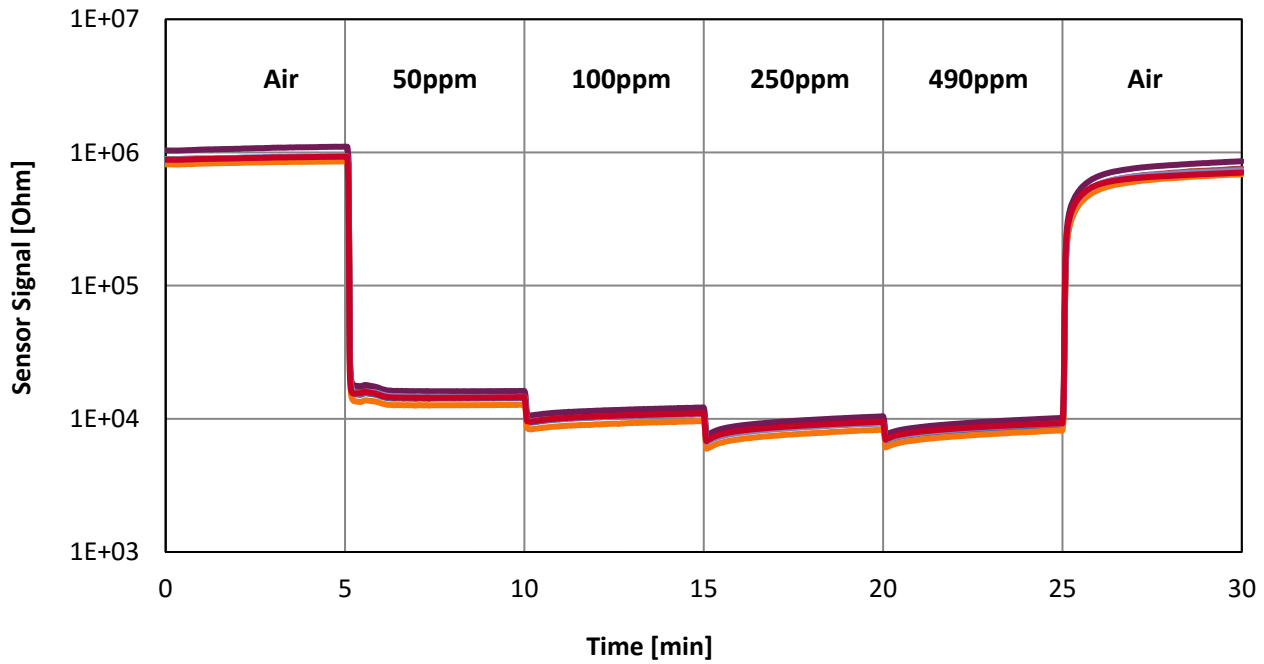

7.3 Cross-Sensitivity

The response of the SGAS701 sensors to a range of other common gases is shown in Figure 11.

Figure 11. Typical Sensor Response to other Common Gases

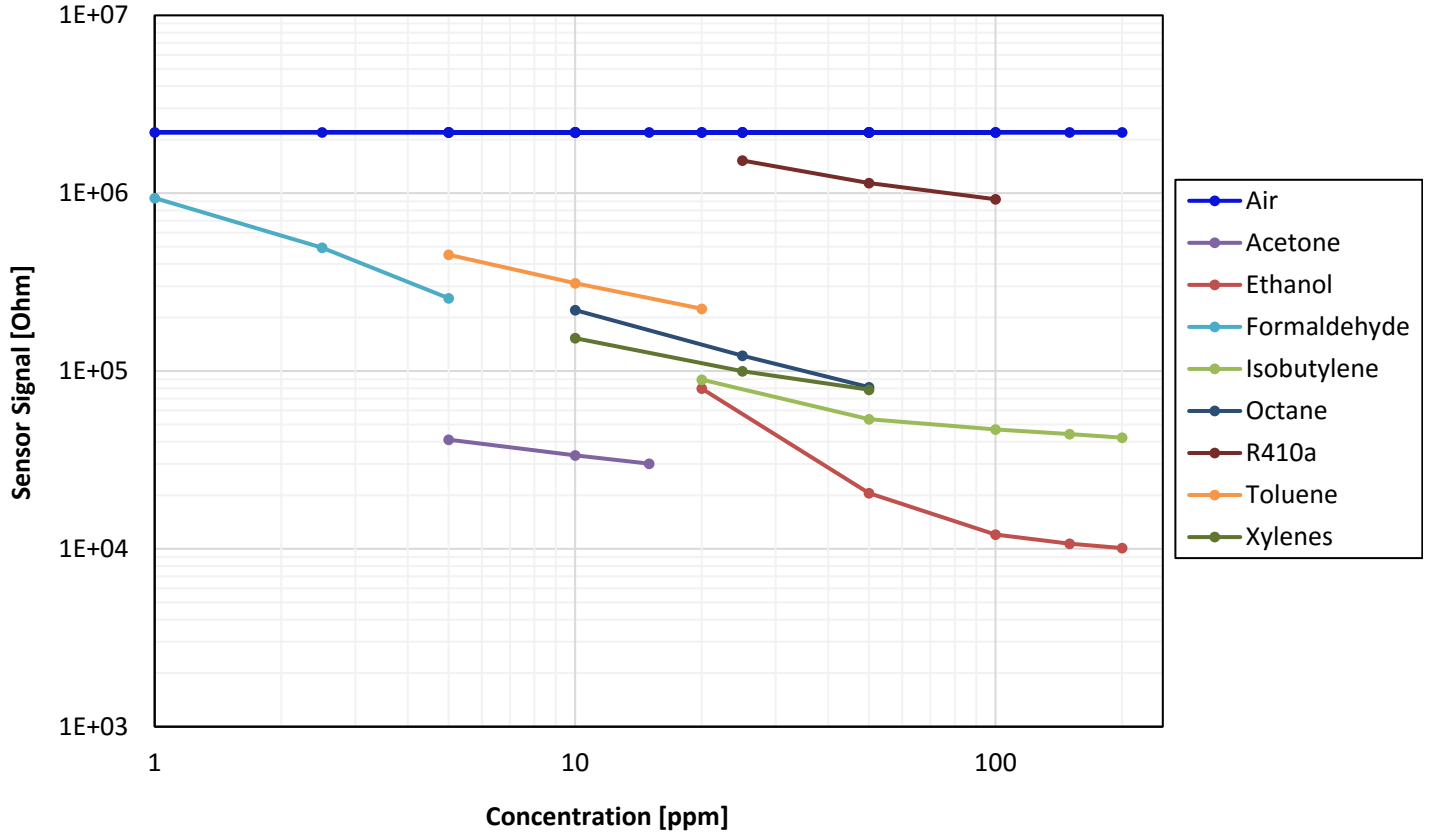

8. Maximum ESD Ratings

Table 4. Maximum ESD Ratings

Symbol	Parameter	Conditions	Minimum	Maximum	Units
V _{HBM1}	Electrostatic Discharge Tolerance – Human Body Model (HBM1)		2000	–	V
V _{CDM}	Electrostatic Discharge Tolerance – Charged Device Model (CDM) on Packaged Module		500	–	V

9. Mechanical Stress Testing

The qualification of the SGAS701 is based on the JEDEC standard (JESD47).

After subjection to the mechanical shock and vibration testing conditions given in Table 5 the SGAS701 sensor will meet the specifications given in this document. For information on constant acceleration test conditions and limits, contact IDT (see contact information on last page).

Table 5. Mechanical Stress Test Conditions

Stress Test	Standard	Conditions
Mechanical Shock	JESD22-B104, M2002	Y1 plane only, 5 pulses, 0.5 ms duration, 1500 g peak acceleration
Vibration Variable Frequency	JESD22-B103, M2007	20Hz to 2kHz (log variation) in > 4 minutes, 4 times in each orientation, 50g peak acceleration

10. Package Drawing and Dimensions

Figure 12. TO-39 Package (TO4) Outline Drawing PSC-4676

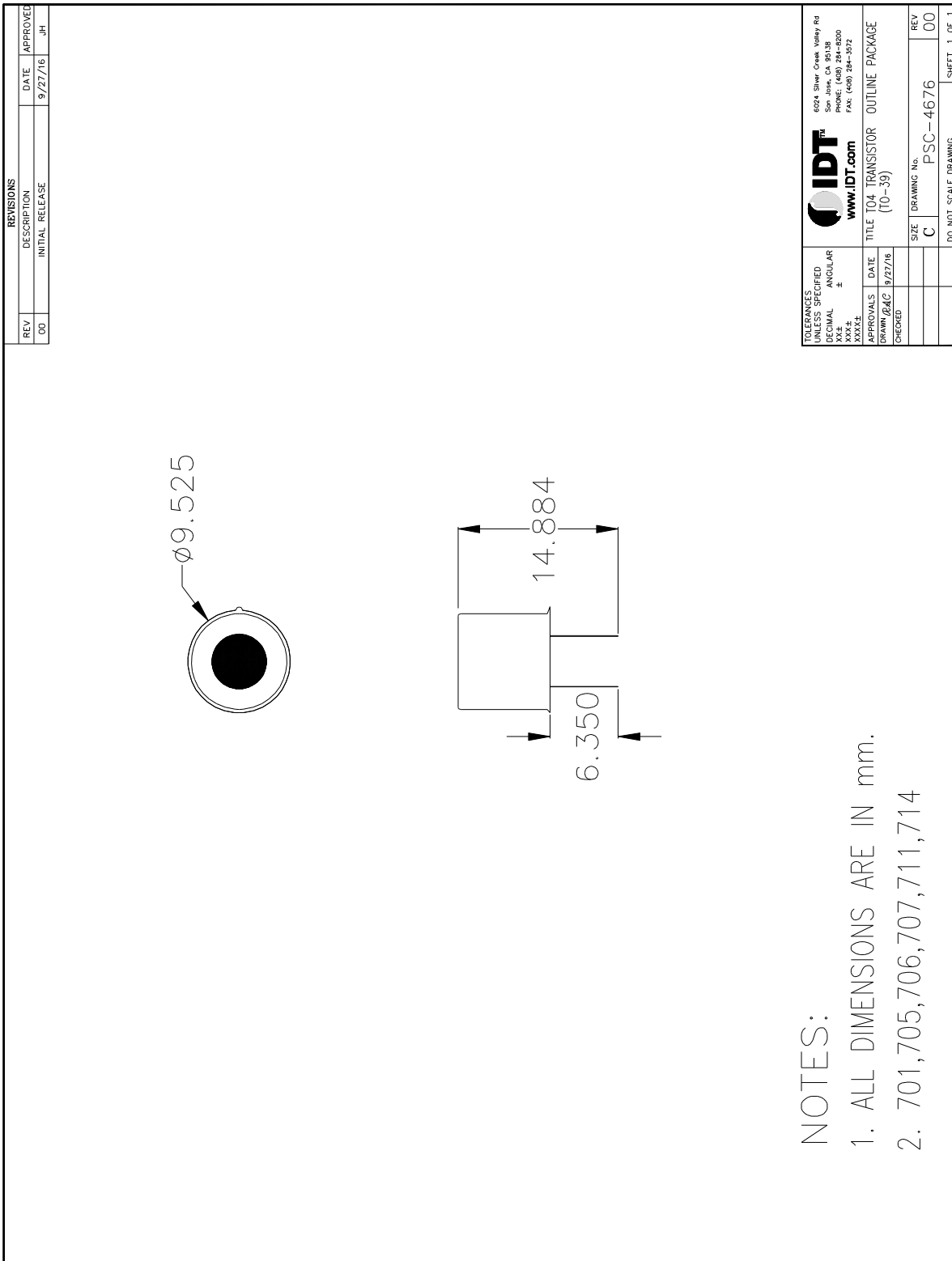

11. Applications and Use Conditions

The SGAS701 sensor is designed for gas leak detection and measurement of ppm levels of hydrogen. The sensor is not intended, recommended, or approved for use in safety or life protecting applications or in potentially explosive environments. IDT disclaims all liability for such use.

12. Ordering Information

Orderable Part Number	Package	MSL Rating	Shipping Packaging	Temperature
SGAS701	4-pin TO-39 (TO4)	1	Tray	-20°C to 50°C
SMOD701KITV1	SMOD701 Evaluation Kit, including the SMOD701 Smart Sensing Module (includes the SGAS701 sensor), mini-USB cable, and wall-mounted 9V power supply. The <i>SMOD7xx Application Software</i> is available for download at www.idt.com/SMOD701 .			

13. Revision History

Revision Date	Description of Change
November 16, 2016	Minor correction.
October 25, 2017	Full revision.
November 9, 2016	Initial release with IDT branding.

IMPORTANT NOTICE AND DISCLAIMER

RENESAS ELECTRONICS CORPORATION AND ITS SUBSIDIARIES (“RENESAS”) PROVIDES TECHNICAL SPECIFICATIONS AND RELIABILITY DATA (INCLUDING DATASHEETS), DESIGN RESOURCES (INCLUDING REFERENCE DESIGNS), APPLICATION OR OTHER DESIGN ADVICE, WEB TOOLS, SAFETY INFORMATION, AND OTHER RESOURCES “AS IS” AND WITH ALL FAULTS, AND DISCLAIMS ALL WARRANTIES, EXPRESS OR IMPLIED, INCLUDING, WITHOUT LIMITATION, ANY IMPLIED WARRANTIES OF MERCHANTABILITY, FITNESS FOR A PARTICULAR PURPOSE, OR NON-INFRINGEMENT OF THIRD PARTY INTELLECTUAL PROPERTY RIGHTS.

These resources are intended for developers skilled in the art designing with Renesas products. You are solely responsible for (1) selecting the appropriate products for your application, (2) designing, validating, and testing your application, and (3) ensuring your application meets applicable standards, and any other safety, security, or other requirements. These resources are subject to change without notice. Renesas grants you permission to use these resources only for development of an application that uses Renesas products. Other reproduction or use of these resources is strictly prohibited. No license is granted to any other Renesas intellectual property or to any third party intellectual property. Renesas disclaims responsibility for, and you will fully indemnify Renesas and its representatives against, any claims, damages, costs, losses, or liabilities arising out of your use of these resources. Renesas' products are provided only subject to Renesas' Terms and Conditions of Sale or other applicable terms agreed to in writing. No use of any Renesas resources expands or otherwise alters any applicable warranties or warranty disclaimers for these products.

(Disclaimer Rev.1.0 Mar 2020)

Corporate Headquarters

TOYOSU FORESIA, 3-2-24 Toyosu,
Koto-ku, Tokyo 135-0061, Japan
www.renesas.com

Contact Information

For further information on a product, technology, the most up-to-date version of a document, or your nearest sales office, please visit:
www.renesas.com/contact/

Trademarks

Renesas and the Renesas logo are trademarks of Renesas Electronics Corporation. All trademarks and registered trademarks are the property of their respective owners.