

# RF POWER MOSFETS

## N-CHANNEL ENHANCEMENT MODE

**125V 100W 100MHz**

The ARF463AP1 and ARF463BP1 comprise a symmetric pair of common source RF power transistors designed for push-pull scientific, commercial, medical and industrial RF power amplifier applications up to 100MHz. They have been optimized for both linear and high efficiency classes of operation.

- Specified 125 Volt, 81.36MHz Characteristics:
  - Output Power = 100 Watts.
  - Gain = 15dB (Class AB)
  - Efficiency = 75% (Class C)
- Low Cost Common Source RF Package.
  - Low  $V_{th}$  thermal coefficient.
  - Low Thermal Resistance.
  - Optimized SOA for Superior Ruggedness.

### MAXIMUM RATINGS

 All Ratings:  $T_C = 25^\circ\text{C}$  unless otherwise specified.

Symbol	Parameter	ARF463A_BP1(G)	UNIT
$V_{DSS}$	Drain-Source Voltage	500	Volts
$V_{DGO}$	Drain-Gate Voltage	500	
$I_D$	Continuous Drain Current @ $T_C = 25^\circ\text{C}$	9	Amps
$V_{GS}$	Gate-Source Voltage	$\pm 30$	Volts
$P_D$	Total Power Dissipation @ $T_C = 25^\circ\text{C}$	180	Watts
$R_{\theta JC}$	Junction to Case	0.70	$^\circ\text{C}/\text{W}$
$T_J, T_{STG}$	Operating and Storage Junction Temperature Range	-55 to 150	$^\circ\text{C}$
$T_L$	Lead Temperature: 0.063" from Case for 10 Sec.	300	

### STATIC ELECTRICAL CHARACTERISTICS

Symbol	Characteristic / Test Conditions	MIN	TYP	MAX	UNIT
$BV_{DSS}$	Drain-Source Breakdown Voltage ( $V_{GS} = 0\text{V}, I_D = 250 \mu\text{A}$ )	500			Volts
$V_{DS(ON)}$	On State Drain Voltage <sup>①</sup> ( $I_D(ON) = 4.5\text{A}, V_{GS} = 10\text{V}$ )			5.0	
$I_{DSS}$	Zero Gate Voltage Drain Current ( $V_{DS} = V_{DSS}, V_{GS} = 0\text{V}$ )			25	$\mu\text{A}$
	Zero Gate Voltage Drain Current ( $V_{DS} = 0.8 V_{DSS}, V_{GS} = 0\text{V}, T_C = 125^\circ\text{C}$ )			250	
$I_{GSS}$	Gate-Source Leakage Current ( $V_{GS} = \pm 30\text{V}, V_{DS} = 0\text{V}$ )			$\pm 100$	nA
$g_{fs}$	Forward Transconductance ( $V_{DS} = 25\text{V}, I_D = 4.5\text{A}$ )	2	3	4	mhos
$V_{GS(TH)}$	Gate Threshold Voltage ( $V_{DS} = V_{GS}, I_D = 50\text{mA}$ )	3		5	Volts

 **CAUTION:** These Devices are Sensitive to Electrostatic Discharge. Proper Handling Procedures Should Be Followed.

**DYNAMIC CHARACTERISTICS**

**ARF463A\_BP1(G)**

Symbol	Characteristic	Test Conditions	MIN	TYP	MAX	UNIT
$C_{iss}$	Input Capacitance	$V_{GS} = 0V$ $V_{DS} = 50V$ $f = 1\text{ MHz}$		670		pF
$C_{oss}$	Output Capacitance			120		
$C_{rss}$	Reverse Transfer Capacitance			50		
$t_{d(on)}$	Turn-on Delay Time	$V_{GS} = 15V$ $V_{DD} = 0.5 V_{DSS}$ $I_D = I_{D[Cont.]} @ 25^\circ C$ $R_G = 1.6\Omega$		5.6		ns
$t_r$	Rise Time			4.3		
$t_{d(off)}$	Turn-off Delay Time			13.5		
$t_f$	Fall Time			4.2		

**FUNCTIONAL CHARACTERISTICS**

Symbol	Characteristic	Test Conditions	MIN	TYP	MAX	UNIT
$G_{PS}$	Common Source Amplifier Power Gain	$f = 81.36\text{ MHz}$	13	15		dB
$\eta$	Drain Efficiency	$V_{GS} = 0V$ $V_{DD} = 125V$	70	75		%
$\psi$	Electrical Ruggedness VSWR 10:1	$P_{out} = 100W$	No Degradation in Output Power			

① Pulse Test: Pulse width < 380  $\mu$ S, Duty Cycle < 2%

APT Reserves the right to change, without notice, the specifications and information contained herein.

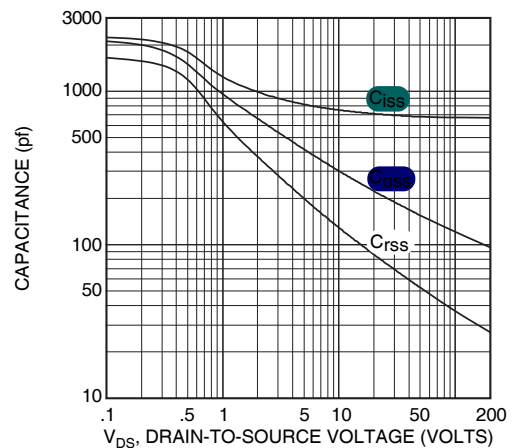

Figure 2, Typical Capacitance vs. Drain-to-Source Voltage

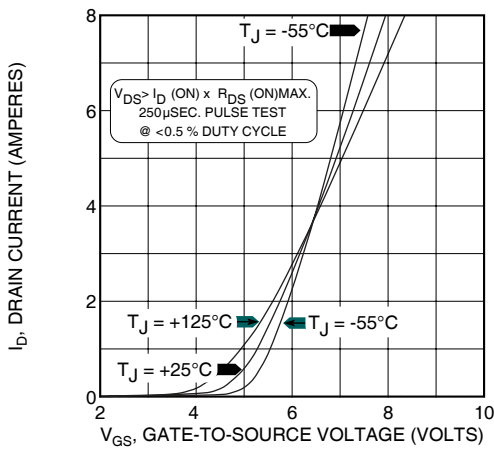

Figure 3, Typical Transfer Characteristics

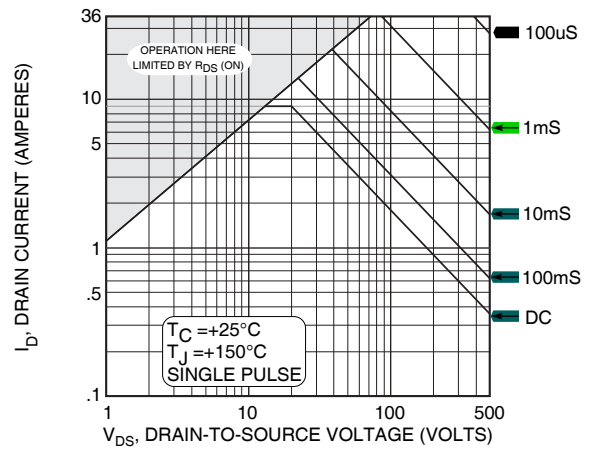

Figure 4, Typical Maximum Safe Operating Area

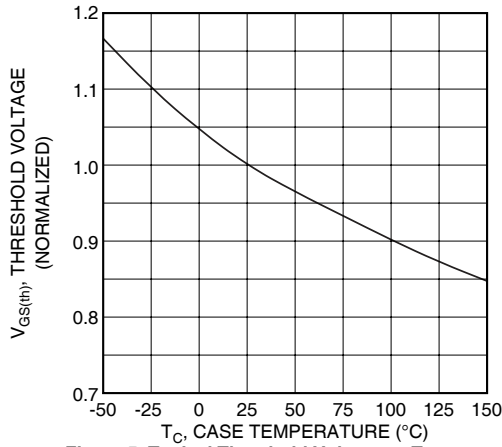

Figure 5, Typical Threshold Voltage vs Temperature

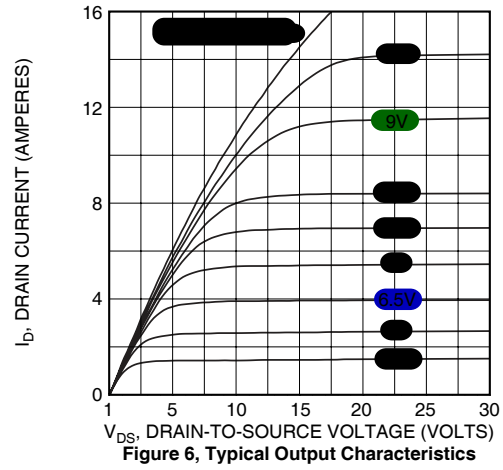

Figure 6, Typical Output Characteristics

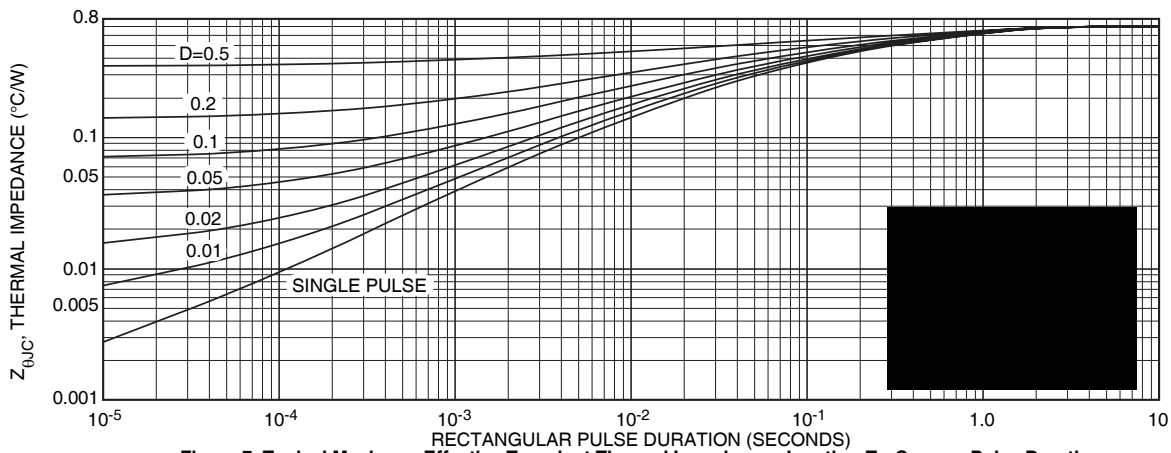
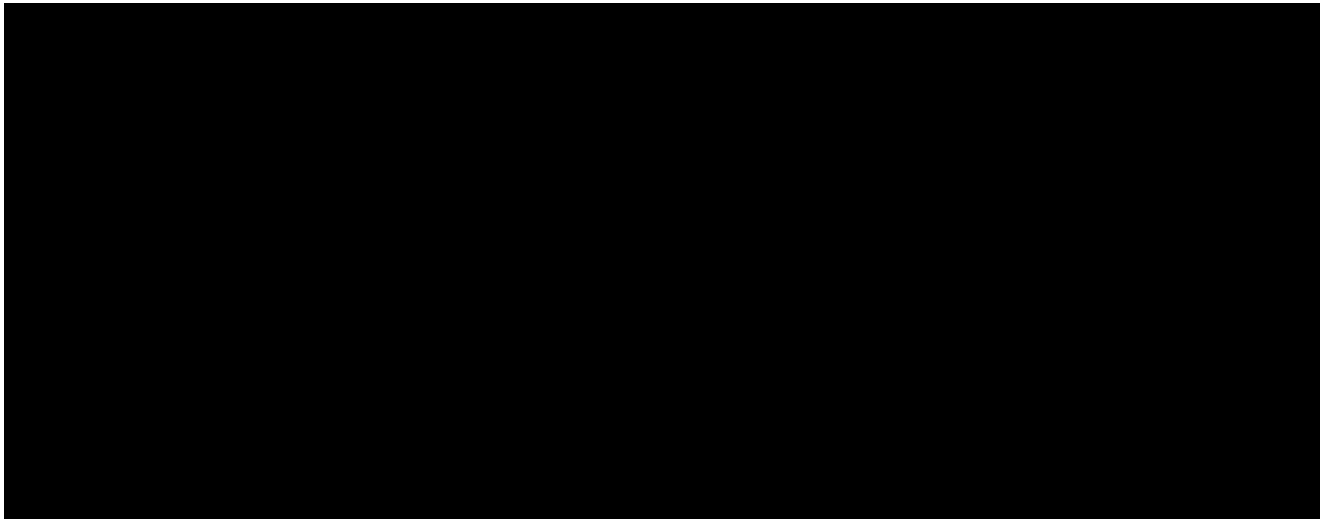

Figure 7, Typical Maximum Effective Transient Thermal Impedance, Junction-To-Case vs Pulse Duration

Table 1 - Typical Class AB Large Signal Input - Output Impedance

Freq. (MHz)	Z <sub>in</sub> (Ω)	Z <sub>OL</sub> (Ω)
2.0	24 - j 5.0	55 - j 4.8
13.5	7.8 - j 11	41 - j 24
27	2.1 - j 6.4	23 - j 26.2
40	.74 - j 3.3	13.6 - j 22
65	.30 + j .42	6.1 - j 14.2
80	.46 + j 2.0	4.2 - j 10.7
100	.87 + j 3.7	2.7 - j 7.1

Z<sub>in</sub> - Gate shunted with 25Ω

I<sub>DQ</sub> = 50mA

Z<sub>OL</sub> - Conjugate of optimum load for 100 Watts output at V<sub>DD</sub> = 125V

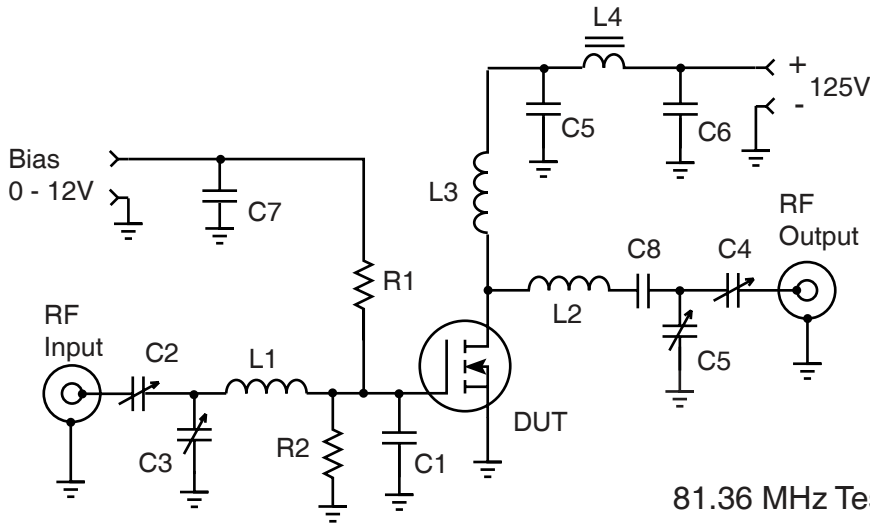

- C1 -- 820pF Unelco mounted at gate lead
- C2-C5 -- Arco 463 Mica trimmer
- C5-C8 -- 10nF 500V COG chip
- L1 -- 3t #18 .3" ID .25"L ~50nH
- L2 -- 3t #16 AWG .25" ID .3"L ~58nH
- L3 -- 10t #18 AWG .25 ID ~470nH
- L4 -- VK200-4B ferrite choke ~3uH
- R1-R2 -- 50 Ohm 1/2W Carbon
- DUT = ARF463A/B

81.36 MHz Test Circuit

**TO-247 Package Outline**

Ⓜ3 100% Sn Plated

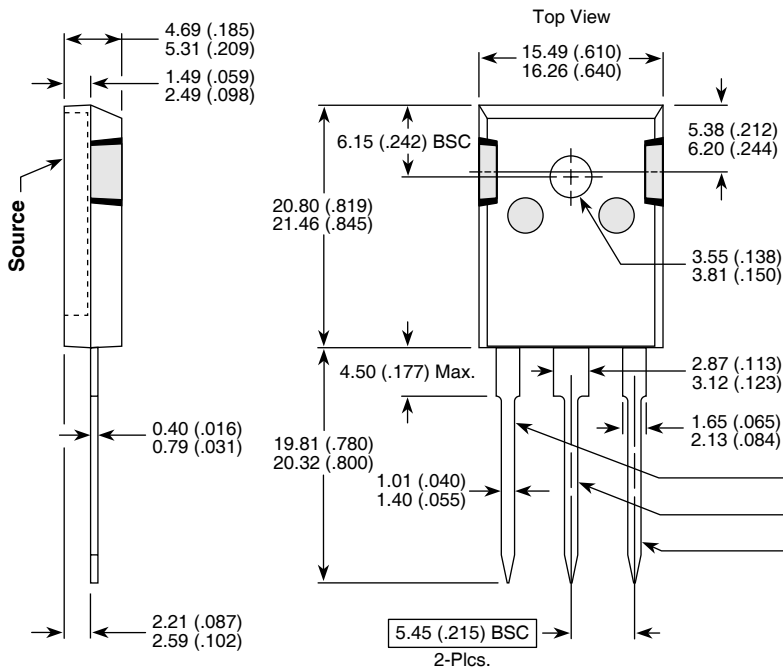

Dimensions in Millimeters and (Inches)  
**NOTE:** These two parts comprise a symmetric pair of RF power transistors and meet the same electrical specifications. The device pin-outs are the mirror image of each other to allow ease of use as a push-pull pair.

Device	
ARF - AP1	ARF - BP1
Gate	Drain
Source	Source
Drain	Gate