

Product Document



**high
performance
needs great
design.**

AS1105 Serially interfaced 4-digit LED driver datasheet

Please be patient while we update our brand image as austriamicrosystems and TAOS are now ams.

AS1105

Serially Interfaced, 4-Digit LED Driver

1 General Description

The AS1105 is an LED driver for 7-segment numeric displays of up to 4 digits. The AS1105 can be programmed via a conventional 4-wire serial interface.

The device includes a BCD code-B decoder, a multiplex scan circuitry, segment and display drivers, and a 32-bit memory. The memory is used to store the LED settings, so that continuous reprogramming is not necessary.

Every individual segment can be addressed and updated separately. Only one external resistor is required to set the current through the LED display.

Brightness can be controlled either in an analog or digital way. The user can choose the internal code-B decoder to display numeric digits or to address each segment directly.

The AS1105 features an extremely low shutdown current of only 20µA and an operational current of less than 500µA. The number of visible digits can be programmed as well.

The AS1105 can be reset by software and an external clock can be used. Several test modes support easy debugging.

AS1105 is offered in a 20-pin SOIC package.

2 Key Features

- Cost effective version of AS1100 functionality for applications up to 4-Digits
- 10MHz Serial Interface
- Individual LED Segment Control
- Decode/No-Decode Digit Selection
- 20µA Low-Power Shutdown (Data Retained)
- Extremely low Operating Current 0.5mA in open loop
- Digital and Analog Brightness Control
- Display Blanked on Power-Up
- Drive Common-Cathode LED Display
- Software Reset
- Optional External clock
- 20-pin SOIC Package

3 Applications

The AS1105 is an ideal solution for Bar-Graph Displays, Industrial Controllers, Panel Meters, LED Matrix Displays and White Goods such as washing machines, dishwasher, etc.

Figure 1. AS1105 - Typical Application Circuit

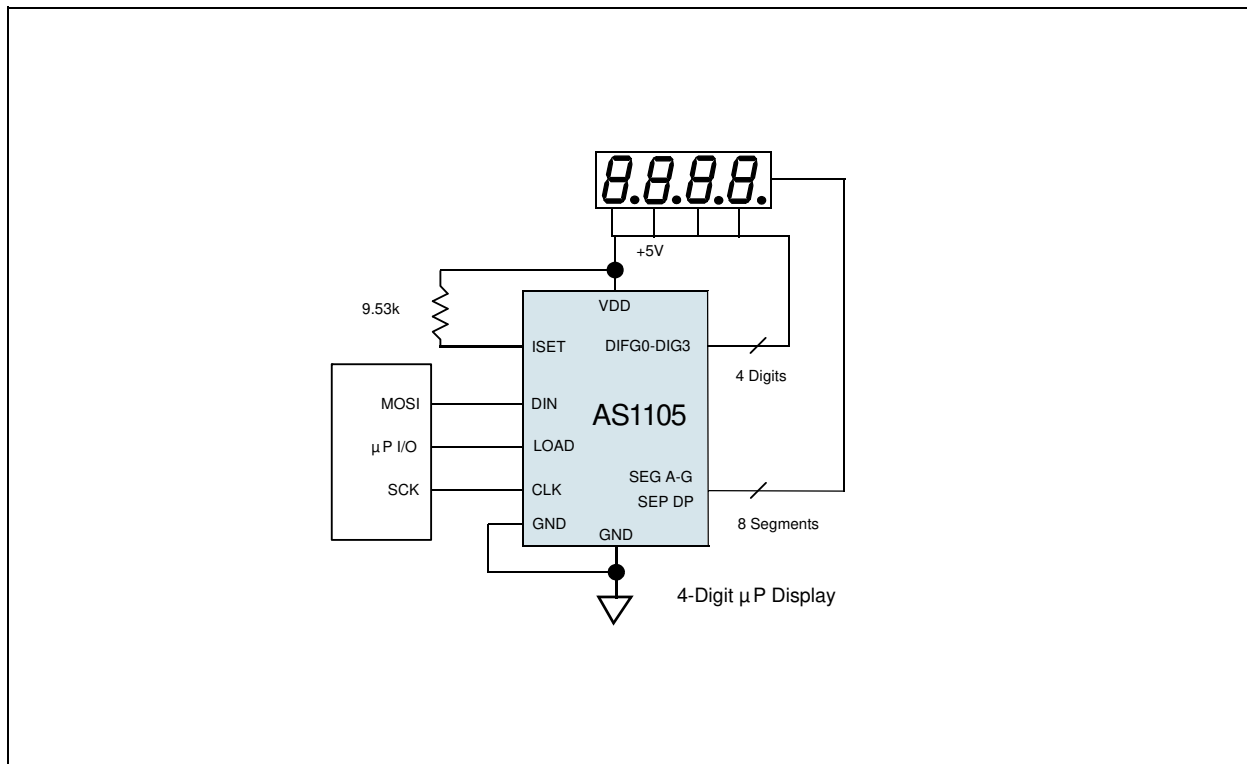



4 Pin Assignments

Figure 2. Pin Configuration (Top View)

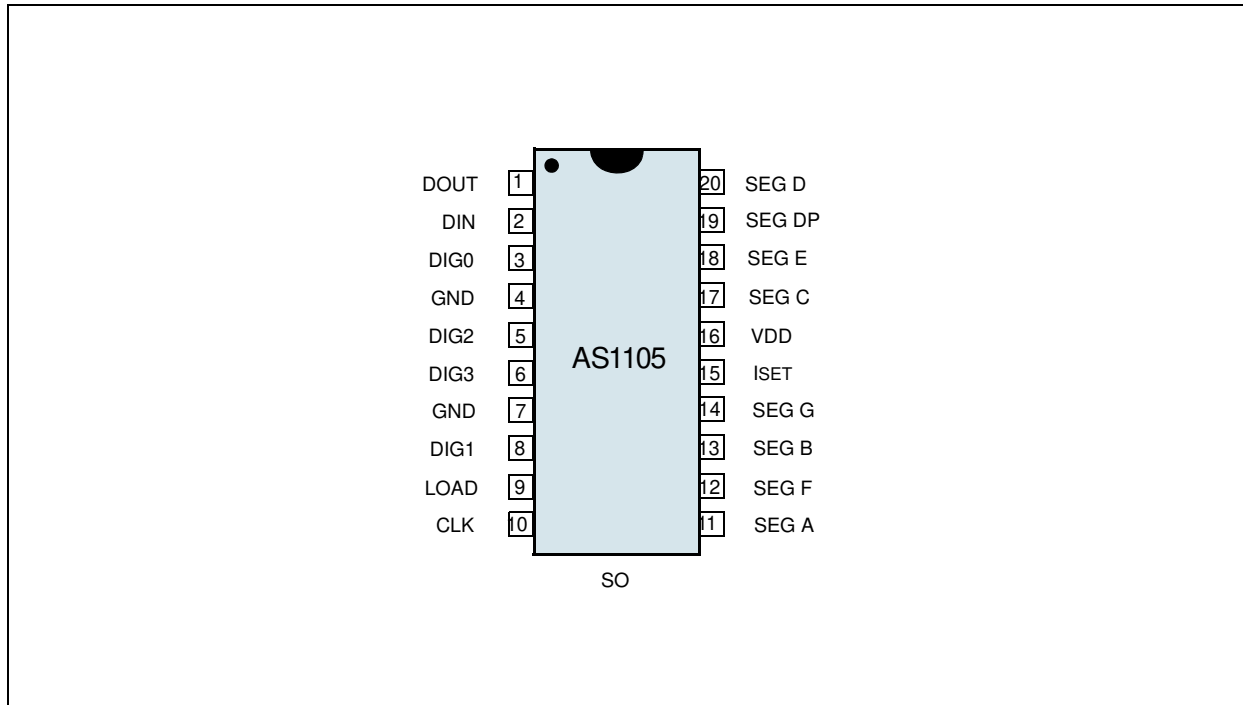

4.1 Pin Descriptions

Table 1. Pin Descriptions

Pin Number	Pin Name	Description
1	DOUT	Serial data output for cascading drivers. The output is valid after 16.5 clock cycles. The output is never set to high impedance.
2	DIN	Data input. Data is programmed into the 16-bit shift register on the rising CLK edge.
3,8,5,6	DIG0 : DIG3	4-digit driver lines that sink the current from the common cathode of the display. In shutdown mode the AS1105 switches the outputs to VDD.
4,7	GND	Both GND pins must be connected.
9	LOAD	Strobe input. With the rising edge of the LOAD signal the 16-bit of serial data is latched into the register.
10	CLK	Clock input. The interface is capable to support clock frequencies up to 10MHz. The serial data is clocked into the internal shift register with the rising edge of the CLK signal. On the DOUT pin the data is applied with the falling edge of CLK.
11:14, 17:20	SEGA:G, DP	Seven segment driver lines including the decimal point. When a segment is turned off the output is connected to GND.
15	ISET	The current into I _{SET} determines the peak current through the segments and therefore the brightness.
16	VDD	Positive Supply Voltage (+5V)



5 Absolute Maximum Ratings

Table 2. Absolute Maximum Ratings

Parameter	Min	Max	Units	Notes
VDD to GND	-0.3	+6	V	
DIN, CLK, LOAD to GND	-0.3	+6	V	
All Other pins to GND	-0.3	VDD + 0.3	V	
Current				
DIG0–DIG3 Sink Current	500		mA	
SEGA–G, DP Source Current	100		mA	
Continuous Power Dissipation (TA = +85°C)				
Wide SO	941		mW	Derate 11.8mW/°C above +70°C
Operating Temperature Range	-40	+85	°C	
Storage Temperature Range	-65	+150	°C	
Package body temperature		+260	°C	The reflow peak soldering temperature (body temperature) is specified according IPC/JEDEC J-STD-020D "Moisture/Reflow Sensitivity Classification for non-hermetic Solid State Surface Mount Devices".
Moisture Sensitivity Level	3			Represents a maximum floor life of 168h



6 Electrical Characteristics

VDD = 5V, RSET = 9.53kΩ ± 1%, T_A = T_{MIN} to T_{MAX}, unless otherwise noted.

Table 3. Electrical Characteristics

Symbol	Parameter	Conditions	Min	Typ	Max	Units
VDD	Operating Supply Voltage		4.0	5.0	5.5	V
IDDS	Shutdown Supply Current	All digital inputs at VDD or GND, T _A = +25°C		20	50	μA
IDD	Operating Supply Current	RSET = open circuit			500	μA
		All segments and decimal point on, I _{SEG} = -40mA		330		mA
fOSC	Display Scan Rate		500	800	1300	Hz
IDIGIT	Digit Drive Sink Current	VOUT = 0.65V	320			mA
I _{SEG}	Segment Drive Source Current	T _A = +25°C, VOUT = (VDD - 1V)	-30	-40	-45	mA
ΔI _{SEG}	Segment Drive Current Matching			3.0		%
IDIGIT	Digit Drive Source Current	Digit off, VDIGIT = (VDD - 0.3V)	-2			mA
I _{SEG}	Segment Drive Sink Current	Segment off, VSEG = 0.3V	5			mA
Logic Inputs						
I _{IH} , I _{IL}	Input Current DIN, CLK, LOAD	VIN = 0V or VDD	-1		1	μA
V _{IH}	Logic High Input Voltage		3.5			V
V _{IL}	Logic Low Input Voltage				0.8	V
V _{OH}	Output High Voltage	DOUT, ISOURCE = -1mA	VDD - 1			V
V _{OL}	Output Low Voltage	DOUT, ISINK = 1.6mA			0.4	V
	Hysteresis Voltage	DIN, CLK, LOAD		1		V
Timing Characteristics						
t _{CP}	CLK Clock Period		100			ns
t _{CH}	CLK Pulse Width High		50			ns
t _{CL}	CLK Pulse Width Low		50			ns
t _{CSH}	CLK Rise to LOAD Rise Hold Time		0			ns
t _{DS}	DIN Setup Time		25			ns
t _{DH}	DIN Hold Time		0			ns
t _{DO}	Output Data Propagation Delay	C _{LOAD} = 50pF			25	ns
t _{LDCK}	LOAD Rising Edge to Next Clock Rising Edge		50			ns
t _{CSW}	Minimum LOAD Pulse High		50			ns
t _{DSPD}	Data-to-Segment Delay				2.25	ms



7 Typical Operating Characteristics

Figure 3. Segment Driver Capability,
VDD = 5V, Logic Level = High

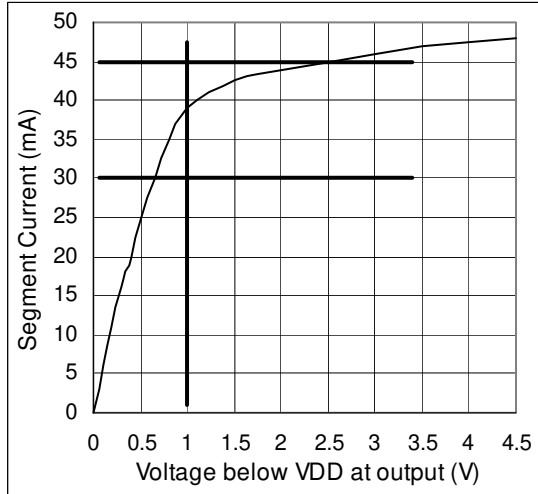
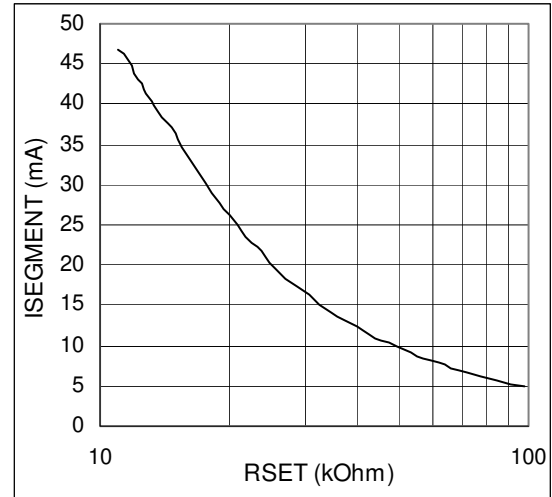

Figure 4. Segment Current versus RSET





8 Detailed Description

8.1 Serial-Addressing Modes

The programming of the AS1105 is done via the 4-wire serial interface. A programming sequence consists of 16-bit packages. The data is shifted into the internal 16-Bit register with the rising edge of the CLK signal. With the rising edge of the LOAD signal, the data is latched into a digital or control register depending on the address. The LOAD signal must go to high after the 16th rising clock edge. The LOAD signal can also come later but just before the next rising edge of CLK, otherwise data would be lost. The content of the internal shift register is applied 16.5 clock cycles later to the DOUT pin. The data is clocked out at the falling edge of CLK. The Bits of the 16Bit-programming package are described in Table 4. The first 4 Bits D15-D12 are "don't care, D11-D8 contain the address and D7-D0 contain the data. The first bit is D15, the most significant bit (MSB). The exact timing is given in Figure 5.

Figure 5. Timing Diagram

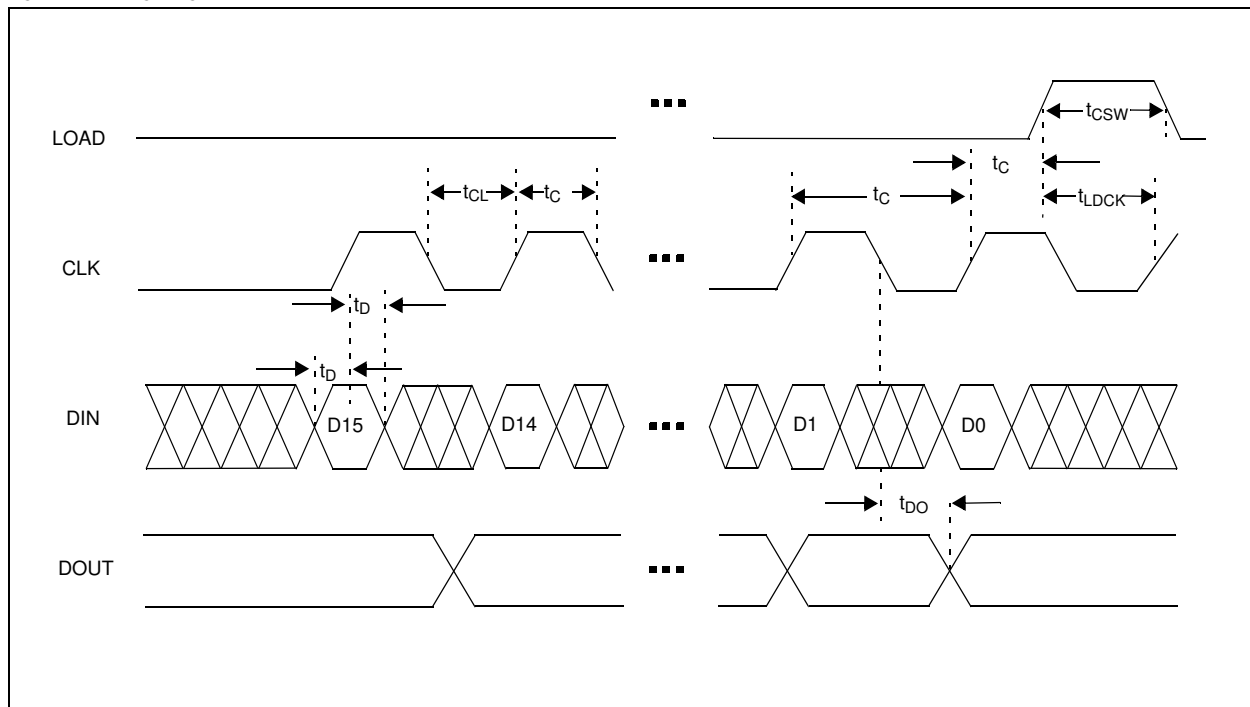

Table 4. Serial Data Format (16 Bits)

D15	D14	D13	D12	D11	D10	D9	D8	D7	D6	D5	D4	D3	D2	D1	D0
X	X	X	X	Address				MSB	Data				LSB		

8.2 Digit and Control Registers

The AS1105 incorporates 12 registers, which are listed in Table 5. The digit and control registers are selected via the 4Bit address word. The 4 digit registers are realized with a 32bit memory. Each digit can be controlled directly without rewriting the whole contents. The control registers consist of decode mode, display intensity, number of scanned digits, shutdown, display test and reset/external clock register.

8.3 Shutdown Mode

The AS1105 features a shutdown mode, where it consumes only 20 μ A current. The shutdown mode is entered via a write to register 0Ch. Then all segment current sources are pulled to ground and all digit drivers are connected to VDD, so that nothing is displayed. All internal digit registers keep the programmed values. The shutdown mode can either be used for power saving or for generating a flashing display by repeatedly entering and leaving the shutdown mode. The AS1105 needs typically 250 μ s to exit the shutdown mode. During shutdown, the AS1105 is fully programmable. Only the display test function overrides the shutdown mode.



8.4 Initial Power-up

After powering up the system, all registers are reset, so that the display is blank. The AS1105 starts the shutdown mode. All registers should be programmed for normal operation. The default settings enable only scan of one digit, the internal decoder is disabled, data register and intensity register are set to the minimum value.

8.5 Decode-Mode Register

In the AS1105, a BCD decoder is included. Every digit can be selected via register 09h to be decoded. The BCD code consists of the numbers 0-9, E, H, L, P and -. In register 09h, a logic high enables the decoder for the appropriate digit. In case that the decoder is bypassed (logic low), the data Bits D7-D0 correspond to the segment lines of the AS1105. In [Table 7](#) some possible settings for register 09h are shown. Bit D7, which corresponds to the decimal point, is not affected by the settings of the decoder. Logic high means that the decimal point is displayed. In [Table 8](#) the font of the Code B decoder is shown. In [Table 10](#) the correspondence of the register to the appropriate segments of a 7 segment display is shown (see [Figure 6](#)).

8.6 Intensity Control and Interdigit Blanking

Brightness of the display can be controlled in an analog way by changing the external resistor (RSET). The current, which flows between VDD and I_{SET}, defines the current that flows through the LEDs. The LED current is 100 times the I_{SET} current. The minimum value of RSET should be 9.53kΩ, which corresponds to 40mA segment current. The brightness of the display can also be controlled digitally via register 0Ah. The brightness can be programmed in 16 steps and is shown in [Table 10](#). An internal pulse width modulator controls the intensity of the display.

8.7 Scan-Limit Register

The scan limit register 0Bh selects the number of digits displayed. When all 4 digits are displayed the update frequency is typically 800Hz. If the number of digits displayed is reduced, the update frequency is reduced as well. The frequency can be calculated using $8f_{OSC}/N$, where N is the number of digits. Since the number of displayed digits influences the brightness, the resistor RSET should be adjusted accordingly. [Table 12](#) shows the maximum allowed current, when fewer than 4 digits are used. To avoid differences in brightness the scan limit register should not be used to blank portions of the display (leading zeros).

Table 5. Register Address Map

Register	Register					Hex Code
	D15-D12	D11	D10	D9	D8	
No-Op	X	0	0	0	0	0xX0
Digit 0	X	0	0	0	1	0xX1
Digit 1	X	0	0	1	0	0xX2
Digit 2	X	0	0	1	1	0xX3
Digit 3	X	0	1	0	0	0xX4
Decode Mode	X	1	0	0	1	0xX9
Intensity	X	1	0	1	0	0xXA
Scan Limit	X	1	0	1	1	0xXB
Shutdown	X	1	1	0	0	0xXC
Not used	X	1	1	0	1	0xXD
Reset and ext. Clock	X	1	1	1	0	0xXE
Display Test	X	1	1	1	1	0xXF



Table 6. Shutdown Register Format (address (hex) = 0xXC)

Mode	Address Code (Hex)	Register Data							
		D7	D6	D5	D4	D3	D2	D1	D0
Shutdown Mode	0xXC	X	X	X	X	X	X	X	0
Normal Operation	0xXC	X	X	X	X	X	X	X	1

Table 7. Decode-mode Register Examples (address (hex) = 0xX9)

Decode Mode	Register Data								Hex Code
	D7	D6	D5	D4	D3	D2	D1	D0	
No decode for digits 4–0	0	0	0	0	0	0	0	0	0x00
Code B decode for digit 0 No decode for digits 4–1	0	0	0	0	0	0	0	1	0x01
Code B decode for digits 3–0	0	0	0	0	1	1	1	1	0x0F
Code B decode for digits 4–0	1	1	1	1	1	1	1	1	0xFF

Table 8. Code B Font

7-Segment Character	Register Data						On Segments = 1							
	D7	D6-D4	D3	D2	D1	D0	DP	A	B	C	D	E	F	G
0		X	0	0	0	0		1	1	1	1	1	1	0
1		X	0	0	0	1		0	1	1	0	0	0	0
2		X	0	0	1	0		1	1	0	1	1	0	1
3		X	0	0	1	1		1	1	1	1	0	0	1
4		X	0	1	0	0		0	1	1	0	0	1	1
5		X	0	1	0	1		1	0	1	1	0	1	1
6		X	0	1	1	0		1	0	1	1	1	1	1
7		X	0	1	1	1		1	1	1	0	0	0	0
8		X	1	0	0	0		1	1	1	1	1	1	1
9		X	1	0	0	1		1	1	1	1	0	1	1
--		X	1	0	1	0		0	0	0	0	0	0	1
E		X	1	0	1	1		1	0	0	1	1	1	1
H		X	1	1	0	0		0	1	1	0	1	1	1
L		X	1	1	0	1		0	0	0	1	1	1	0
P		X	1	1	1	0		1	1	0	0	1	1	1
blank		X	1	1	1	1		0	0	0	0	0	0	0

Note: In the above table, the decimal point (DP) is set by bit D7 = 1

Table 9. No-decode Mode Data Bits and Corresponding Segment Lines

Register Data								
	D7	D6	D5	D4	D3	D2	D1	D0
Corresponding Segment Line	DP	A	B	C	D	E	F	G



Figure 6. Standard 7-segment LED

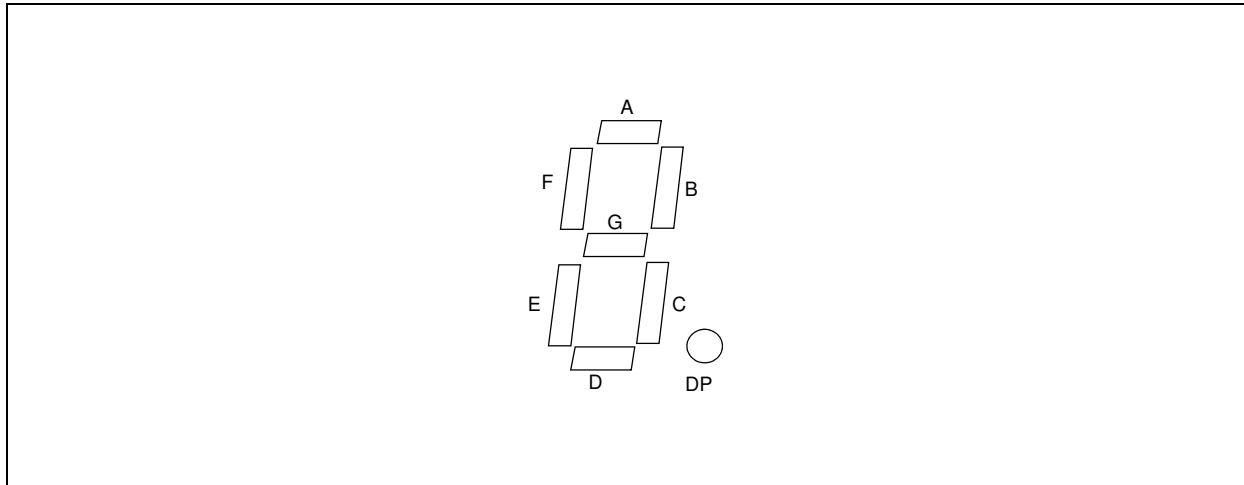

Table 10. Intensity Register Format (address (hex) = 0xA)

Duty Cycle	D7	D6	D5	D4	D3	D2	D1	D0	Hex Code
1/32 (min on)	X	X	X	X	0	0	0	0	0xX0
3/32	X	X	X	X	0	0	0	1	0xX1
5/32	X	X	X	X	0	0	1	0	0xX2
7/32	X	X	X	X	0	0	1	1	0xX3
9/32	X	X	X	X	0	1	0	0	0xX4
11/32	X	X	X	X	0	1	0	1	0xX5
13/32	X	X	X	X	0	1	1	0	0xX6
15/32	X	X	X	X	0	1	1	1	0xX7
17/32	X	X	X	X	1	0	0	0	0xX8
19/32	X	X	X	X	1	0	0	1	0xX9
21/32	X	X	X	X	1	0	1	0	0xXA
23/32	X	X	X	X	1	0	1	1	0xXB
25/32	X	X	X	X	1	1	0	0	0xXC
27/32	X	X	X	X	1	1	0	1	0xXD
29/32	X	X	X	X	1	1	1	0	0xXE
31/32 (max on)	X	X	X	X	1	1	1	1	0xFF

Table 11. Scan-limit Register Format (address (hex) = 0xB)

Scan Limit	Register Data								Hex Code
	D7	D6	D5	D4	D3	D2	D1	D0	
Display digit 0 only	X	X	X	X	X	0	0	0	0xX0
Display digits 0 & 1	X	X	X	X	X	0	0	1	0xX1
Display digits 0 1 2	X	X	X	X	X	0	1	0	0xX2
Display digits 0 1 2 3	X	X	X	X	X	0	1	1	0xX3



8.8 Display Test Register

With the display test register 0Fh all LED can be tested. In the test mode all LEDs are switched on at maximum brightness (duty cycle 31/32). All programming of digit and control registers is maintained. The format of the register is given in Table 13.

Table 12. Maximum Segment Current for 1-, 2-, or 3-digit Displays

Number of Digits Displayed	Maximum Segment Current (mA)
1	10
2	20
3	30

Table 13. Display-test Register Format (address (hex) = 0xXF)

Mode	Register Data							
	D7	D6	D5	D4	D3	D2	D1	D0
Normal Operation	X	X	X	X	X	X	X	0
Display Test Mode	X	X	X	X	X	X	X	1

Note: The AS1105 remains in display-test mode until the display-test register is reconfigured for normal operation.

8.9 No-Op Register (Cascading of AS1105)

The no-operation register 00h is used when AS1105s are cascaded in order to support more than 4 digit displays. The cascading must be done in a way that all DOUT are connected to DIN of the following AS1105. The LOAD and CLK signals are connected to all devices. For a write operation for example to the fifth device the command must be followed by four no-operation commands. When the LOAD signal finally goes to high all shift registers are latched. The first four devices have got no-operation commands and only the fifth device sees the intended command and updates its register.

8.10 Reset and External Clock Register

This register is addressed via the serial interface. It allows to switch the device to external clock mode (If D0=1 the CLK pin of the serial interface operates as system clock input.) and to apply an external reset (D1). This brings all registers (except reg. E) to default state. For standard operation the register contents should be "00h".

Table 14. Reset and external Clock register (address (hex) = 0xXE)

Mode	Address Code (hex)	Register Data							
		D7	D6	D5	D4	D3	D2	D1	D0
Normal Operation, internal clock	0xXE	X	X	X	X	X	X	0	0
Normal Operation, external clock	0xXE	X	X	X	X	X	X	0	1
Reset state, internal clock	0xXE	X	X	X	X	X	X	1	0
Reset state, external clock	0xXE	X	X	X	X	X	X	1	1

Table 15. RSET vs. segment current and LED forward voltage

ISEG (mA)	VLED(V)				
	1.5	2.0	2.5	3.0	3.5
40	12.2kΩ	11.8kΩ	11.0kΩ	10.6kΩ	9.69kΩ
30	17.8kΩ	17.1kΩ	15.8kΩ	15.0kΩ	14.0kΩ
20	29.8kΩ	28.0kΩ	25.9kΩ	24.5kΩ	22.6kΩ
10	66.7kΩ	63.7kΩ	59.3kΩ	55.4kΩ	51.2kΩ



9 Application Information

9.1 Supply Bypassing and Wiring

In order to achieve optimal performance the AS1105 shall be placed very close to the LED display to minimize effects of electromagnetic interference and wiring inductance. Furthermore, it is recommended to connect a 10 μ F electrolytic and a 0.1 μ F ceramic capacitor between VDD and GND to avoid power supply ripple. Also, both GNDs must be connected to ground.

9.2 Selecting R_{SET} Resistor and Using External Drivers

The current through the segments is controlled via the external resistor R_{SET}. Segment current is about 100 times the current in I_{SET}. The right values for I_{SET} are given in Table 12. The maximum current the AS1105 can drive is 40mA. If higher currents are needed, external drivers must be used. In that case it is no longer necessary that the AS1105 drives high currents. A recommended value for R_{SET} is 47k Ω . In cases that the AS1105 only drives few digits Table 10 specifies the maximum currents and R_{SET} must be set accordingly. Refer to Absolute Maximum Ratings to calculate acceptable limits for ambient temperature, segment current, and the LED forward-voltage drop.

9.3 4x8 LED Dot Matrix Driver

The example in Figure 7 uses the AS1105 to drive a 4x8 LED dot matrix. The LED columns have common cathode and are connected to the DIG0-3 outputs. The rows are connected to the segment drivers. Each of the 32 LEDs can be addressed separately. The columns are selected via the digits as shown in Table 5. The decode mode register (0x9) has to be programmed to '00000000' as stated in Table 7. The single LEDs in a column can be addressed as stated in Table 10, where D0 corresponds to segment G and D7 to segment DP. For a multiple digit dot matrix several AS1105 have to be cascaded.

Figure 7. Application Example as LED Dot Matrix Driver

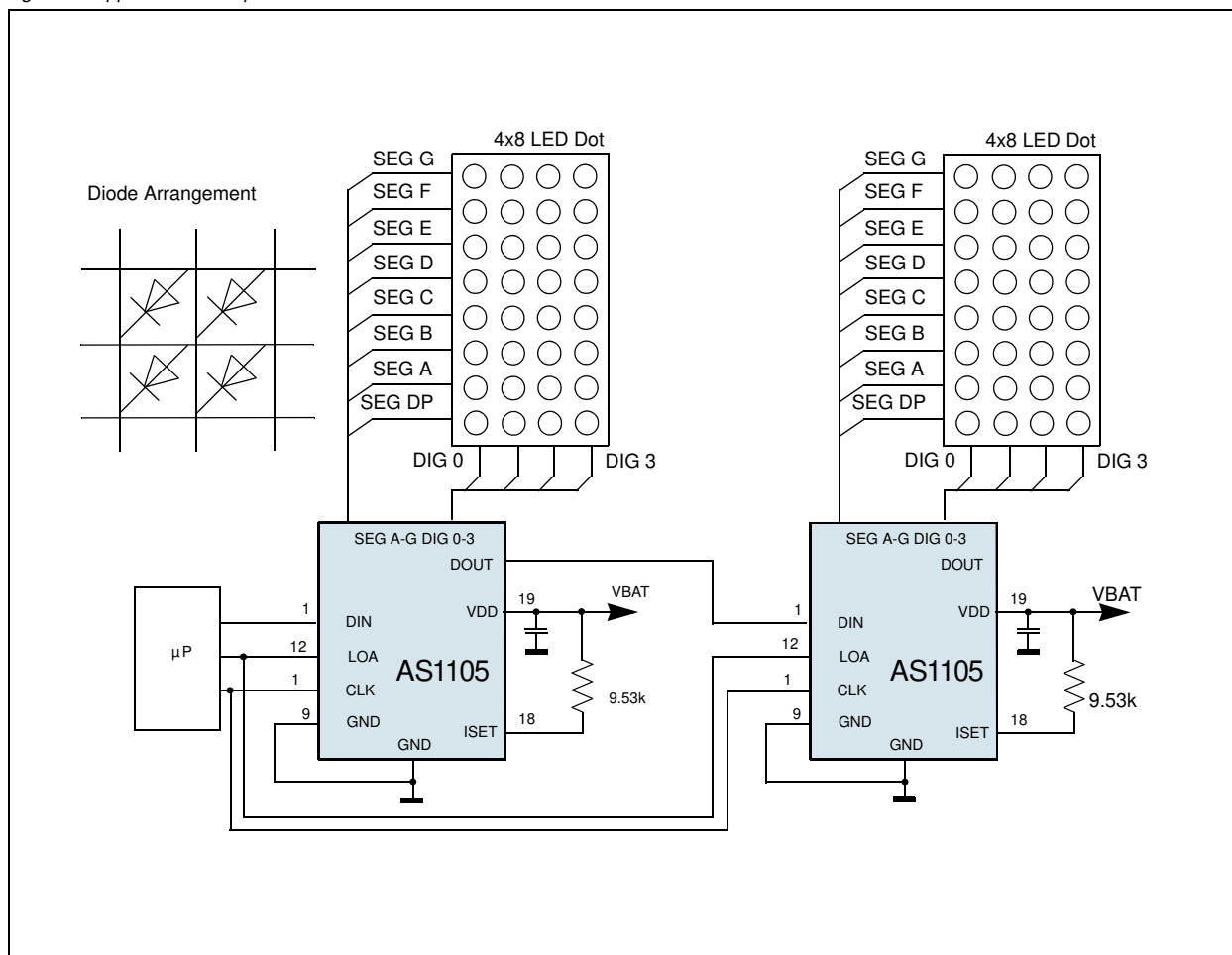



9.4 Cascading Drivers

The AS1105 can be cascaded as well. The DOUT pin must be connected to the DIN pin of the following AS1105.

Table 16. Package Thermal Resistance Data

Package	Thermal Resistance (θ_{JA})
20 Wide SO	+85°C/W
Maximum Junction Temperature (T _J) = +150°C	
Maximum Ambient Temperature (T _A) = +85°C	

9.5 Computing Power Dissipation

The upper limit for power dissipation (PD) for the AS1105 is determined from the following equation:

$$PD = (VDD \times 0.5mA) + (VDD - VLED)(DUTY \times I_{SEG} \times N) \quad (EQ 1)$$

Where:

VDD = supply voltage

DUTY = duty cycle set by intensity register

N = number of segments driven (worst case is 4)

VLED = LED forward voltage

I_{SEG} = segment current set by RSET

Dissipation Example:

I_{SEG} = 40mA, N = 4, DUTY = 31/32, VLED = 1.8V at 40mA, VDD = 5.25V

PD = 5.25V(0.5mA) + (5.25V - 1.8V)(31/32 x 40mA x 4) = 0.54W

Thus, for a SO package θ_{JA} = +85°C/W (see Table 13), the maximum allowed ambient temperature T_A is given by:

$$T_{J,MAX} = T_A + PD \times \theta_{JA} = 150^\circ C = T_A + 0.54W \times 85^\circ C/W \quad (EQ 2)$$

Where: T_A = +104°C



10 Package Drawings and Markings

The device is available in a 20-pin SOIC package.

Figure 8. SOIC-20 Package Drawings & Dimensions

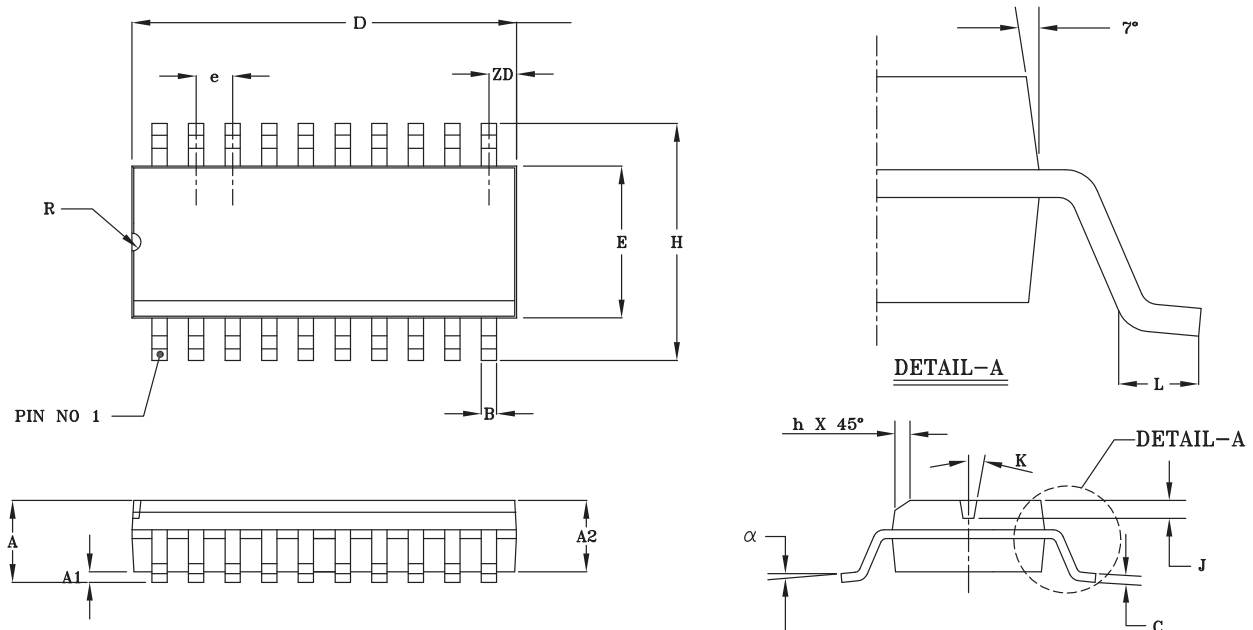

Symbol	Min	Max
A	2.44	2.64
A1	0.10	0.30
A2	2.24	2.44
B	0.36	0.46
C	0.23	0.32
D	12.65	12.85
E	7.40	7.60
e	1.27 BSC	

Symbol	Min	Max
H	10.11	10.51
h	0.31	0.71
J	0.53	0.73
K	7° BSC	
L	0.51	1.01
R	0.63	0.89
ZD	0.66 REF	
α	0°	8°



11 Ordering Information

The device is available as the standard products listed in [Table 17](#).

Table 17. Ordering Information

Part	Temp Range	Package	Delivery Form
AS1105WL	-40°C to +85°C	20-pin SOIC	Tubes
AS1105WL-T	-40°C to +85°C	20-pin SOIC	T&R

Note: All products are RoHS compliant.

Buy our products or get free samples online at www.ams.com/ICdirect

Technical Support is available at www.ams.com/Technical-Support

For further information and requests, email us at sales@ams.com

(or) find your local distributor at www.ams.com/distributor



Copyrights

Copyright © 1997-2012, ams AG, Tobelbaderstrasse 30, 8141 Unterpremstaetten, Austria-Europe. Trademarks Registered ®. All rights reserved. The material herein may not be reproduced, adapted, merged, translated, stored, or used without the prior written consent of the copyright owner.

All products and companies mentioned are trademarks or registered trademarks of their respective companies.

Disclaimer

Devices sold by ams AG are covered by the warranty and patent indemnification provisions appearing in its Term of Sale. ams AG makes no warranty, express, statutory, implied, or by description regarding the information set forth herein or regarding the freedom of the described devices from patent infringement. ams AG reserves the right to change specifications and prices at any time and without notice. Therefore, prior to designing this product into a system, it is necessary to check with ams AG for current information. This product is intended for use in normal commercial applications. Applications requiring extended temperature range, unusual environmental requirements, or high reliability applications, such as military, medical life-support or life-sustaining equipment are specifically not recommended without additional processing by ams AG for each application. For shipments of less than 100 parts the manufacturing flow might show deviations from the standard production flow, such as test flow or test location.

The information furnished here by ams AG is believed to be correct and accurate. However, ams AG shall not be liable to recipient or any third party for any damages, including but not limited to personal injury, property damage, loss of profits, loss of use, interruption of business or indirect, special, incidental or consequential damages, of any kind, in connection with or arising out of the furnishing, performance or use of the technical data herein. No obligation or liability to recipient or any third party shall arise or flow out of ams AG rendering of technical or other services.



Contact Information

Headquarters

ams AG
Tobelbaderstrasse 30
A-8141 Unterpremstaetten, Austria

Tel : +43 (0) 3136 500 0

Fax : +43 (0) 3136 525 01

For Sales Offices, Distributors and Representatives, please visit:

<http://www.ams.com/contact>