

LIN Transceiver

Features

- Supply Voltage up to 40V
- Operating Voltage $V_{VS} = 5V$ to 28V
- Very Low Supply Current
 - Sleep mode: Typically 9 μA
 - Fail-Safe mode: Typically 80 μA
 - Normal mode: Typically 250 μA
- Fully Compatible with 3.3V and 5V Devices
- LIN Physical Layer according to LIN 2.0, 2.1, 2.2, 2.2A and SAEJ2602-2
- Wake-Up Capability through LIN bus (100 μs Dominant)
- External Wake Up through WKin pin (100 μs Low Level)
- INH Output to Control an External Voltage Regulator or to Switch the Master Pull-Up
- Wake-Up Source Recognition
- TXD Time-Out Timer
- Bus Pin is Overtemperature and Short-Circuit Protected vs. GND and Battery
- Advanced EMC and ESD Performance
- Fulfills the OEM "Hardware Requirements for LIN in Automotive Applications Rev.1.3"
- Interference and Damage Protection according to ISO7637
- Qualified according to AEC-Q100
- Package: 8-Lead VDFN, 8-Lead SOIC, with Wettable Flanks (Moisture Sensitivity Level 1)

Description

The ATA663211 device is a fully integrated LIN transceiver designed in compliance with the LIN specification 2.0, 2.1, 2.2, 2.2A and SAEJ2602-2. It interfaces the LIN protocol handler and the physical layer. The device is designed to handle the low-speed data communication in convenience electronics, for example, in vehicles. Improved slope control at the LIN bus ensures data communication up to 20 Kbaud. Sleep mode guarantees minimal current consumption even in the case of a floating bus line or a short circuit on the LIN bus to GND.

Package Types

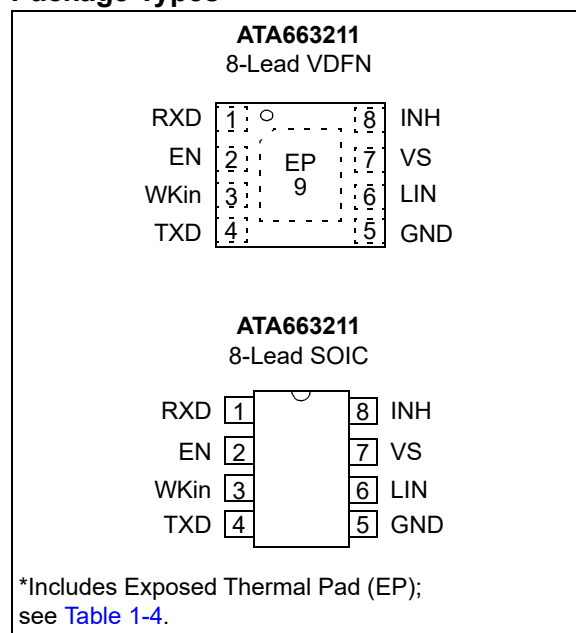

ATA663211

ATA663211 Block Diagram

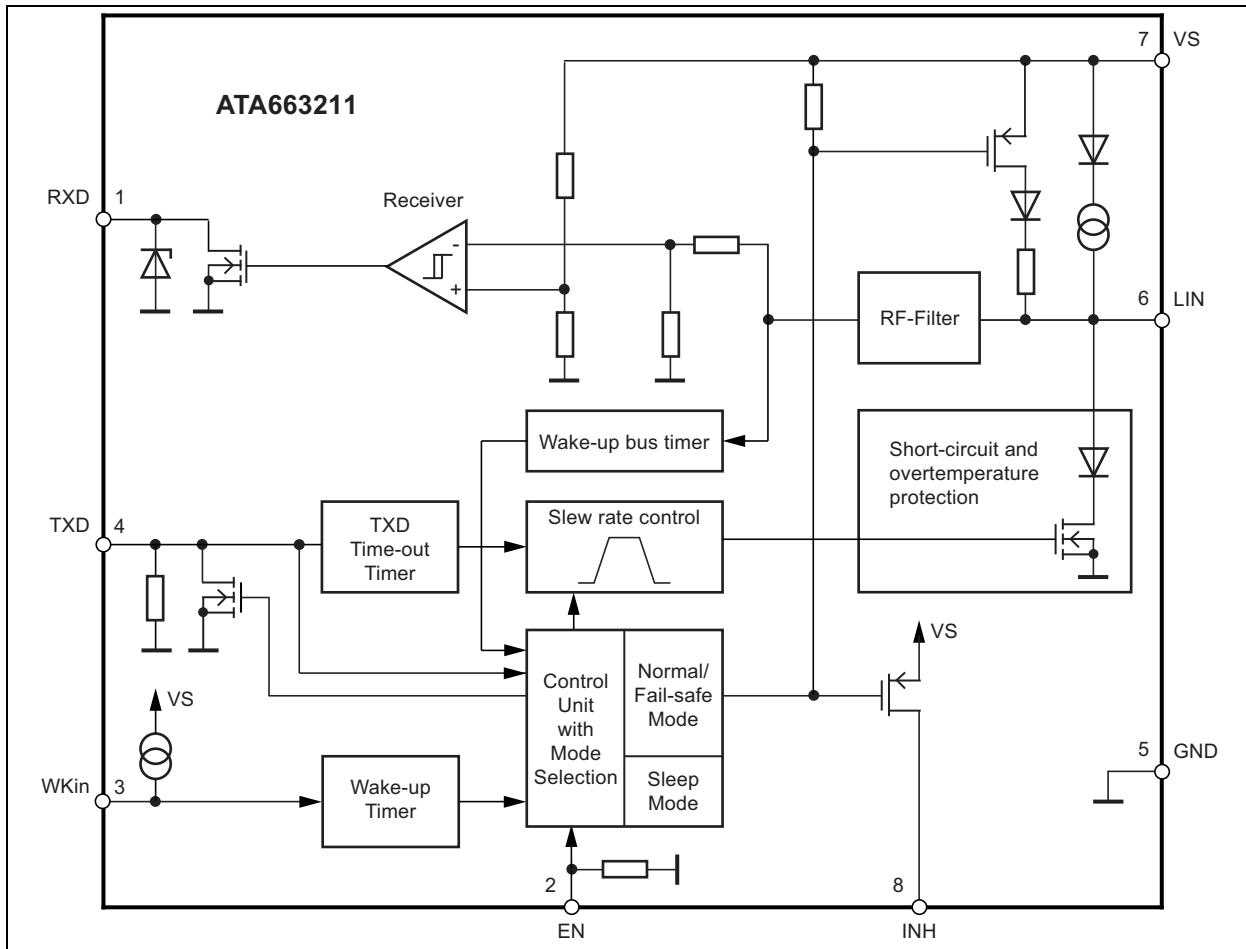

1.0 FUNCTIONAL DESCRIPTION

1.1 Physical Layer Compatibility

Since the LIN physical layer is independent of higher LIN layers (for example, LIN protocol layer), all nodes with a LIN physical layer according to revision 2.x can be mixed with LIN physical layer nodes based on earlier versions (for instance, LIN 1.0, LIN 1.1, LIN 1.2, LIN 1.3) without any restrictions.

1.2 Operating Modes

FIGURE 1-1: ATA663211 OPERATING MODES

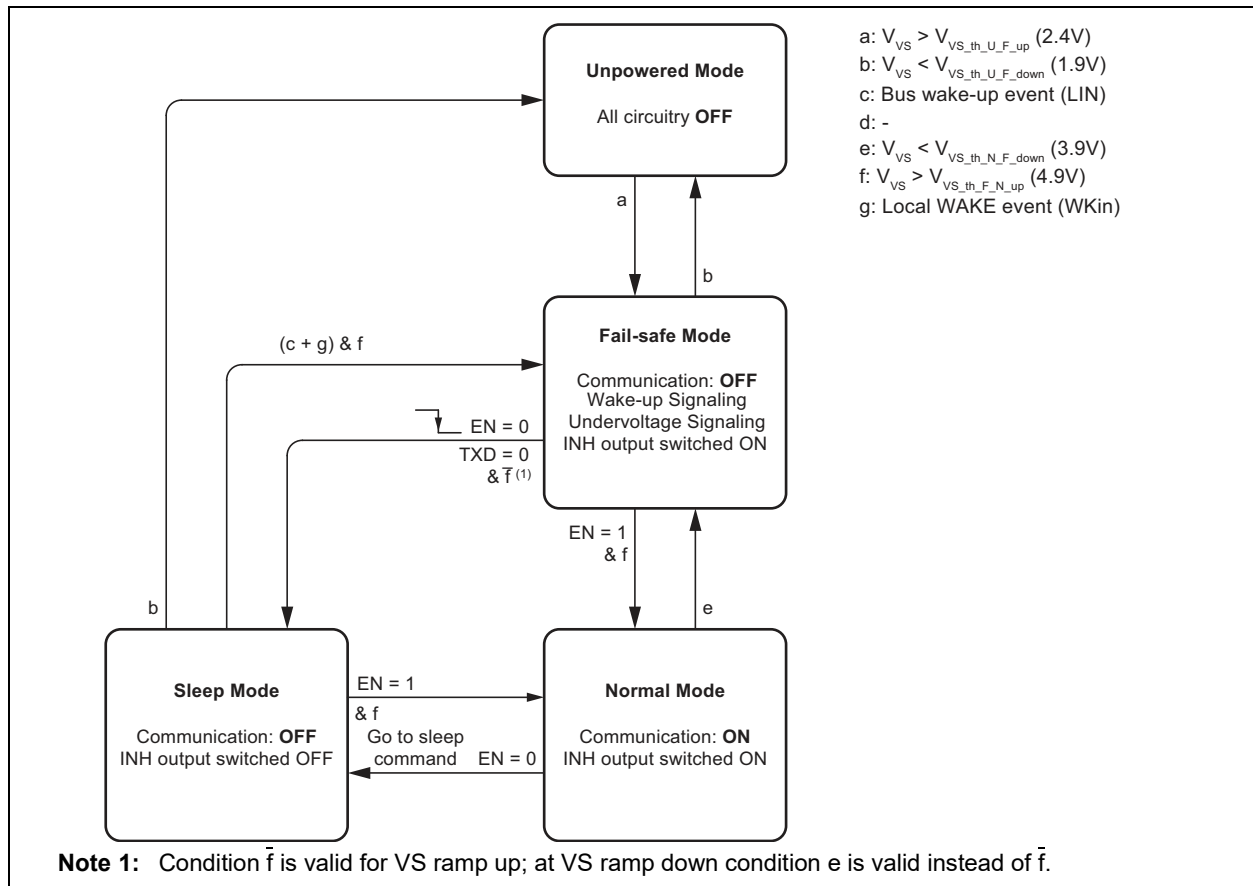

TABLE 1-1: ATA663211 OPERATING MODES

Operating Mode	Transceiver	INH	LIN	TXD	RXD
Fail-Safe	OFF	ON	Recessive	Signaling fail-safe sources (see Table 1-2)	
Normal	ON	ON	TXD-dependent	Follows data transmission	
Sleep/Unpowered	OFF	OFF	Recessive	Low	High Ohmic

ATA663211

1.2.1 NORMAL MODE

This is the normal transmitting and receiving mode of the LIN Interface, in accordance with LIN specification 2.x.

1.2.2 SLEEP MODE

A falling edge at EN switches the IC into Sleep mode. While in Sleep mode, the transmission path is disabled and the device is in Low-Power mode. Supply current from V_{BAT} is typically 9 μ A. In Sleep mode the INH pin is switched off. The internal termination between the LIN pin and VS pin is disabled. Only a weak pull-up current (typical 10 μ A) between the LIN pin and VS pin is present. Sleep mode can be activated independently from the actual level on the LIN or WKin pin.

If the TXD pin is short-circuited to GND, it is possible to switch to Sleep mode though EN after $t > t_{dom}$.

1.2.3 FAIL-SAFE MODE

The device automatically switches to Fail-Safe mode at system power-up or after a wake-up event. The INH output is switched on and the LIN transceiver is switched off. The IC stays in this mode until EN is switched to high. The IC then changes to Normal mode. During Fail-Safe mode the TXD pin is an output, and, together with the RXD output pin, signals the fail-safe source.

If the device enters Fail-Safe mode coming from the Normal mode (EN = 1) due to a VS undervoltage condition ($V_{VS} < V_{VS_th_N_F_down}$), it is possible to switch into Sleep mode by a falling edge at the EN input. With this feature, the current consumption is further reduced.

A wake-up event from Sleep mode is signaled to the microcontroller using the RXD pin and the TXD pin. A VS undervoltage condition is also signaled at these two pins. The coding is shown in [Table 1-2](#).

TABLE 1-2: SIGNALING IN FAIL-SAFE MODE

Fail-Safe Sources	TXD	RXD
LIN wake-up (LIN pin)	Low	Low
Local wake-up (WKin pin)	Low	High
$V_{S_{th}}$ (battery) undervoltage detection $V_{VS} < 3.9V$	High	Low

Note 1: Assuming an external pull-up resistor (typical 5 k Ω) has been added on pin TXD to the power supply of the microcontroller.

1.3 Wake-up Scenarios from Sleep Mode

1.3.1 REMOTE WAKE UP THROUGH LIN BUS

1.3.1.1 Remote Wake-up from Sleep Mode

A voltage lower than the LIN pre-wake detection VLINL at the LIN pin activates the internal LIN receiver and starts the wake-up detection timer. A falling edge at the LIN pin, followed by a dominant bus level maintained for a certain period of time ($>t_{bus}$) and following a rising edge at the LIN pin result in a remote wake-up request and the device switches to Fail-Safe mode. The INH pin is activated (switches to VS) and the internal termination resistor is switched on. The remote wake-up request is indicated by a low level at pin RXD and interrupts the microcontroller.

1.3.2 LOCAL WAKE UP THROUGH WKIN PIN

A falling edge at the WKin pin followed by a low level maintained for a certain period of time ($>t_{WKin}$) result in a local wake-up request and the device switches to Fail-Safe mode. The INH pin is activated (switches to VS) and the internal slave termination resistor is switched on. The local wake-up request is indicated by a low level at the TXD pin and a high level at the RXD pin, generating an interrupt for the microcontroller. Even when the WKin pin is low, it is possible to switch to Sleep mode via the EN pin. In this case, the wake-up signal has to be switched to high $>10 \mu$ s before the negative edge at WKin starts a new local wake-up request.

FIGURE 1-2: LIN WAKE-UP FROM SLEEP MODE

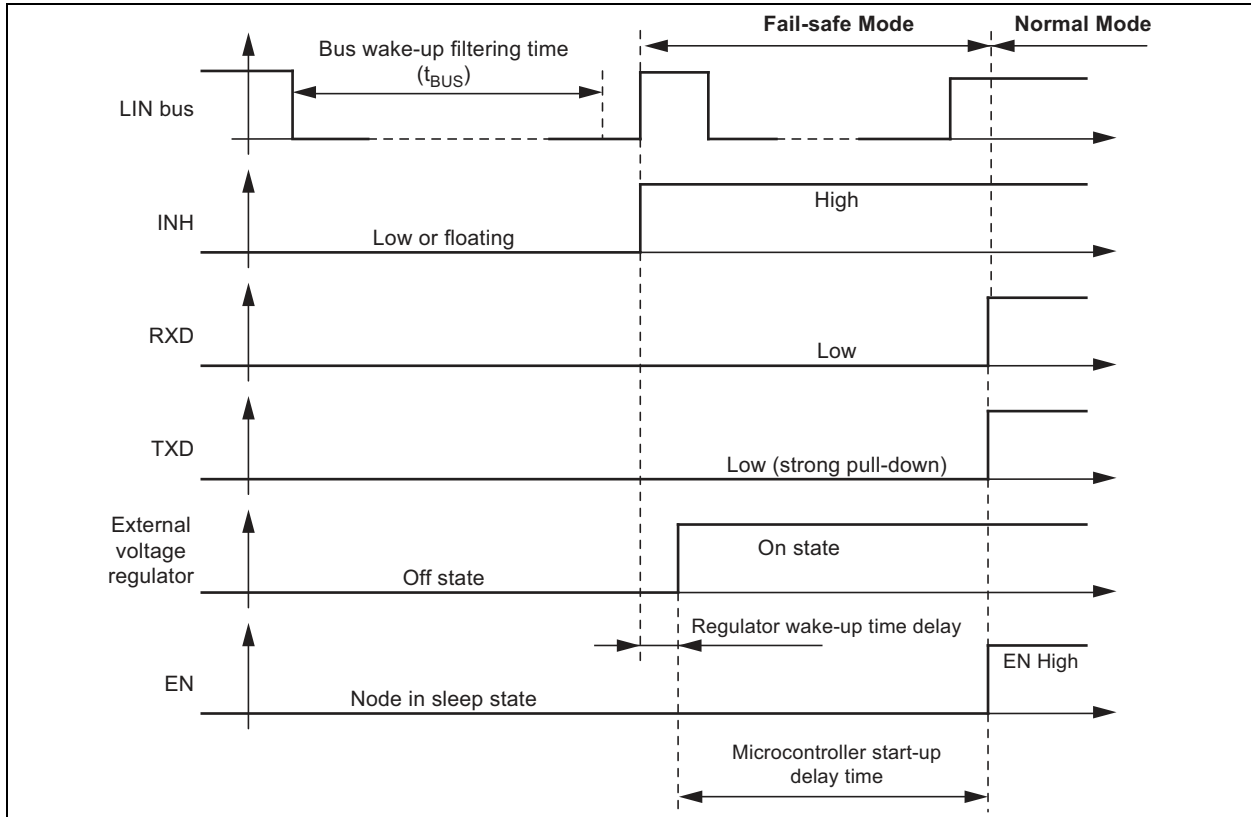
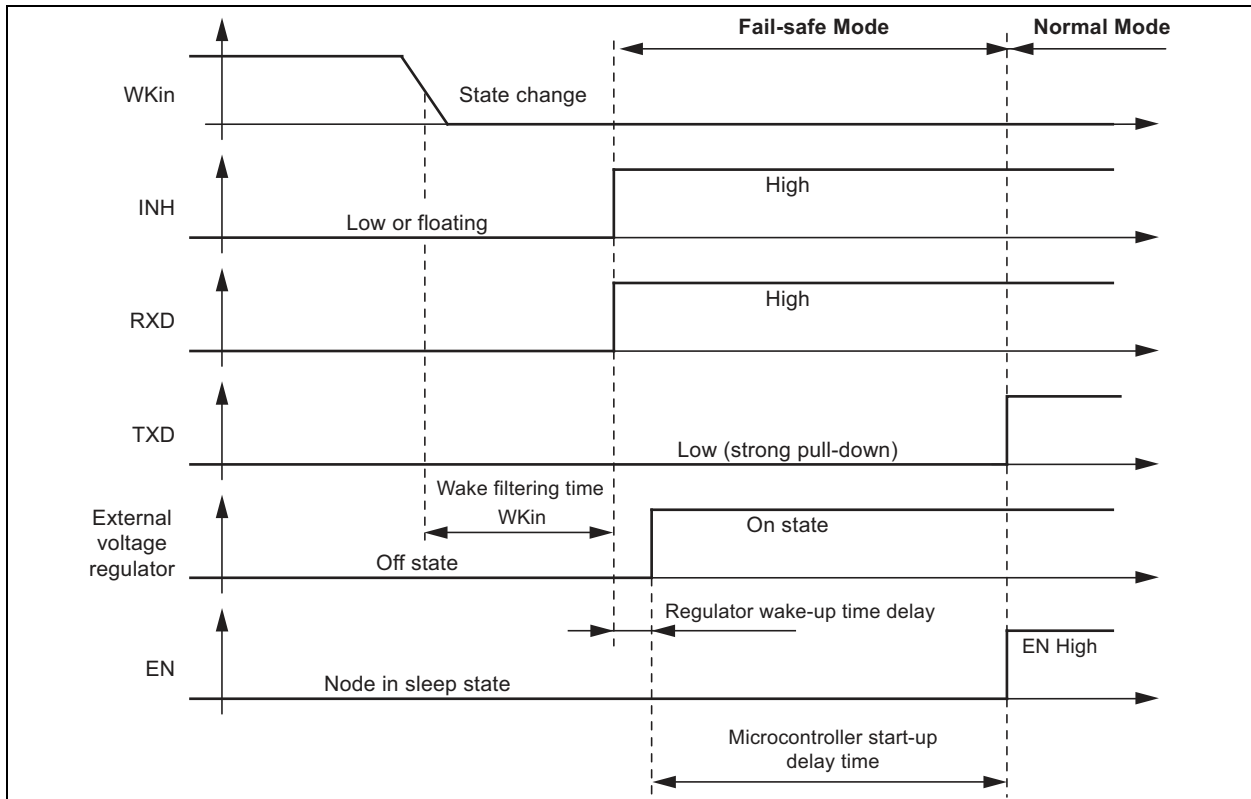

FIGURE 1-3: LOCAL WAKE-UP FROM WAKE-UP SWITCH



ATA663211

1.3.3 WAKE-UP SOURCE RECOGNITION

The device can distinguish between different wake-up sources. The wake-up source can be read on the TXD and RXD pin in Fail-Safe mode according to [Table 1-3](#), if an external pull-up resistor (typically 5 k Ω) has been

added on pin TXD to the power supply of the microcontroller. These flags are reset immediately if the microcontroller sets pin EN to high and the IC is in Normal mode.

TABLE 1-3: SIGNALING IN FAIL-SAFE MODE

Fail-Safe Sources	TXD	RXD
LIN wake up (LIN pin)	Low	Low
Local wake up (WKIn pin)	Low	High
$V_{S_{th}}$ (battery) undervoltage detection ($V_{VS} < 3.9V$)	High	Low

Note 1: Assuming an external pull-up resistor (typical 5 k Ω) has been added on pin TXD to the power supply of the microcontroller.

1.4 Behavior under Low Supply Voltage Condition

After the battery voltage has been connected to the application circuit, the voltage at the VS pin increases according to the block capacitor used in the application (see [Figure “ATA663211 Block Diagram”](#)). If V_{VS} is higher than the minimum VS operation threshold $V_{VS_{th_U_F_up}}$, the IC mode changes from Unpowered mode to Fail-Safe mode, the INH output is switched on and the LIN transceiver can be activated.

If, during Sleep mode, the voltage level of V_{VS} drops below the under-voltage detection threshold $V_{VS_{th_N_F_down}}$ (typically 4.3V), the operation mode is not changed and no wake up is possible. Only if the supply voltage on the VS pin drops below the VS operation threshold $V_{VS_{th_U_F_down}}$ (typically 2.05V), does the IC switch to Unpowered mode.

If, during Normal mode, the voltage level on the VS pin drops below the VS undervoltage detection threshold $V_{VS_{th_N_F_down}}$ (typically 4.3V), the IC switches to Fail-Safe mode. This means that the LIN transceiver is disabled in order to avoid malfunctions or false bus messages. If the supply voltage V_{VS} drops further below the VS operation threshold $V_{VS_{th_U_F_down}}$ (typically 2.05V), the IC switches to Unpowered mode and the INH output switches off.

1.5 Pin Descriptions

The descriptions of the pins are listed in [Table 1-4](#).

TABLE 1-4: PIN FUNCTIONING TABLE

Pin	Symbol	Function
1	RXD	Receive data output
2	EN	Enables Normal mode if the input is high
3	WKin	High-voltage input for local wake-up request. If not needed, connect directly to VS
4	TXD	Transmit data input
5	GND	Ground, heat slug
6	LIN	LIN bus line input/output
7	VS	Supply voltage
8	INH	Battery-related high-side switch output for controlling an external voltage regulator or to switch off the LIN master pull-up resistor; switched on after a wake-up request
Backside	EP	Heat slug, internally connected to the GND pin (only for the VDFN8 package)

1.5.1 OUTING PIN (RXD)

In Normal mode, this pin reports the state of the LIN bus to the microcontroller. LIN high (Recessive state) is indicated by a high level at RXD; LIN low (Dominant state) is indicated by a low level at RXD.

The output is an open drain; it is compatible with a 3.3V or 5V power supply. The AC characteristics are defined by an external pull-up resistor of 4.7 k Ω to 5V and a load capacitor of 20 pF.

In Unpowered mode, RXD is switched off.

1.5.2 ENABLE INPUT PIN (EN)

The enable input pin controls the operating mode of the device. If EN is high, the circuit is in Normal mode, with transmission paths from TXD to LIN and from LIN to RXD both active.

If EN is switched to low while TXD is still high, the device is forced to Sleep mode. This means that no data transmission is possible and current consumption is reduced to $I_{V_{Sleep}}$ typical 9 μ A.

The EN pin provides a pull-down resistor to force the transceiver into Recessive mode if EN is disconnected.

1.5.3 WKIN PIN

This pin is a high-voltage input used for waking up the device from Sleep mode. It is usually connected to an external switch in the application to generate a local wake up. A pull-up current source with typically 10 μ A is implemented. The voltage threshold for a wake-up signal is typically 2V below the V_{VS} voltage.

If a local wake up is not needed in the application, the WKin pin can be connected directly to the VS pin.

1.5.4 INPUT/OUTPUT (TXD)

In Normal mode, the TXD pin is the microcontroller interface for controlling the state of the LIN output. TXD must be pulled to ground in order to drive the LIN bus low. If TXD is high, the LIN output transistor is turned off and the bus is in the Recessive state. If the TXD pin stays at GND level while switching into Normal mode, it must be pulled to high level longer than 10 μ s before the LIN driver can be activated. This feature prevents the bus line from being accidentally driven to Dominant state after Normal mode has been activated (also in case of a short circuit at TXD to GND). During Fail-Safe mode, this pin is used as output and signals the fail-safe source.

The TXD pin provides a pull-down resistor in order to have a defined level if TXD is disconnected.

An internal timer prevents the bus line from being driven permanently in the Dominant state. If TXD is forced to low longer than $t_{dom} > 20$ ms, the LIN bus driver is switched to the Recessive state. Nevertheless, when switching to Sleep mode, the actual level at the TXD pin is relevant.

To reactivate the LIN bus driver, switch TXD to high (>10 μ s).

1.5.5 GROUND PIN (GND)

The IC does not affect the LIN bus in the event of GND disconnection. It is able to handle a ground shift of up to 11.5% of V_{VS} .

2.0 ELECTRICAL CHARACTERISTICS

Absolute Maximum Ratings †

Supply Voltage (V_{VS})	-0.3V to +40V
Logic Pins:	
Voltage Levels (RXD, TXD, EN, NRES) (V_{Logic})	-0.3V to +5.5V
Output DC currents (I_{Logic})	-5 mA to +5 mA

LIN

DC Voltage	-27V to +40V
Pulse time <500 ms	-27V to +43V

INH

DC Voltage	-0.3V to ($V_S + 0.3V$)
DC Voltage	-100 mA to +30 mA

WKin voltage levels

DC Voltage (V_{WKIN})	-0.3V to +40V
Transient voltage according to ISO7637 (coupling 1 nF, with 2.7K serial resistor)	-150V to +100V

ESD according to IBEE LIN EMC; test specification 1.0 following IEC 61000-4-2

Pin VS, LIN to GND, WKin (with external circuitry according to applications diagram)	±6 kV
--	-------

ESD HBM following STM5.1 with 1.5 k Ω /100 pF

Pin VS, LIN, INH to GND	±6 kV
Pin WKin to GND	±5 kV
HBM ESD ANSI/ESD-STM5.1 JESD22-A114 AEC-Q100 (002)	±3 kV
CDM ESD STM 5.3.1	±750V
Machine Model ESD AEC-Q100-RevF(003)	±200V
Virtual Junction Temperature (T_{VJ})	-40°C to +150°C
Storage Temperature (T_s)	-55°C to +150°C

† **Notice:** Stresses above those listed under “Maximum Ratings” may cause permanent damage to the device. This is a stress rating only and functional operation of the device at those or any other conditions above those indicated in the operational sections of this specification is not intended. Exposure to maximum rating conditions for extended periods may affect device reliability.

ATA663211

ELECTRICAL CHARACTERISTICS

Electrical Characteristics: Unless otherwise specified all values refer to GND pins, $5V < V_{VS} < 28V$, $-40^{\circ}C < T_{VJ} < 150^{\circ}C$.							
No.	Parameters	Symbol	Min.	Typ.	Max.	Unit	Conditions
1	VS Pin						
1.1	Nominal DC Voltage Range	V_{VS}	5	13.5	28	V	
1.3	Supply Current in Sleep mode	$I_{VSsleep}$	3	9	15	μA	Sleep mode $V_{LIN} > V_{VS} - 0.5V$ $V_{VS} < 14V$, $T = 27^{\circ}C$ (Note 1)
		$I_{VSsleep}$	3	11	18	μA	Sleep mode $V_{LIN} > V_{VS} - 0.5V$ $V_{VS} < 14V$
		$I_{VSsleep_short}$	20	50	100	μA	Sleep mode, $V_{LIN} = 0V$ bus shorted to GND $V_{VS} < 14V$
1.4	Supply Current in Normal Mode	I_{VSrec}	150	250	320	μA	Bus recessive $V_{VS} < 14V$
1.5	Supply Current in Normal Mode	I_{VSdom}	200	700	950	μA	Bus dominant (internal LIN pull-up resistor active) $V_{VS} < 14V$
1.6	Supply Current in Fail-Safe mode	I_{VSfail}	40	80	110	μA	Bus recessive $V_{VS} < 14V$
1.7	VS Undervoltage Threshold (switching from Normal to Fail-Safe mode)	$V_{VS_th_N_F_down}$	3.9	4.3	4.7	V	Decreasing supply voltage
		$V_{VS_th_F_N_up}$	4.1	4.6	4.9	V	Increasing supply voltage
1.8	VS Undervoltage Hysteresis	$V_{VS_hys_F_N}$	0.1	0.25	0.4	V	
1.9	VS Operation Threshold (switching to Unpowered mode)	$V_{VS_th_U_F_down}$	1.9	2.05	2.3	V	Switch to Unpowered mode
		$V_{VS_th_U_F_up}$	2.0	2.25	2.4	V	Switch from Unpowered to Fail-Safe mode
1.10	VS Undervoltage Hysteresis	$V_{VS_hys_U}$	0.1	0.2	0.3	V	
2	RXD Output Pin (Open Drain)						
2.1	Low-level Output Sink Capability	V_{RXDL}	—	0.2	0.4	V	Normal mode, $V_{LIN} = 0V$, $I_{RXD} = 2\text{ mA}$
2.3	High-level Leakage Current	I_{RXDH}	-3	—	+3	μA	Normal mode $V_{LIN} = V_{VS}$, $V_{RXD} = 5V$
3	TXD Input/Output Pin						
3.1	Low-level Voltage Input	V_{TXDL}	-0.3	—	+0.8	V	
3.2	High-level Voltage Input	V_{TXDH}	2	—	5.5	V	
3.5	Pull-down resistor	R_{TXD}	150	200	300	$k\Omega$	$V_{TXD} = 5V$
3.6	Low-level Leakage Current	I_{TXD}	-3	—	+3	μA	$V_{TXD} = 0V$

- Note 1:** 100% correlation tested.
Note 2: Characterized on samples.
Note 3: Design parameter.

ELECTRICAL CHARACTERISTICS (CONTINUED)

Electrical Characteristics: Unless otherwise specified all values refer to GND pins, $5V < V_{VS} < 28V$, $-40^{\circ}C < T_{VJ} < 150^{\circ}C$.							
No.	Parameters	Symbol	Min.	Typ.	Max.	Unit	Conditions
3.7	Low-level Output Sink Current at Wake-up Request	I_{TXD}	2	2.5	8	mA	Fail-Safe mode $V_{TXD} = 0.4V$
4	EN Input Pin						
4.1	Low-level Voltage Input	V_{ENL}	-0.3	—	+0.8	V	
4.2	High-level Voltage Input	V_{ENH}	2	—	5.5	V	
4.3	Pull-down Resistor	R_{EN}	50	125	200	k Ω	$V_{EN} = 5V$
4.4	Low-level Input Current	I_{EN}	-3	—	+3	μA	$V_{EN} = 0V$
6	WKin Input Pin						
6.1	High-level Input Voltage	V_{WKinH}	$V_{VS} - 1V$	—	$V_{VS} + 0.3V$	V	
6.2	Low-level Input Voltage	V_{WKinL}	-1	—	$V_{VS} - 3.3V$	V	Initializes a wake-up signal
6.3	WKin Pull-up Current	I_{WKIN}	-30	-10		μA	$V_{VS} < 28V$, $V_{WKin} = 0V$
6.4	High-level Leakage Current	I_{WKINL}	-5	—	+5	μA	$V_{VS} = 28V$, $V_{WKin} = 28V$
6.5	Debounce Time of Low Pulse for Wake up via WKin	t_{Wkin}	50	100	150	μs	$V_{WKin} = 0V$
7	INH Output Pin						
7.1	Switch on Resistance Between VS and INH	$R_{DSON,INH}$	—	12	25	Ω	Normal or Fail-Safe mode $I_{INH} = -15\text{ mA}$
7.2	Leakage Current	$I_{LEAK,INH}$	-3	—	+3	μA	Transceiver in Sleep mode, $V_{INH} = 0V/28V$, $V_{VS} = 28V$
7.3	High-level Voltage	V_{INH}	$V_{VS} - 0.375$	—	V_{VS}	V	Normal or Fail-Safe mode $I_{INH} = -15\text{ mA}$
10	LIN Bus Driver: Bus Load Conditions: Load 1 (small): 1 nF, 1 k Ω ; Load 2 (large): 10 nF, 500 Ω ; External Pull-up $R_{RXD} = 4.7\text{ k}\Omega$; $C_{RXD} = 20\text{ pF}$, Load 3 (medium): 6.8 nF, 660 Ω characterized on samples, 12.7 and 12.8 specifies the timing parameters for proper operation at 20 kb/s and 12.9 and 12.10 at 10.4 kb/s						
10.1	Driver Recessive Output Voltage	V_{BUSrec}	$0.9 * V_{VS}$	—	V_{VS}	V	Load1/Load2
10.2	Driver Dominant Voltage	V_{LoSUP}	—	—	1.2	V	$V_{VS} = 7V$ $R_{load} = 500\Omega$
10.3	Driver Dominant Voltage	V_{HiSUP}	—	—	2	V	$V_{VS} = 18V$ $R_{load} = 500\Omega$
10.4	Driver Dominant Voltage	V_{LoSUP_1k}	0.6	—	—	V	$V_{VS} = 7V$ $R_{load} = 1000\Omega$
10.5	Driver Dominant Voltage	V_{HiSUP_1k}	0.8	—	—	V	$V_{VS} = 18V$ $R_{load} = 1000\Omega$
10.6	Pull-up Resistor to VS	R_{LIN}	20	30	47	k Ω	The serial diode is mandatory

Note 1: 100% correlation tested.
 2: Characterized on samples.
 3: Design parameter.

ATA663211

ELECTRICAL CHARACTERISTICS (CONTINUED)

Electrical Characteristics: Unless otherwise specified all values refer to GND pins, $5V < V_{VS} < 28V$, $-40^{\circ}C < T_{VJ} < 150^{\circ}C$.							
No.	Parameters	Symbol	Min.	Typ.	Max.	Unit	Conditions
10.7	Voltage Drop at the Serial Diodes	$V_{SerDiode}$	0.4	—	1.0	V	In pull-up path with R_{slave} $I_{SerDiode} = 10 \text{ mA}$ (Note 3)
10.8	LIN Current Limitation $V_{BUS} = V_{BAT_MAX}$	I_{BUS_LIM}	40	120	200	mA	
10.9	Input leakage current at the receiver including pull-up resistor as specified	$I_{BUS_PAS_dom}$	-1	-0.35	—	mA	Input leakage current driver off $V_{BUS} = 0V$ $V_{BAT} = 12V$
10.10	Leakage Current LIN Recessive	$I_{BUS_PAS_rec}$	—	10	20	μA	Driver off $8V < V_{BAT} < 18V$ $8V < V_{BUS} < 18V$ $V_{BUS} \geq V_{BAT}$
10.11	Leakage current when control unit is disconnected from ground. Loss of local ground must not affect communication in the residual network	$I_{BUS_NO_gnd}$	-10	+0.5	+10	μA	$GND_{Device} = V_{VS}$ $V_{BAT} = 12V$ $0V < V_{BUS} < 18V$
10.12	Leakage current at disconnected battery. Node has to sustain the current that can flow under this condition. Bus must remain operational under this condition.	$I_{BUS_NO_bat}$	—	0.1	2	μA	V_{BAT} disconnected $V_{SUP_device} = GND$ $0V < V_{BUS} < 18V$
10.13	Capacitance on LIN pin to GND	C_{LIN}	—	—	20	pF	(Note 3)
11	LIN Bus Receiver						
11.1	Center of Receiver Threshold	V_{BUS_CNT}	$0.475 * V_{VS}$	$0.5 * VS$	$0.525 * V_{VS}$	V	$V_{BUS_CNT} = (V_{th_dom} + V_{th_rec})/2$
11.2	Receiver Dominant State	V_{BUSdom}	-27	—	$0.4 * VS$	V	$V_{EN} = 5V$
11.3	Receiver Recessive State	V_{BUSrec}	$0.6 * V_{VS}$	—	40	V	$V_{EN} = 5V$
11.4	Receiver Input Hysteresis	V_{BUShys}	$0.028 * V_{VS}$	$0.1 * VS$	$0.175 * V_{VS}$	V	$V_{hys} = V_{th_rec} - V_{th_dom}$
11.5	Pre-wake Detection LIN High-level Input Voltage	V_{LINH}	$V_{VS} - 2V$	—	$V_{VS} + 0.3V$	V	
11.6	Pre-wake Detection LIN Low-level Input Voltage	V_{LINL}	-27	—	$V_{VS} - 3.3V$	V	Activates the LIN receiver

- Note** 1: 100% correlation tested.
 2: Characterized on samples.
 3: Design parameter.

ELECTRICAL CHARACTERISTICS (CONTINUED)

Electrical Characteristics: Unless otherwise specified all values refer to GND pins, $5V < V_{VS} < 28V$, $-40^{\circ}C < T_{VJ} < 150^{\circ}C$.							
No.	Parameters	Symbol	Min.	Typ.	Max.	Unit	Conditions
12	Internal timers						
12.1	Dominant time for wake up via LIN bus	t_{bus}	50	100	150	μs	$V_{LIN} = 0V$
12.2	Time delay for mode change from Fail-Safe into Normal mode via EN pin	t_{norm}	5	15	20	μs	$V_{EN} = 5V$
12.3	Time delay for mode change from Normal mode to Sleep mode via EN pin	t_{sleep}	5	15	20	μs	$V_{EN} = 0V$
12.4	Time delay for mode change from Sleep mode to Normal mode via EN pin	t_{s_n}	—	150	300	μs	$V_{EN} = 5V$
12.5	TXD dominant time-out time	t_{dom}	20	40	60	ms	$V_{TXD} = 0V$
12.7	Duty Cycle 1	D1	0.396	—	—	—	$TH_{Rec(max)} = 0.744 \times V_{VS}$ $TH_{Dom(max)} = 0.581 \times V_{VS}$ $V_{VS} = 7.0V$ to $18V$ $t_{Bit} = 50 \mu s$ $D1 = t_{bus_rec(min)}/(2 \times t_{Bit})$
12.8	Duty Cycle 2	D2	—	—	0.581	—	$TH_{Rec(min)} = 0.422 \times V_{VS}$ $TH_{Dom(min)} = 0.284 \times V_{VS}$ $V_{VS} = 7.6V$ to $18V$ $t_{Bit} = 50 \mu s$ $D2 = t_{bus_rec(max)}/(2 \times t_{Bit})$
12.9	Duty Cycle 3	D3	0.417	—	—	—	$TH_{Rec(max)} = 0.778 \times V_{VS}$ $TH_{Dom(max)} = 0.616 \times V_{VS}$ $V_{VS} = 7.0V$ to $18V$ $t_{Bit} = 96 \mu s$ $D3 = t_{bus_rec(min)}/(2 \times t_{Bit})$
12.10	Duty Cycle 4	D4	—	—	0.590	—	$TH_{Rec(min)} = 0.389 \times V_{VS}$ $TH_{Dom(min)} = 0.251 \times V_{VS}$ $V_{VS} = 7.6V$ to $18V$ $t_{Bit} = 96 \mu s$ $D4 = t_{bus_rec(max)}/(2 \times t_{Bit})$
12.11	Slope time falling and rising edge at LIN	t_{SLOPE_fall} t_{SLOPE_rise}	3.5	—	22.5	μs	$V_{VS} = 7.0V$ to $18V$
13	Receiver electrical AC parameters of the LIN physical layer LIN receiver, RXD load conditions: $C_{RXD} = 20 pF$, $R_{RXD} = 4.7 k\Omega$						
13.1	Propagation delay of receiver	t_{rx_pd}	—	—	6	μs	$V_{VS} = 7.0V$ to $18V$ $t_{rx_pd} = \max(t_{rx_pdr}, t_{rx_pdf})$
13.2	Symmetry of receiver propagation delay rising edge minus falling edge	t_{rx_sym}	-2	—	+2	μs	$V_{VS} = 7.0V$ to $18V$ $t_{rx_sym} = t_{rx_pdr} - t_{rx_pdf}$

- Note** 1: 100% correlation tested.
 2: Characterized on samples.
 3: Design parameter.

ATA663211

FIGURE 2-1: DEFINITION OF BUS TIMING CHARACTERISTICS

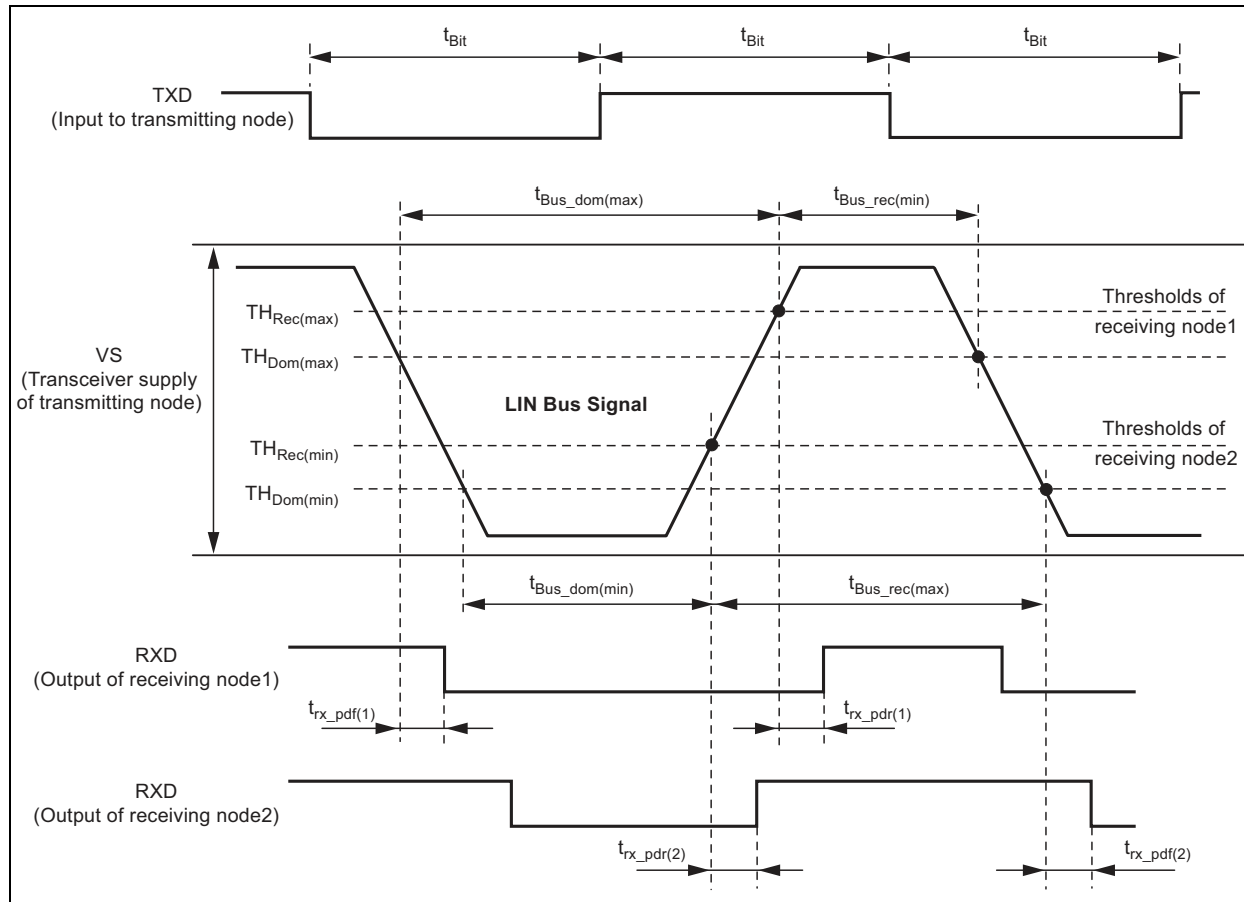

TEMPERATURE SPECIFICATIONS 8-LEAD VDFN

Parameters	Sym.	Min.	Typ.	Max.	Unit
Thermal resistance virtual junction to exposed thermal pad	R_{thvJC}	—	10	—	K/W
Thermal resistance virtual junction to ambient, where exposed thermal pad is soldered to the PCB, according to JEDEC	R_{thvJA}	—	50	—	K/W
Thermal shutdown	T_{off}	150	165	180	°C
Thermal shutdown hysteresis	T_{hys}	—	10	—	°C

TEMPERATURE SPECIFICATIONS 8-LEAD SOIC

Parameters	Sym.	Min.	Typ.	Max.	Unit
Thermal resistance virtual junction to ambient, with a heat sink at GND (pin 5) on PCB (fused lead frame to pin 5)	R_{thvJA}	—	80	—	K/W
Thermal shutdown	T_{off}	150	165	180	°C
Thermal shutdown hysteresis	T_{hys}	5	10	20	°C

3.0 PACKAGING INFORMATION

3.1 Package marking Information

8-Lead VDFN (3 x 3 mm)

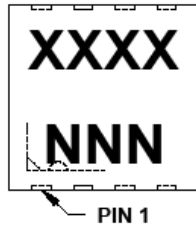

Example ATA663211

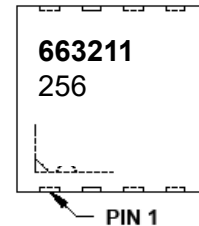

8-Lead SOIC (3.90 mm)

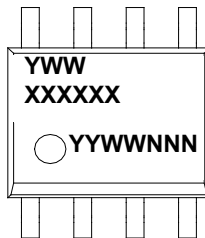

Example ATA663211

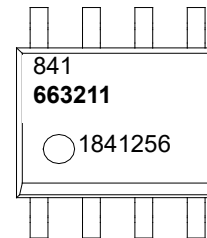

Legend:	XX...X	Customer-specific information
	WW	Week code (week of January 1 is week '01')
	NNN	Alphanumeric traceability code
	(e3)	Pb-free JEDEC designator for Matte Tin (Sn)
	*	This package is Pb-free. The Pb-free JEDEC designator (e3) can be found on the outer packaging for this package.
	•, ▲, ▼	Pin one index is identified by a dot, delta up, or delta down (triangle mark).

Note: In the event the full Microchip part number cannot be marked on one line, it will be carried over to the next line, thus limiting the number of available characters for customer-specific information. Package may or may not include the corporate logo.

Underbar (_) symbol may not be to scale.

ATA663211

8-Lead Very Thin Plastic Dual Flat, No Lead Package (Q8B) - 3x3 mm Body [VDFN] With 2.40x1.60 mm Exposed Pad and Stepped Wettable Flanks

Note: For the most current package drawings, please see the Microchip Packaging Specification located at <http://www.microchip.com/packaging>

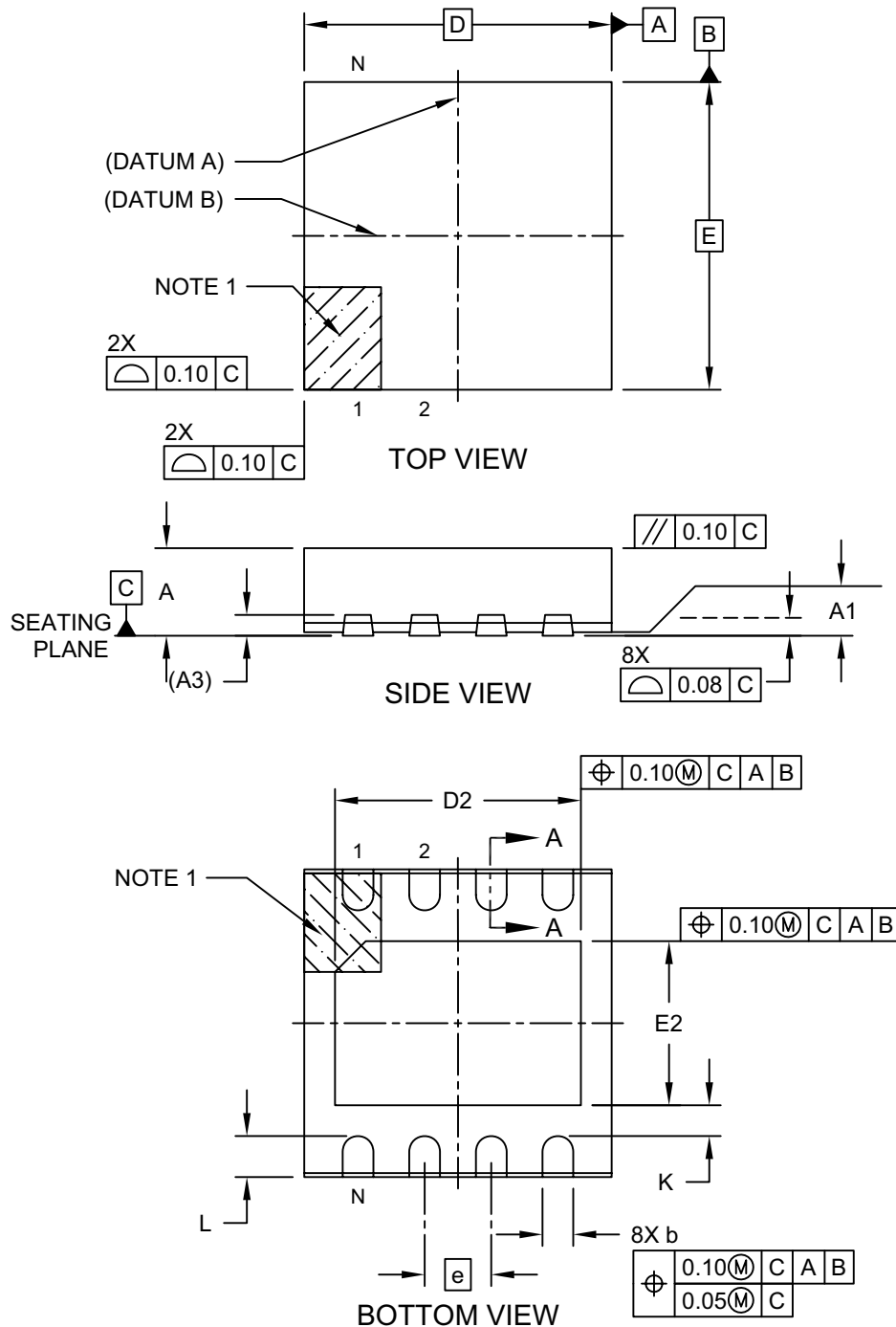

Microchip Technology Drawing C04-21358 Rev B Sheet 1 of 2

8-Lead Very Thin Plastic Dual Flat, No Lead Package (Q8B) - 3x3 mm Body [VDFN] With 2.40x1.60 mm Exposed Pad and Stepped Wettable Flanks

Note: For the most current package drawings, please see the Microchip Packaging Specification located at <http://www.microchip.com/packaging>

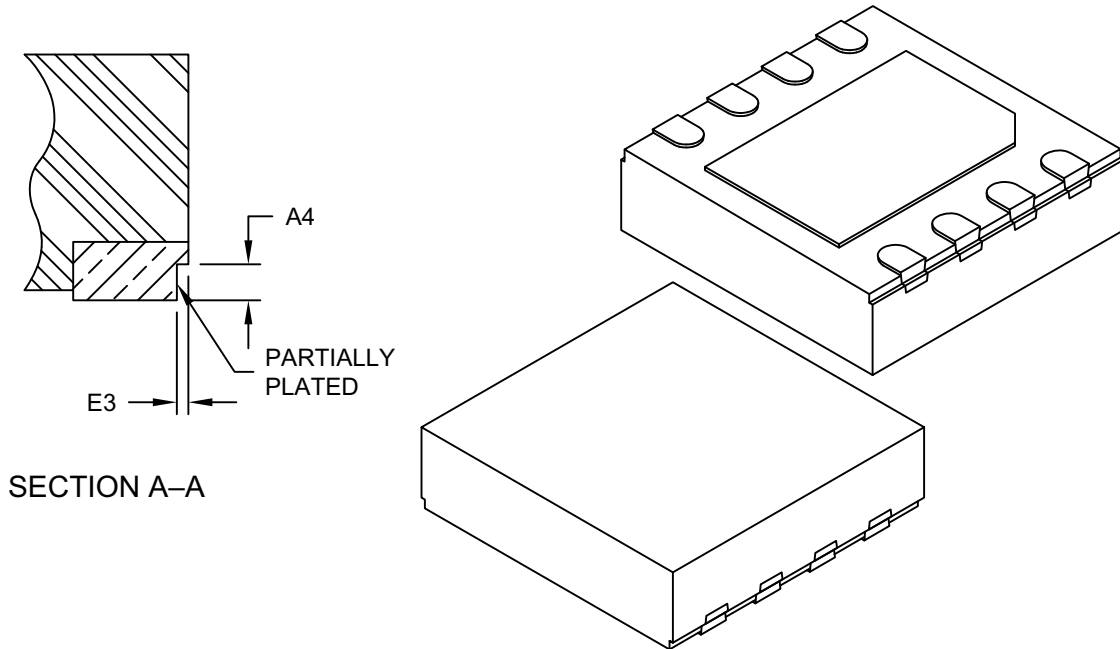

Dimension Limits	Units	MILLIMETERS		
		MIN	NOM	MAX
Number of Terminals	N	8		
Pitch	e	0.65 BSC		
Overall Height	A	0.80	0.85	0.90
Standoff	A1	0.00	0.03	0.05
Terminal Thickness	A3	0.203 REF		
Overall Length	D	3.00 BSC		
Exposed Pad Length	D2	2.30	2.40	2.50
Overall Width	E	3.00 BSC		
Exposed Pad Width	E2	1.50	1.60	1.70
Terminal Width	b	0.25	0.30	0.35
Terminal Length	L	0.35	0.40	0.45
Terminal-to-Exposed-Pad	K	0.20	-	-
Wettable Flank Step Cut Depth	A4	0.10	0.13	0.15
Wettable Flank Step Cut Width	E3	-	-	0.04

Notes:

- Pin 1 visual index feature may vary, but must be located within the hatched area.
- Package is saw singulated
- Dimensioning and tolerancing per ASME Y14.5M
 BSC: Basic Dimension. Theoretically exact value shown without tolerances.
 REF: Reference Dimension, usually without tolerance, for information purposes only.

Microchip Technology Drawing C04-21358 Rev B Sheet 2 of 2

ATA663211

8-Lead Very Thin Plastic Dual Flat, No Lead Package (Q8B) - 3x3 mm Body [VDFN] With 2.40x1.60 mm Exposed Pad and Stepped Wettable Flanks

Note: For the most current package drawings, please see the Microchip Packaging Specification located at <http://www.microchip.com/packaging>

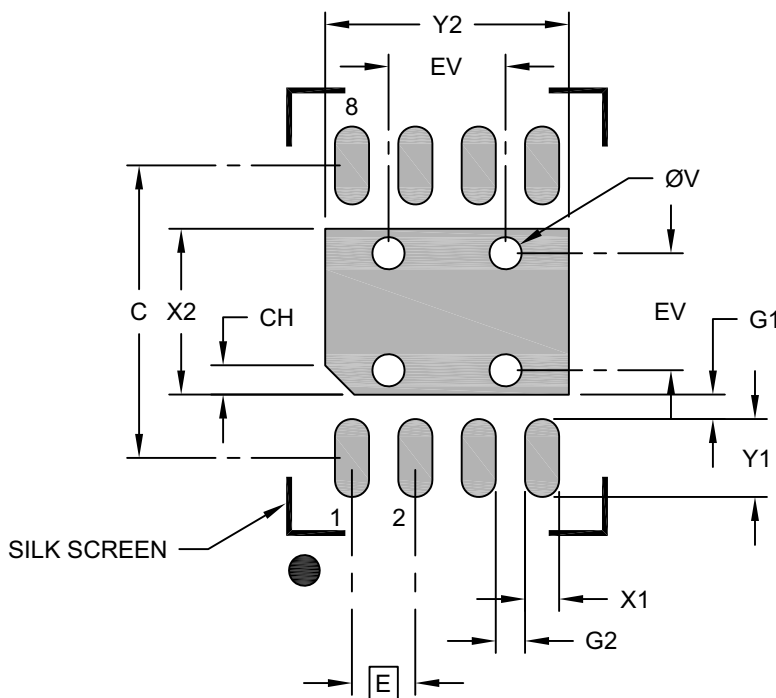

RECOMMENDED LAND PATTERN

Dimension Limits	Units	MILLIMETERS		
		MIN	NOM	MAX
Contact Pitch	E	0.65 BSC		
Optional Center Pad Width	X2			1.70
Optional Center Pad Length	Y2			2.50
Contact Pad Spacing	C		3.00	
Contact Pad Width (X8)	X1			0.35
Contact Pad Length (X8)	Y1			0.80
Contact Pad to Center Pad (X8)	G1	0.20		
Contact Pad to Contact Pad (X6)	G2	0.20		
Pin 1 Index Chamfer	CH	0.20		
Thermal Via Diameter	V		0.33	
Thermal Via Pitch	EV		1.20	

Notes:

- Dimensioning and tolerancing per ASME Y14.5M
BSC: Basic Dimension. Theoretically exact value shown without tolerances.
- For best soldering results, thermal vias, if used, should be filled or tented to avoid solder loss during reflow process

Microchip Technology Drawing C04-23358 Rev B

8-Lead Plastic Small Outline (OA) - Narrow, 3.90 mm (.150 In.) Body [SOIC]

Note: For the most current package drawings, please see the Microchip Packaging Specification located at <http://www.microchip.com/packaging>

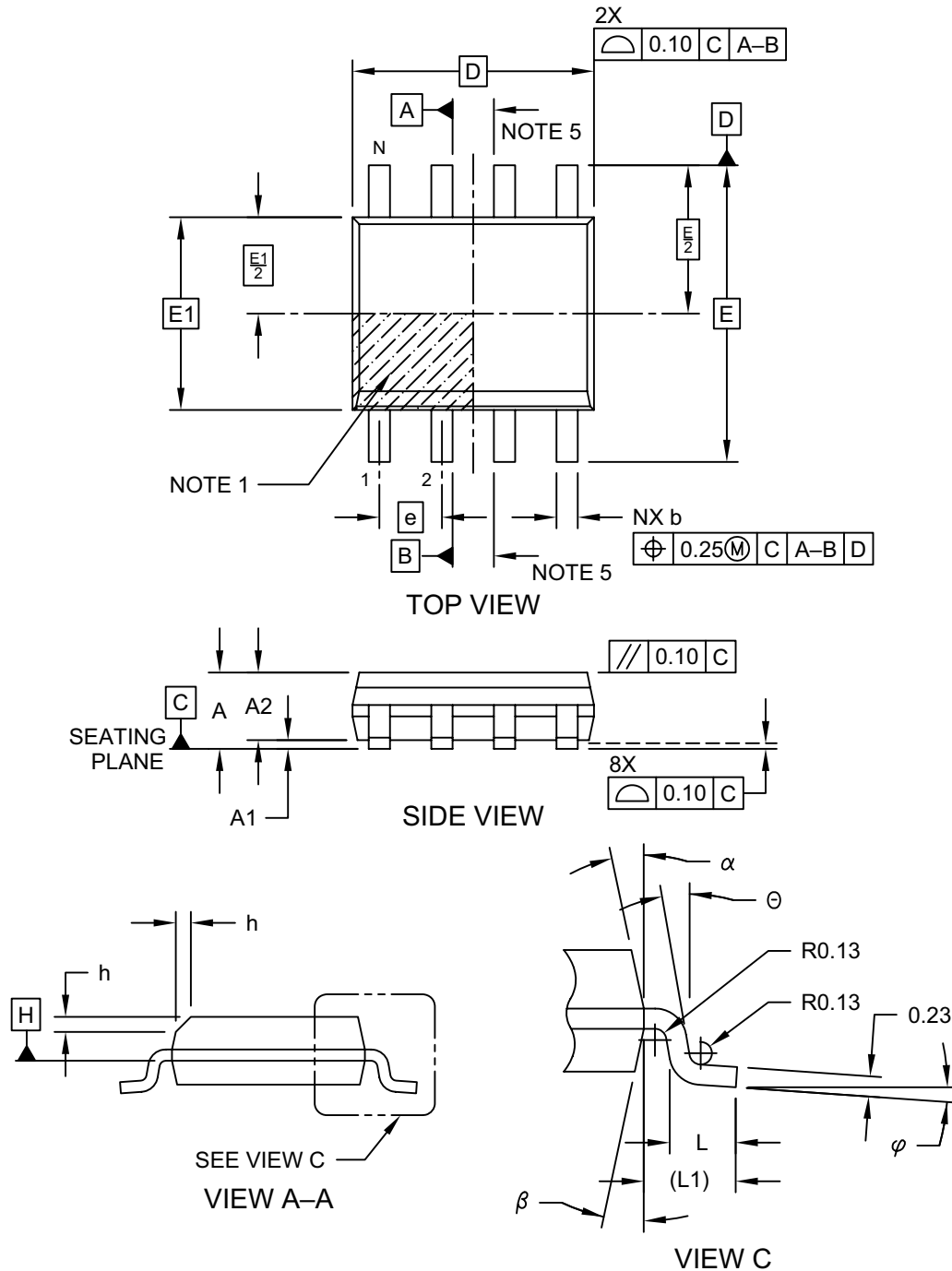

Microchip Technology Drawing No. C04-057-OA Rev D Sheet 1 of 2

ATA663211

8-Lead Plastic Small Outline (OA) - Narrow, 3.90 mm (.150 In.) Body [SOIC]

Note: For the most current package drawings, please see the Microchip Packaging Specification located at <http://www.microchip.com/packaging>

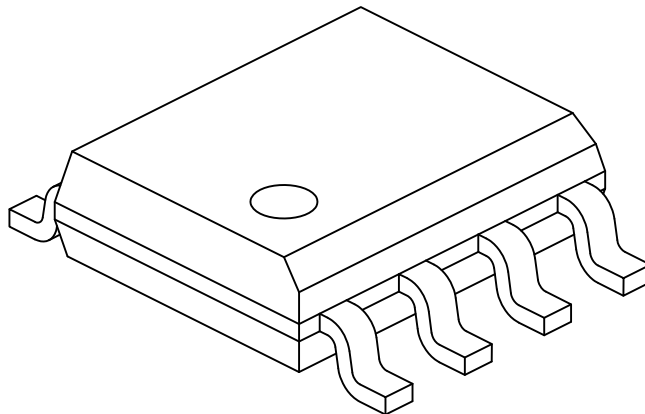

Dimension Limits	Units	MILLIMETERS		
		MIN	NOM	MAX
Number of Pins	N	8		
Pitch	e	1.27 BSC		
Overall Height	A	-	-	1.75
Molded Package Thickness	A2	1.25	-	-
Standoff §	A1	0.10	-	0.25
Overall Width	E	6.00 BSC		
Molded Package Width	E1	3.90 BSC		
Overall Length	D	4.90 BSC		
Chamfer (Optional)	h	0.25	-	0.50
Foot Length	L	0.40	-	1.27
Footprint	L1	1.04 REF		
Foot Angle	φ	0°	-	8°
Lead Thickness	c	0.17	-	0.25
Lead Width	b	0.31	-	0.51
Mold Draft Angle Top	α	5°	-	15°
Mold Draft Angle Bottom	β	5°	-	15°

Notes:

- Pin 1 visual index feature may vary, but must be located within the hatched area.
- § Significant Characteristic
- Dimensions D and E1 do not include mold flash or protrusions. Mold flash or protrusions shall not exceed 0.15mm per side.
- Dimensioning and tolerancing per ASME Y14.5M
BSC: Basic Dimension. Theoretically exact value shown without tolerances.
REF: Reference Dimension, usually without tolerance, for information purposes only.
- Datums A & B to be determined at Datum H.

Microchip Technology Drawing No. C04-057-OA Rev D Sheet 2 of 2

8-Lead Plastic Small Outline (OA) - Narrow, 3.90 mm Body [SOIC]

Note: For the most current package drawings, please see the Microchip Packaging Specification located at <http://www.microchip.com/packaging>

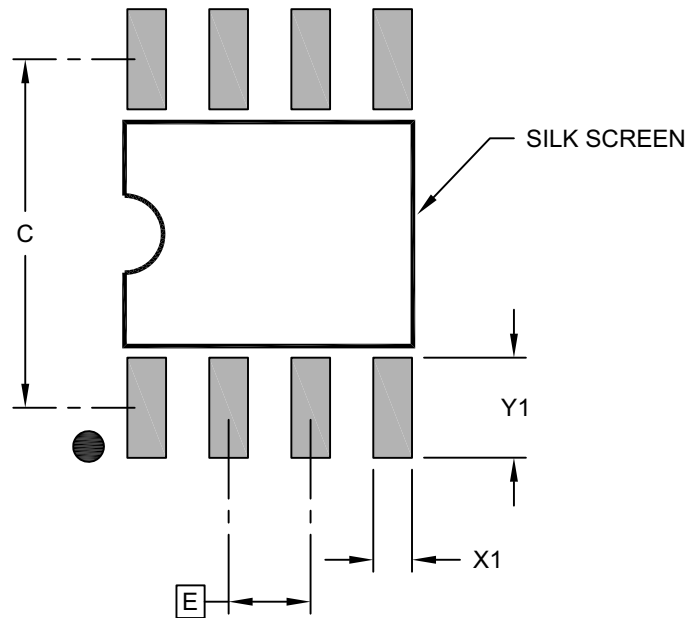

RECOMMENDED LAND PATTERN

Dimension Limits	Units	MILLIMETERS		
		MIN	NOM	MAX
Contact Pitch	E	1.27 BSC		
Contact Pad Spacing	C		5.40	
Contact Pad Width (X8)	X1			0.60
Contact Pad Length (X8)	Y1			1.55

Notes:

1. Dimensioning and tolerancing per ASME Y14.5M
BSC: Basic Dimension. Theoretically exact value shown without tolerances.

Microchip Technology Drawing C04-2057-OA Rev B

ATA663211

NOTES:

APPENDIX A: REVISION HISTORY

Revision B (April 2020)

- [3.1 “Package marking Information”](#) updated
- Minor editorial changes

Revision A (April 2019)

- Original release of this document
- Minor text updates
- This document replaces
Atmel – 9359D-AUTO-10/16

ATA663211

NOTES:

PRODUCT IDENTIFICATION SYSTEM

To order or obtain information, e.g., on pricing or delivery, refer to the factory or the listed sales office.

PART NO.	—	XX	[X] ⁽¹⁾	[X]	—	[X]
Device	Package	Tape and Reel Option	Package Directives Classification	Device Variant		
<p>Device: ATA663211</p> <p>Package: GA = 8-Lead SOIC GB = 8-Lead VDFN</p> <p>Tape and Reel Option: Q = 3 mm diameter Tape and Reel⁽¹⁾</p> <p>Package Directives Classification: W = Package according to RoHS⁽¹⁾</p>						
<p>Examples:</p> <p>a) ATA663211-GAQW 8-Lead SOIC, Tape and Reel, Package according to RoHS</p> <p>b) ATA663211-GBQW 8-Lead VDFN, Tape and Reel, Package according to RoHS</p> <p>Note 1: Tape and Reel identifier only appears in the catalog part number description. This identifier is used for ordering purposes and is not printed on the device package. Check with your Microchip Sales Office for package availability with the Tape and Reel option.</p> <p>2: RoHS compliant; maximum concentration value of 0.09% (900 ppm) for Bromine (Br) and Chlorine (Cl) and less than 0.15% (1500 ppm) total Bromine (Br) and Chlorine (Cl) in any homogeneous material. Maximum concentration value of 0.09% (900 ppm) for Antimony (Sb) in any homogeneous material</p>						

ATA663211

NOTES:

Note the following details of the code protection feature on Microchip devices:

- Microchip products meet the specification contained in their particular Microchip Data Sheet.
- Microchip believes that its family of products is one of the most secure families of its kind on the market today, when used in the intended manner and under normal conditions.
- There are dishonest and possibly illegal methods used to breach the code protection feature. All of these methods, to our knowledge, require using the Microchip products in a manner outside the operating specifications contained in Microchip's Data Sheets. Most likely, the person doing so is engaged in theft of intellectual property.
- Microchip is willing to work with the customer who is concerned about the integrity of their code.
- Neither Microchip nor any other semiconductor manufacturer can guarantee the security of their code. Code protection does not mean that we are guaranteeing the product as “unbreakable.”

Code protection is constantly evolving. We at Microchip are committed to continuously improving the code protection features of our products. Attempts to break Microchip's code protection feature may be a violation of the Digital Millennium Copyright Act. If such acts allow unauthorized access to your software or other copyrighted work, you may have a right to sue for relief under that Act.

Information contained in this publication regarding device applications and the like is provided only for your convenience and may be superseded by updates. It is your responsibility to ensure that your application meets with your specifications. MICROCHIP MAKES NO REPRESENTATIONS OR WARRANTIES OF ANY KIND WHETHER EXPRESS OR IMPLIED, WRITTEN OR ORAL, STATUTORY OR OTHERWISE, RELATED TO THE INFORMATION, INCLUDING BUT NOT LIMITED TO ITS CONDITION, QUALITY, PERFORMANCE, MERCHANTABILITY OR FITNESS FOR PURPOSE. Microchip disclaims all liability arising from this information and its use. Use of Microchip devices in life support and/or safety applications is entirely at the buyer's risk, and the buyer agrees to defend, indemnify and hold harmless Microchip from any and all damages, claims, suits, or expenses resulting from such use. No licenses are conveyed, implicitly or otherwise, under any Microchip intellectual property rights unless otherwise stated.

Microchip received ISO/TS-16949:2009 certification for its worldwide headquarters, design and wafer fabrication facilities in Chandler and Tempe, Arizona; Gresham, Oregon and design centers in California and India. The Company's quality system processes and procedures are for its PIC® MCUs and dsPIC® DSCs, KEELOQ® code hopping devices, Serial EEPROMs, microperipherals, nonvolatile memory and analog products. In addition, Microchip's quality system for the design and manufacture of development systems is ISO 9001:2000 certified.

**QUALITY MANAGEMENT SYSTEM
CERTIFIED BY DNV
= ISO/TS 16949 =**

Trademarks

The Microchip name and logo, the Microchip logo, AnyRate, AVR, AVR logo, AVR Freaks, BitCloud, chipKIT, chipKIT logo, CryptoMemory, CryptoRF, dsPIC, FlashFlex, flexPWR, Helder, JukeBlox, KeeLoq, Klear, LANCheck, LINK MD, maXStylus, maXTouch, MediaLB, megaAVR, MOST, MOST logo, MPLAB, OptoLyzer, PIC, picoPower, PICSTART, PIC32 logo, Prochip Designer, QTouch, SAM-BA, SpyNIC, SST, SST Logo, SuperFlash, tinyAVR, UNI/O, and XMEGA are registered trademarks of Microchip Technology Incorporated in the U.S.A. and other countries.

ClockWorks, The Embedded Control Solutions Company, EtherSynch, Hyper Speed Control, HyperLight Load, IntellIMOS, mTouch, Precision Edge, and Quiet-Wire are registered trademarks of Microchip Technology Incorporated in the U.S.A.

Adjacent Key Suppression, AKS, Analog-for-the-Digital Age, Any Capacitor, AnyIn, AnyOut, BodyCom, CodeGuard, CryptoAuthentication, CryptoAutomotive, CryptoCompanion, CryptoController, dsPICDEM, dsPICDEM.net, Dynamic Average Matching, DAM, ECAN, EtherGREEN, In-Circuit Serial Programming, ICSP, INICnet, Inter-Chip Connectivity, JitterBlocker, KlearNet, KlearNet logo, memBrain, Mindi, MiWi, motorBench, MPASM, MPF, MPLAB Certified logo, MPLIB, MPLINK, MultiTRAK, NetDetach, Omniscient Code Generation, PICDEM, PICDEM.net, PICKit, PICtail, PowerSmart, PureSilicon, QMatrix, REAL ICE, Ripple Blocker, SAM-ICE, Serial Quad I/O, SMART-I.S., SQI, SuperSwitcher, SuperSwitcher II, Total Endurance, TSHARC, USBCheck, VariSense, ViewSpan, WiperLock, Wireless DNA, and ZENA are trademarks of Microchip Technology Incorporated in the U.S.A. and other countries.

SQTP is a service mark of Microchip Technology Incorporated in the U.S.A.

Silicon Storage Technology is a registered trademark of Microchip Technology Inc. in other countries.

GestIC is a registered trademark of Microchip Technology Germany II GmbH & Co. KG, a subsidiary of Microchip Technology Inc., in other countries.

All other trademarks mentioned herein are property of their respective companies.

© 2020, Microchip Technology Incorporated, All Rights Reserved.
ISBN: 978-1-5224-5902-6



MICROCHIP

Worldwide Sales and Service

AMERICAS

Corporate Office
2355 West Chandler Blvd.
Chandler, AZ 85224-6199
Tel: 480-792-7200
Fax: 480-792-7277
Technical Support:
<http://www.microchip.com/support>
Web Address:
www.microchip.com

Atlanta

Duluth, GA
Tel: 678-957-9614
Fax: 678-957-1455

Austin, TX

Tel: 512-257-3370

Boston

Westborough, MA
Tel: 774-760-0087
Fax: 774-760-0088

Chicago

Itasca, IL
Tel: 630-285-0071
Fax: 630-285-0075

Dallas

Addison, TX
Tel: 972-818-7423
Fax: 972-818-2924

Detroit

Novi, MI
Tel: 248-848-4000

Houston, TX

Tel: 281-894-5983

Indianapolis

Noblesville, IN
Tel: 317-773-8323
Fax: 317-773-5453
Tel: 317-536-2380

Los Angeles

Mission Viejo, CA
Tel: 949-462-9523
Fax: 949-462-9608
Tel: 951-273-7800

Raleigh, NC

Tel: 919-844-7510

New York, NY

Tel: 631-435-6000

San Jose, CA

Tel: 408-735-9110
Tel: 408-436-4270

Canada - Toronto

Tel: 905-695-1980
Fax: 905-695-2078

ASIA/PACIFIC

Australia - Sydney
Tel: 61-2-9868-6733

China - Beijing
Tel: 86-10-8569-7000

China - Chengdu
Tel: 86-28-8665-5511

China - Chongqing
Tel: 86-23-8980-9588

China - Dongguan
Tel: 86-769-8702-9880

China - Guangzhou
Tel: 86-20-8755-8029

China - Hangzhou
Tel: 86-571-8792-8115

China - Hong Kong SAR
Tel: 852-2943-5100

China - Nanjing
Tel: 86-25-8473-2460

China - Qingdao
Tel: 86-532-8502-7355

China - Shanghai
Tel: 86-21-3326-8000

China - Shenyang
Tel: 86-24-2334-2829

China - Shenzhen
Tel: 86-755-8864-2200

China - Suzhou
Tel: 86-186-6233-1526

China - Wuhan
Tel: 86-27-5980-5300

China - Xian
Tel: 86-29-8833-7252

China - Xiamen
Tel: 86-592-2388138

China - Zhuhai
Tel: 86-756-3210040

ASIA/PACIFIC

India - Bangalore
Tel: 91-80-3090-4444

India - New Delhi
Tel: 91-11-4160-8631

India - Pune
Tel: 91-20-4121-0141

Japan - Osaka
Tel: 81-6-6152-7160

Japan - Tokyo
Tel: 81-3-6880-3770

Korea - Daegu
Tel: 82-53-744-4301

Korea - Seoul
Tel: 82-2-554-7200

Malaysia - Kuala Lumpur
Tel: 60-3-7651-7906

Malaysia - Penang
Tel: 60-4-227-8870

Philippines - Manila
Tel: 63-2-634-9065

Singapore
Tel: 65-6334-8870

Taiwan - Hsin Chu
Tel: 886-3-577-8366

Taiwan - Kaohsiung
Tel: 886-7-213-7830

Taiwan - Taipei
Tel: 886-2-2508-8600

Thailand - Bangkok
Tel: 66-2-694-1351

Vietnam - Ho Chi Minh
Tel: 84-28-5448-2100

EUROPE

Austria - Wels
Tel: 43-7242-2244-39
Fax: 43-7242-2244-393

Denmark - Copenhagen
Tel: 45-4485-5910
Fax: 45-4485-2829

Finland - Espoo
Tel: 358-9-4520-820

France - Paris
Tel: 33-1-69-53-63-20
Fax: 33-1-69-30-90-79

Germany - Garching
Tel: 49-8931-9700

Germany - Haan
Tel: 49-2129-3766400

Germany - Heilbronn
Tel: 49-7131-72400

Germany - Karlsruhe
Tel: 49-721-625370

Germany - Munich
Tel: 49-89-627-144-0
Fax: 49-89-627-144-44

Germany - Rosenheim
Tel: 49-8031-354-560

Israel - Ra'anana
Tel: 972-9-744-7705

Italy - Milan
Tel: 39-0331-742611
Fax: 39-0331-466781

Italy - Padova
Tel: 39-049-7625286

Netherlands - Drunen
Tel: 31-416-690399
Fax: 31-416-690340

Norway - Trondheim
Tel: 47-7288-4388

Poland - Warsaw
Tel: 48-22-3325737

Romania - Bucharest
Tel: 40-21-407-87-50

Spain - Madrid
Tel: 34-91-708-08-90
Fax: 34-91-708-08-91

Sweden - Gothenberg
Tel: 46-31-704-60-40

Sweden - Stockholm
Tel: 46-8-5090-4654

UK - Wokingham
Tel: 44-118-921-5800
Fax: 44-118-921-5820