

OMRON

Smart Sensor

ZG2 Series 2D Measurement Sensor

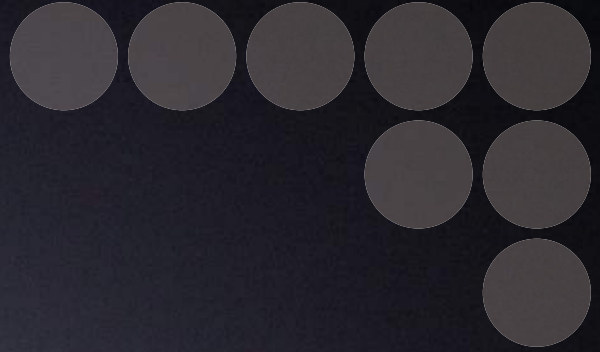

2D Laser Profile Measurement System

ZG2 debut! Achieving stable measurement
through innovative technology



realizing



Easier and much more accurate for profile measurement

Stable measurement regardless of color, material, and shape complexity

< Simple configuration >

Plug & play! Just connecting Sensor head and Controller.

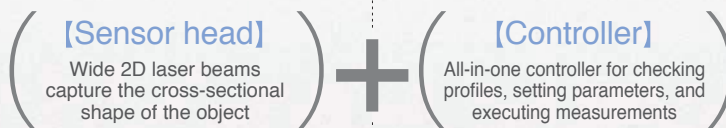

Setup Support Software Smart Monitor ZG2

The ZG2 Smart Monitor software allows easy data logging, trend monitoring and full parameter configuration.

*Equipped with sensor controller ZG2-WDC_1A as standard.

<Enhanced Performance> **Evolution**

Through innovative technology the ZG2 offers superior performance to conventional 2D sensors.

Industry's best

12x the conventional sensitivity

Measurement can be performed at a stable level in a large amount of ambient light, even on objects that do not reflect light so much such as black ones.

Luster side of painted object and black rubber
CASE-001

Industry's best

2.5x the conventional inclination tolerance

Measurement performance margin for transparent objects and glossy object has been significantly improved. Measurement is performed at a stable level even when an object is inclined or shaking slightly.

Inclined transparent object and glossy object
CASE-002

10x the conventional speed

The speed of the multi-sensitivity function, effective for measuring multi-material objects or complex shapes, has been increased. Measurement can be performed at a stable level even in high-speed takt-time lines.

High-speed takt-time line
CASE-003

A wide variety of measurement items

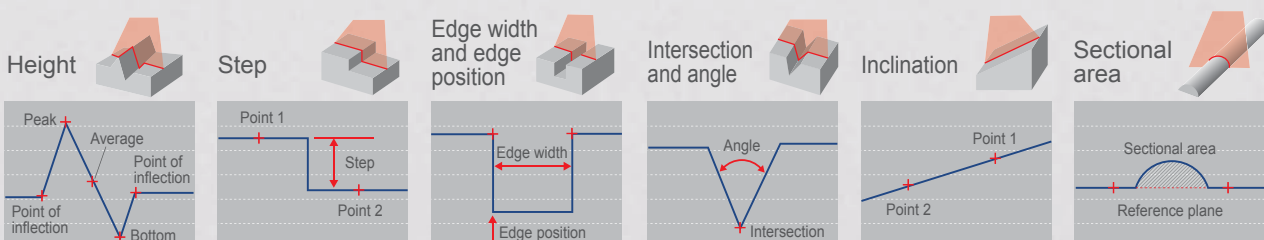

CASE-001 Evolution

Industry's best

12x the conventional sensitivity

7x the conventional ambient illumination

Painted object and black rubber

Dark colored materials or materials with a matt finish, like black rubber often do not reflect sufficient light to maintain a stable measurement. They are also susceptible to the influences of ambient light so are difficult to measure using conventional laser measurement sensors. The ZG2 solves these problems because it is supersensitive and significantly reduces ambient noise. It also has an APS function to automatically tune parameters such as a receiver's sensitivity and background suppression level at optimal levels according to the ambient light conditions. Shape profiles can also be easily reproduced at optimal conditions to achieve high precision measurement. Measurement of moving objects is possible because measurement can be performed within a short exposure time.

※ For details, see descriptions of the APS function (page 9) and new optical system ONPS (page 8).

Flush and Gap on car doors

Gaps on car doors can be measured at a stable level without being influenced by the color.



Overlap or damage when manufacturing tires

The ZG2 can check for overlap or damage of black rubber.



Inclined transparent object or glossy object

On an object with strong regular reflection components such as luster sides and transparent objects, the amount of light reflection significantly reduces when the object is slightly inclined, lowering measurement stability. The sensor head ZG2-WDS3VT with a high-performance gauss lens is the solution for the problem. Its inclination acceptance range has been increased to 2.5 times as compared to conventional models so transparent objects can be measured up to a $\pm 5^\circ$ inclination at a stable level. Because the ZG2 has this function, it is useful for assembly inspections for lenses and glass plates.

※ For details, see descriptions of the high-performance gauss lens (page 8).

Assembly inspection of electronic parts

The ZG2 can measure parts with glass or a glossy object such as CCDs, CMOSs, and crystal splinters of quartz resonators at a stable level. It can be used for assembly inspections of parts because it can measure steps on a substrate or package side.

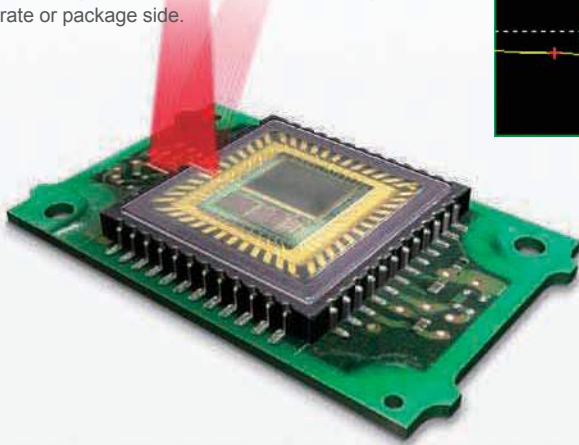

Assembly inspection of lenses

The ZG2 can measure the step between the peak of a lens and lens holder to check if they are assembled properly.

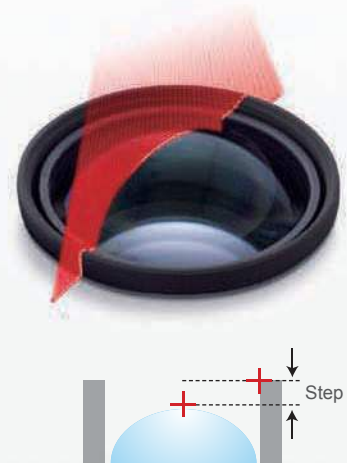

High-speed takt-time line

Reproducing a clear, stable profile is difficult for objects with both black and metal sides, cylindrical objects, and complex-shaped objects because the amount of laser reflection and reflection angle differ according to the positions of different materials on such objects. To solve the problem, Omron's unique "multi-sensitivity function" has been improved. The measurement speed for the function has been increased so that the function can be used in high-speed takt-time lines.

※ For details, see descriptions of high-speed multi sensitivity (page 9).

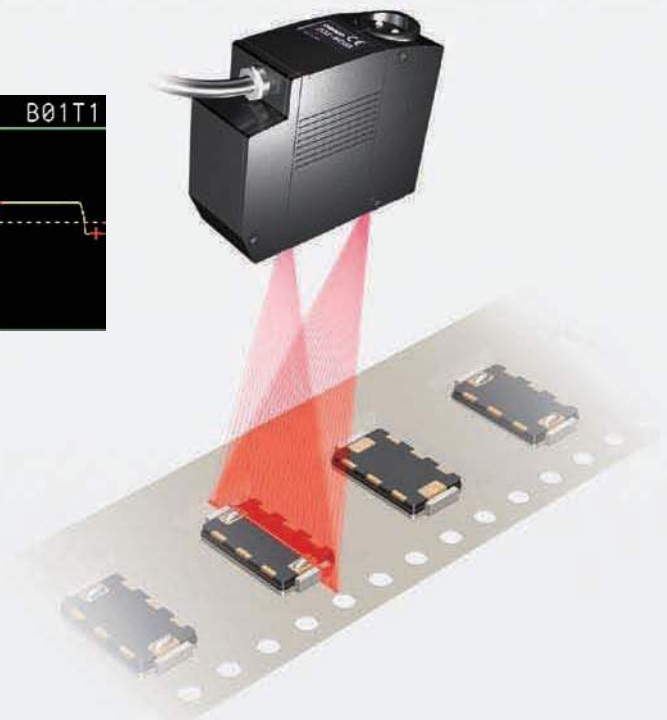

CASE-004 Evolution

Measurement of wide target

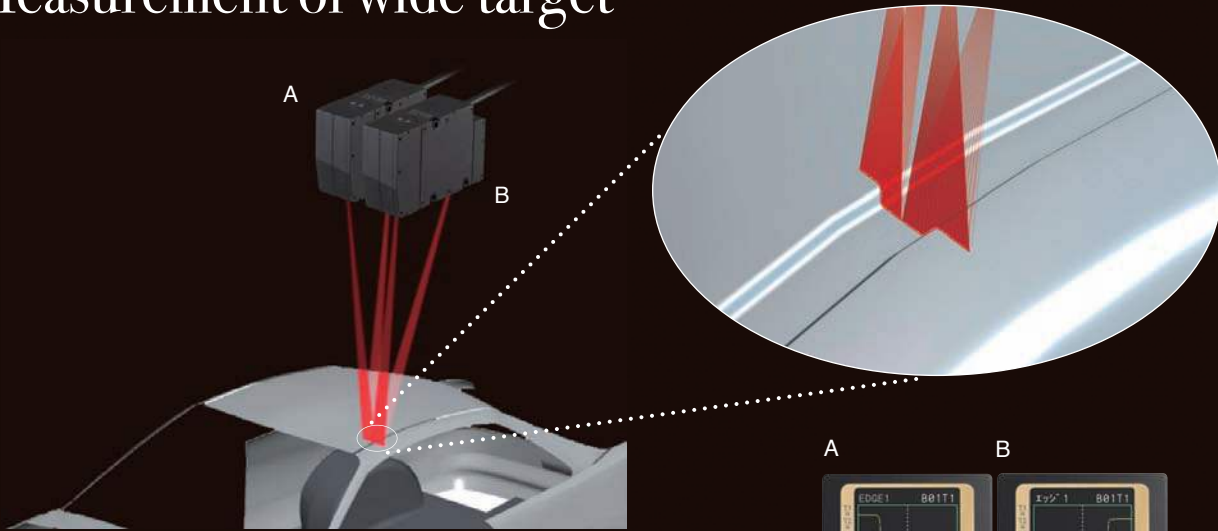

Two sensor controllers are linked and two sensor heads perform synchronous measurement to increase the measurement range to 140 mm. With the link method, the ZG2 Series provides the optimum solution for any intended purpose.

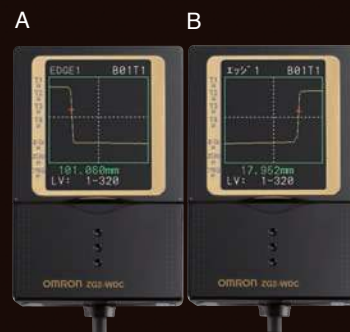

CASE-007

Simplified Sensor Head Adjustment

The "installation correction function" automatically makes adjustments to parallelly align the sensor head with the target. The function eliminates the gap between the reference plane and sensor head inclination caused during setup and in turn significantly reduces the time spent for adjustment during the setup of the sensor head.

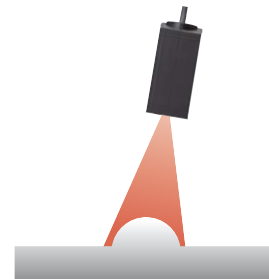

* When inclination is great, a measurement error may occur. Check the measurement accuracy in actual measurement conditions prior to use.

CASE-009

Simultaneous measurement of two or more points

Measurements can be performed for up to eight measurement points selected from a profile simultaneously so different types of inspections can be carried out at the same time when necessary. Measurement items can be selected from among 20 items including edge width, height, inclination, step, and sectional area according to the intended purpose.

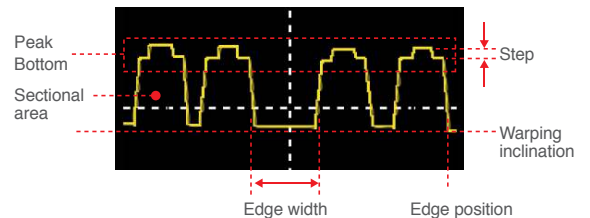

CASE-011 Evolution

Data Storage and Trend Analysis

A data storage unit is now available for storing measurement values and profile data. Data can be loaded on a PC from a memory card or via serial communication and can be used to manage manufacturing history, monitor tendency, or analyze defects.



* For logging capacity, see System Configuration (page 10).

CASE-005 Evolution

Measurement by finding the inflection point of the object

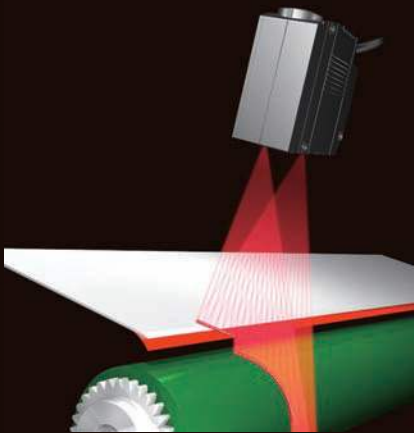

The sensor has a measurement function to capture points where an angle varies on a target as an "inflection point." This function enables the measurement of a step or edge width of a feature point of a target.

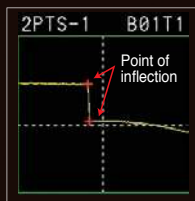

CASE-006 Evolution

Measurement of position and angle of intersection

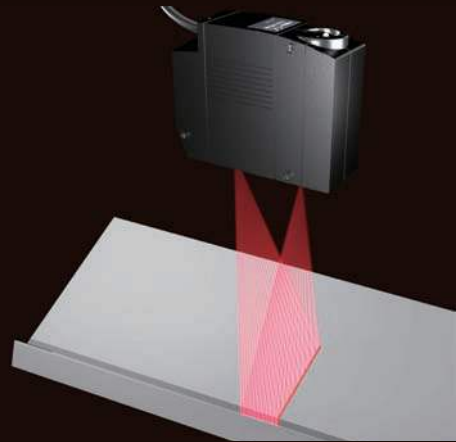

The sensor has a function to measure the "intersection coordinates" and "intersection angle" on two linear lines on a target. An example of a useful application of this function is tracer control for a welding torch for targets to be welded.

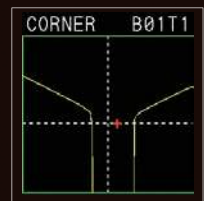

CASE-008

Intuitive setting

Basic setting requires only three steps. Omron's unique interface maximizes the sensing performance with extremely simple operation.

1st STEP	2nd STEP	3rd STEP
<p>Display a profile.</p> <p>A profile is displayed as soon as the power is turned ON.* Adjust the Sensor Head position while viewing the profile on the screen.</p> <p>* In the FUN mode</p>	<p>Select a measurement item.</p> <p>Select the icon for the item to be measured, such as height, step, or sectional area.</p>	<p>Specify the measurement range.</p> <p>Simply enclose the range to be measured with the box on the profile. The ZG2 automatically optimizes the sensing conditions.</p>

* Screen images are simulated.

CASE-0010

Active Position Compensation Control

The position and inclination are automatically corrected even for targets for which positioning is difficult. This helps to perform stable in-line measurement.

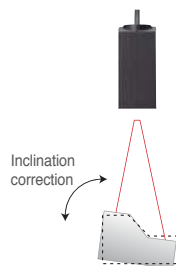

Example) 2-point step measurement



When a target is inclined, step measurement result is greater than the actual value.

Measurement can be performed accurately utilizing the "inclination correction function."

CASE-012 Evolution

Large Programme Capacity

Measurement conditions for up to 16 items (16 banks) can be registered in the sensor controller unit. Banks can be easily switched by inputting a signal, inputting a command, or operating a key. When the data storage unit is used, up to 4,096 banks can be registered for quick response to flexible production lines.

Measurement conditions for up to **4,096** items can be stored in the data storage unit.



Measurement conditions for up to **16** items can be stored in the sensor controller.

Sensor Head

2 Dimensional Measurement

A light-cutting method is used. The widely-spread laser beam is projected on the measurement object to measure its cross-sectional shape.

Measurement principle

A band-like laser beam is projected on the measurement object, and the reflection from the object is received by the CCD. A shape profile of the measurement object is formed based on the principle of triangular distance measurement. Since 2D data of the X and Z axes are measured simultaneously, there is no need to move either the sensor or measurement object.

[Three CCD modes]

Since three CCD modes are available; high-speed mode, standard mode, and high-precision mode, the ZG2 can be used for processes that require high speed or inspections that require higher precision. The measurement center distance remains fixed even when the mode is changed so the sensor head position does not need to be adjusted.

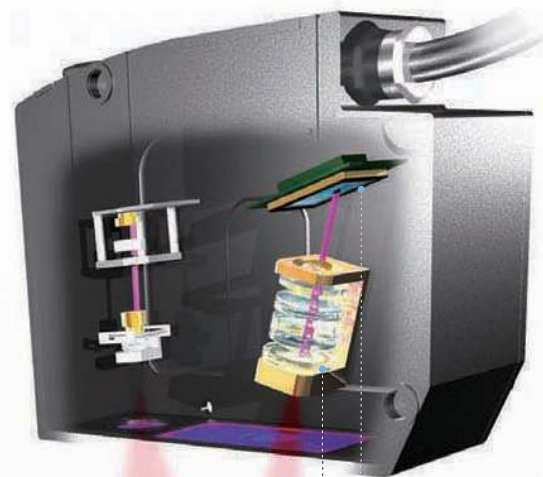

Evolution Suitable for transparent and mirror surface objects

High-performance gauss lens 「TAGG」

Patent pending Mounted on the ZG2-WDS3VT

The new gauss lens was born out of Omron's passion for sensing technology. In the lens, a coupling lens structure including an aspherical lens is used, which allows for clear, bright images with low aberration, even though it is a wide-angle lens. Previous lens designs could not receive sufficient light reflection when objects were inclined. Using the new TAGG lens design, light reflection can be received at angles up to $\pm 5^\circ$. The lens shows excellent performance for stable measurement of mirror and gloss surfaces with large amounts of regular reflection components and also transparent objects such as glass.

[TAGG]: Transparency And Gloss surface detector by Gauss composition

Evolution Resists the effects of ambient light

New optical system ONPS Patent pending

Utilizing its unique optical filter technology, Omron has developed a new optical system where ambient light components are effectively removed so that only necessary reflection components from the object can be received. A control system is also used in which the laser exposure period and the CCD receiving period are synchronized. The combined effect of these has achieved ambient illumination resistance of 7,000 lx, seven times higher than conventional models. Measurement can be performed at a stable level without being influenced by fluorescent light or other surrounding conditions.

[ONPS]: Optical Noise Protection System

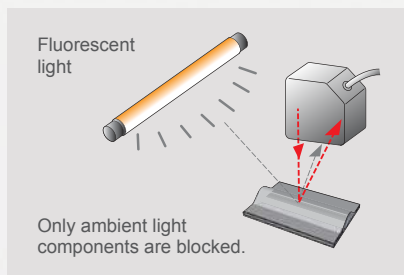

Sensor Controller

Powerful functionality in a compact design

The business card sized ZG2 controller incorporates a built in LCD monitor for profile visualization. The LCD display also gives access to the ZG2's intuitive and simple to use setup screens.

The controller also includes a USB and RS-232 interface for easy connectivity.

Operation interface

Measurement conditions are indicated by easy-to-understand icons.

Select an icon directly with a function key.



Input/output interface

Equipped with USB and RS-232C port as standard.

The real-time parallel output unit for extending a parallel port is available (optional).



Full-scale photograph

Evolution

Stable measurement regardless of material and color

APS function Patent pending

A feature of 2D measurement sensors is projecting a wide beam onto an object to be measured in order to simultaneously check dimensions such as the width and gap. However, since light reflects differently according to the material, color, and shape of an object's surface, experience and skill are required to obtain the most adequate profile which is a prerequisite of high-precision measurement. As a result, measurement sometimes takes a long time. The ZG2 has an "APS function" developed by combining a variety of techniques for obtaining profiles. An optimal profile with no lost part can be obtained with the simple push of a button, even from black objects, and also in conditions with ambient light where adjustment was difficult using conventional sensors. Optimal tuning is simple and easy so startup work time can be significantly reduced.



Optimal tuning for the measurement object with the simple push of a button



Lost part on a profile due to insufficient amount of light received

[APS]: Auto Profile Search

Evolution

Stable measurement for complex shapes

High-speed multi sensitivity Patent No. 3575693

Omron's unique "multi-sensitivity function" is used to measure complex shapes by varying the intensity of the laser light over different areas of reflectivity across the object. The function has been further improved in the ZG2 Series. The optimal profile is formed according to the reflection of the object approximately two to ten times faster than in former models. The ZG2 can now perform measurements on higher-speed takt-time lines.

[Example]

A workpiece with a mountain-shaped reference plane. Reflectivity varies from part to part.

Light reflected from these parts do not directly enter the CCD.

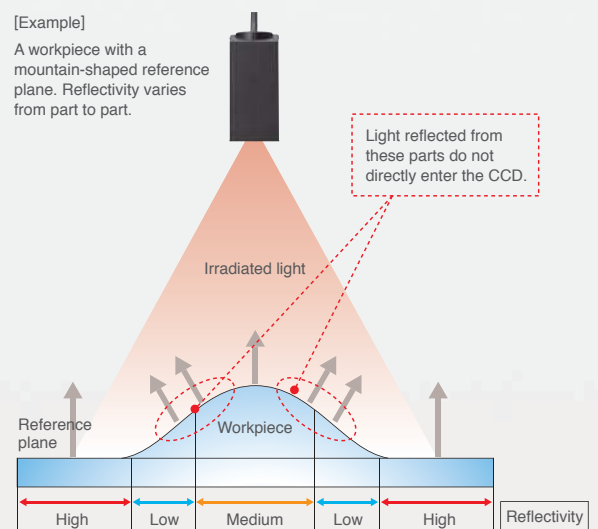

Principle

While switching sensitivity levels for workpieces of which reflectivity varies from part to part, the sensor inputs multiple images and combines parts taken at the optimal sensitivity into a single image. This produces an image of the entire workpiece.

Effect

Image obtained from ordinary processing

Image obtained using the multi-sensitivity function



System Configuration

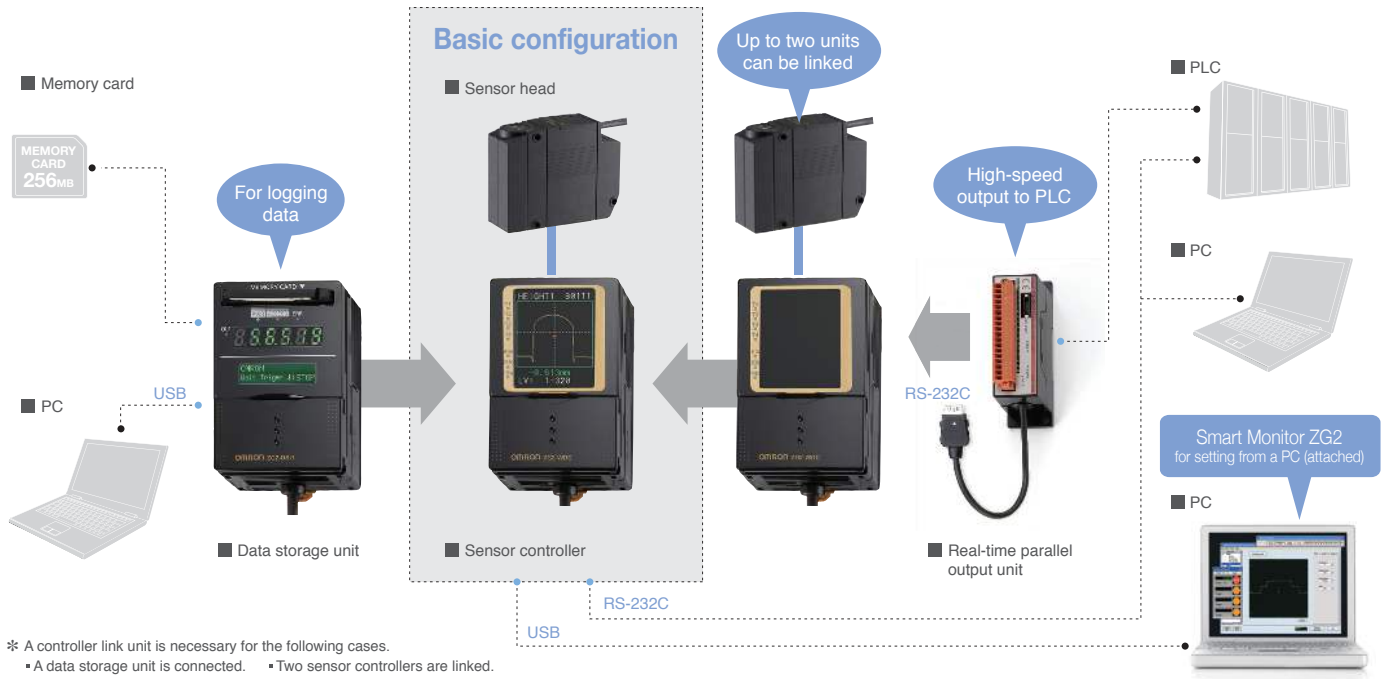

Evolution 27 m max. Sensor Head Extension Cables

Highly-flexible extension cables of four different lengths are available. The distance between the sensor head and sensor controller can be extended up to 27 m without delaying image input periods.

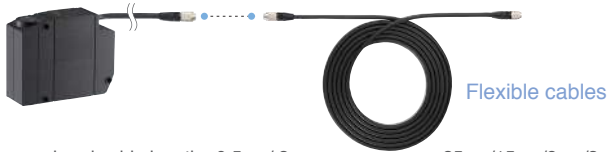

Evolution Multi function unit Data Storage Unit ZG2-DSU

[Collect measurement values]

Up to 65,000 values can be stored in the memory of the main unit. Up to 7,150,000 values (65,000 values x 110 files) can be saved in a memory card (256 MB).

[Save profile data]

Up to 5,120 object profiles can be saved. Up to 35,328 profiles (256 profiles x 138 files) can be saved in a memory card (256 MB). Saved data can be used for analyzing defects.

[Readiness for high-mix production]

Up to 4,096 banks of data for stage replacement can be saved for quick response for high-mix production lines.

* Saving capacity differs according to set conditions. See the Ratings and Specifications table.

Setting, Analysis, and Data Storage via PC Setup Support Software Smart Monitor ZG2

Using the software equipped with the sensor controller ZG2-WDC_1A, sensing conditions can be easily specified using a PC. Intricate profiles, which cannot be sufficiently checked on the Controller's LCD monitor, can be enlarged for thorough checking on a PC screen.

[Measurement value logging]

Measurement value logging results are displayed in a time series. They are useful for trend management.

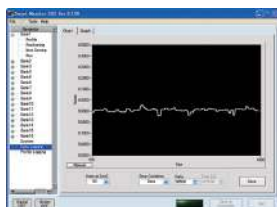

[Profile logging] Evolution

In addition to measurement values, profile data logging is now enabled.

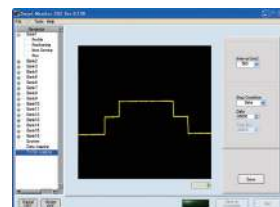

[Setup support]

Helps to check intricate profiles that cannot be sufficiently checked on the controller's LCD monitor and provides easy-to-view setting lists for easy setting.

Profiles are displayed on a large screen. They can be enlarged by the [Zoom] button.

Connect the PC where Smart Monitor ZG2 is used and the sensor controller by the USB cable attached to the sensor controller (ZG2-WDC_1A) together with Smart Monitor ZG2. For System Requirements, refer to page 13.

Order Information

Sensor Heads

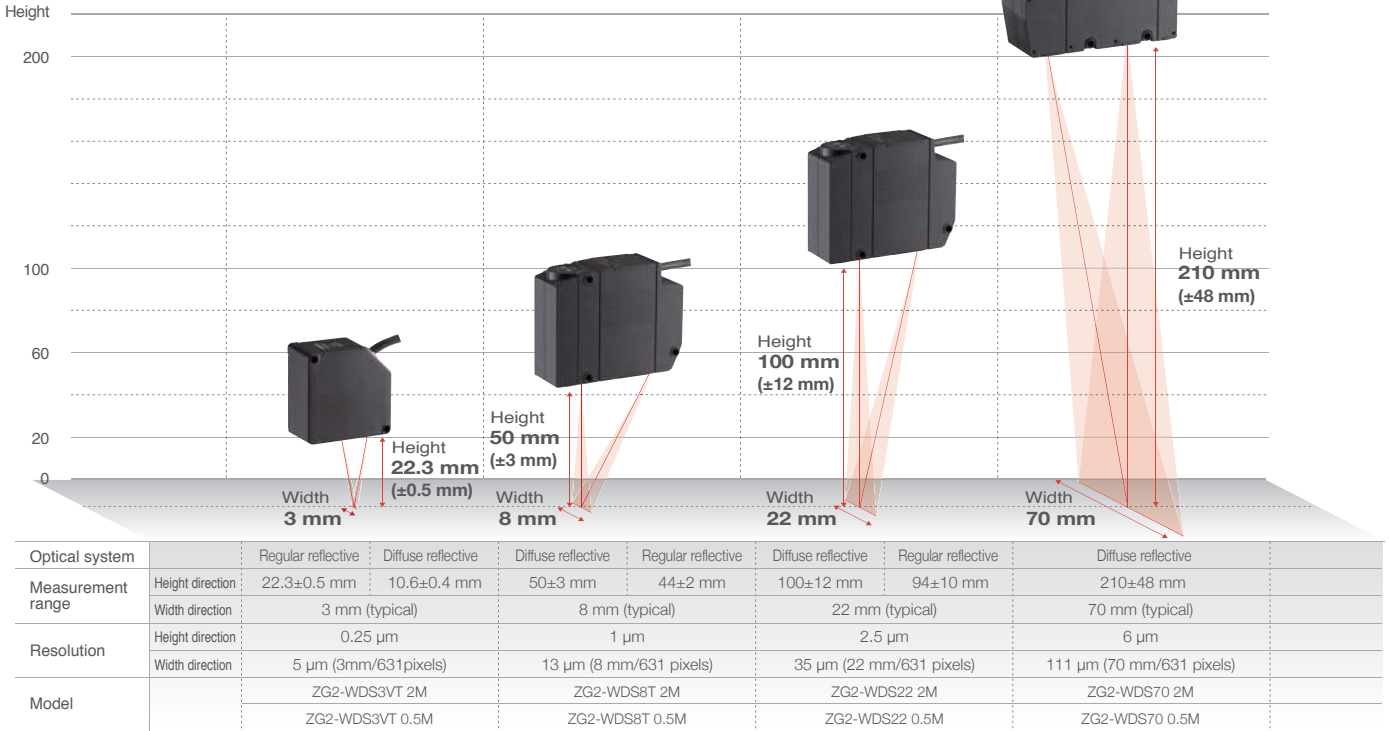

* For details, see the Ratings and Specifications Table.

Sensor Controllers

Note : Setup support software for PC is attached.

Appearance	Power supply	Output type	Model
	24 VDC	NPN	ZG2-WDC11A(See note.)
			ZG2-WDC11
		PNP	ZG2-WDC41A(See note.)
			ZG2-WDC41

Data Storage Unit

Appearance	Power supply	Output type	Model
	24 VDC	NPN	ZG2-DSU11
		PNP	ZG2-DSU41

Accessories (Order Separately)

Real-time Parallel Output Unit

Appearance	Output type	Model
	NPN	ZG-RPD11-N
	PNP	ZG-RPD41-N

RS-232C Cable

Connecting device	Model	Qty
For PLC/PT connection (2 m)	ZS-XPT3	1
For personal computer connection (2 m)	ZS-XRS3	1

Controller Link Unit

Appearance	Model
	ZS-XCN

Sensor Head Extension Cable (Robot Cable)

Appearance	Cable length	Model	Qty
	25 m	ZG2-XC25CR	1
	15 m	ZG2-XC15CR	1
	8 m	ZG2-XC8CR	1
	3 m	ZG2-XC3CR	1

Parallel Mounting Adaptor

Appearance	Model
	ZS-XPM1 For 1 Unit
	ZS-XPM2 For 2 Units or more

Memory Card

Capacity	Model
256 MB	HMC-EF283
512 MB	HMC-EF583

Ratings and Specifications

Sensor Heads

Item		ZG2-WDS8T		ZG2-WDS22		ZG2-WDS70	ZG2-WDS3VT		
Optical system		Diffuse reflective	Regular reflective	Diffuse reflective	Regular reflective	Diffuse reflective	Regular reflective	Diffuse reflective	
Measurement range	Height direction	50 ± 3 mm	44 ± 2 mm	100 ± 12 mm	94 ± 10 mm	210 ± 48 mm (In the high-precision mode)	22.3 ± 0.5 mm	10.6 ± 0.4 mm	
	Width direction (See note 5.)	8 mm (typical)		22 mm (typical)		70 mm (typical)	3 mm (typical)		
Resolution	Height direction (See note 1.)	1 μm		2.5 μm		6 μm	0.25 μm		
	Width direction	13 μm (8 mm / 631 pixels)		35 μm (22 mm / 631 pixels)		111 μm (70 mm / 631 pixels)	5 μm (3 mm / 631 pixels)		
Linearity (in the height direction) (See note 2.)		± 0.1 %F.S.							
Temperature characteristic (See note 3.)		0.03 %F.S./°C			0.02 %F.S./°C		0.08 %F.S./°C		
Light source	Type	Visible semiconductor laser							
	Wavelength	658 nm					650 nm		
	Output	5 mW max. output, 1 mW max. exposure (without using optical instruments)							
	Laser class	Class 2M of EN60825-1 / IEC60825-1 Class IIIB of FDA (21CFR 1040.10 and 1040.11)					Class 2 of EN60825-1 / IEC60825-1 Class II of FDA (21CFR 1040.10 and 1040.11)		
Beam shape (at measurement center distance) (See note 4.)		30 μm × 24 mm (typical)		60 μm × 45 mm (typical)		120 μm × 75 mm (typical)	25 μm × 4 mm (typical)		
LED		STANDBY : Lights when laser irradiation preparation is complete (indication color : green) LD_ON : Lights when the laser is irradiating (indication color : green)							
Measurement object		Surface of non-transparent / transparent objects				Surface of non-transparent objects	Surface of non-transparent / transparent objects		
Environmental resistance	Ambient light intensity	Illumination on the photo-receiving face 7,000 lx max. : Incandescent lamp							
	Ambient temperature	Operating : 0 to 50°C, Storage : -15 to 60°C(with no icing or condensation)							
	Ambient humidity	Operating and storage : 35 to 85 % (with no condensation)							
	Degree of protection (See note 6.)	IP66(IEC60529)					IP67(IEC60529)		
	Vibration resistance (destruction)	10 to 150 Hz with 0.35 mm single amplitude for 80 min each in X, Y, and Z directions							
	Shock resistance (destruction)	150 m/s ² , 3 times each in 6 directions (up / down, right / left, forward / backward)							
Materials		Case: Aluminum diecast, Front cover : Glass, Cable insulation : Heat-resistive polyvinyl chloride (PVC), Connector : Zinc alloy or brass							
Cable length		0.5 m, 2 m (flexible cable)							
Minimum bending radius		68 mm							
Weight		Approx. 500 g		Approx. 500 g		Approx. 650 g	Approx. 300 g		
Accessories		Laser labels (English labels), Ferrite core (2), Instruction manual							

Note : 1. Obtained by setting an OMRON standard measurement object at the measurement center distance and determining the average height of the beam line.
The conditions are given in the table below. However, satisfactory resolution cannot be attained in strong electromagnetic fields.
The minimum resolution of the ZG2-WDS8T/WDS3VT is 0.25 μm, even when the average number of operations is increased. Resolution does not go any lower.

Model	CCD mode	Average No. of operations	Measurement object	
			Regular reflective	Diffuse reflective
ZG2-WDS8T/ZG2-WDS22/ZG2-WDS70	High-resolution mode	64	OMRON standard white alumina ceramic object	
ZG2-WDS3VT			OMRON standard mirrored object	OMRON standard diffuse reflective object

Note : 2. The tolerance for and ideal straight line obtained by determining the average height of and OMRON standard measurement object for the beam line.
The CCD high-resolution mode is used. Linearity varies depending on the measurement object.

Model	CCD mode	Average No. of operations	Measurement object	
			Regular reflective	Diffuse reflective
ZG2-WDS8T/ZG2-WDS22/ZG2-WDS70	High-resolution mode	1	OMRON standard white alumina ceramic object	
ZG2-WDS3VT			OMRON standard mirrored object	OMRON standard diffuse reflective object

Note : 3. A value attained by using an aluminum jig to secure the distance between the Sensor Head and the measurement object. The CCD standard mode is used.

Note : 4. Defined as 1/e² (13.5%) of the center light intensity.

This may be influenced when light leakage also exists outside the defined area and the reflectivity of the light around the measurement object is higher than that of the measurement object.

Note : 5. A typical value of the measurement range (width direction) near the measurement center distance.

This is not a guaranteed value.

Note : 6. Protection structure of connector area is IP40.

Sensor Controllers

Item		ZG2-WDC11/WDC11A	ZG2-WDC41/WDC41A	
Input/output type		NPN	PNP	
No. of connectable Sensor Heads		1 per Controller		
No. of connectable Controllers		2		
Measurement cycle (See note 1.)		16 ms (high-precision mode), 8 ms (standard mode), 5 ms (high-speed mode)		
Min. display unit		10 nm		
Display range		-999.99999 to 999.99999		
Display	LCD monitor	2.2-inch TFT color LCD (557 x 234 pixels)		
	LEDs	<ul style="list-style-type: none"> Judgment indicators for each task (indication color : orange): T1, T2, T3, T4 Laser indicator (indication color : green): LD_ON Zero reset indicator (indication color : green): ZERO Trigger indicators (indication color : green): TRIG 		
External interface	Input/output signal lines	Analog outputs	Select voltage or current (using the sliding switch on the bottom surface) <ul style="list-style-type: none"> Voltage output : -10 to 10 V, output impedance : 40 Ω Current output : 4 to 20 mA, maximum load resistance : 300 Ω 	
		Judgment output (ALL-PASS/NG/ERROR)	NPN open collector 30 VDC, 50 mA max. Residual voltage : 1.2 V max.	
		Trigger auxiliary output (ENABLE/GATE)	PNP open collector 50 mA max. Residual voltage : 1.2 V max.	
		Laser stop input (LD-OFF)	ON : 0 V short or 1.5 V max.	
		Zero reset input (ZERO)	ON : Power supply voltage short or power supply voltage -1.5 V max.	
		Measurement trigger input (TRIG)	OFF : Open (leakage current : 0.1 mA max.)	
	Serial I/O	USB2.0	1 port, full speed (12 Mbps), MINI-B	
		RS-232C	1 port, 115,200 bps max.	
	Parallel output (when ZS-RPD is mounted)	Output	18 - terminal	
Main functions	No. of setting banks	16		
	Sensitivity adjustment	Multi, High-speed multi, Auto, Fixed		
	Measurement items	Height, 2-point Step, 3-point Step, Edge position, Edge width, Angle, Intersection coordinates, Intersection angle, Sectional area, Calculations between tasks (up to eight items can be measured simultaneously)		
	Auxiliary functions	Filter, Laser power adjustment, Position correction (height, position, slope), Linked operation, Point of inflection measurement		
	Profiles saved	16 profiles (1 profile per bank)		
	Trigger modes	External trigger / continuous		
Ratings	Power supply voltage	21.6 to 26.4 VDC (including ripple current)		
	Current consumption	0.8 A max. (per sensor head)		
	Insulation resistance	20 MΩ at 250 V between lead wires and Controller case		
	Dielectric strength	1,000 VAC, 50 / 60 Hz for 1 min between lead wires and Controller case		
Environmental resistance	Ambient temperature	Operating : 0 to 50°C, Storage : -15 to 60°C (with no icing or condensation)		
	Ambient humidity	Operating and storage : 35 to 85 % (with no condensation)		
	Degree of protection	IP20(IEC60529)		
	Vibration resistance (destruction)	Vibration frequency : 10 to 150 Hz, single amplitude : 0.35 mm, acceleration : 50 m/s ²		
	Shock resistance (destruction)	150 m/s ² , 3 times each in 6 directions (up / down, right / left, forward / backward)		
Material	Case : Polycarbonate (PC), Cable insulation : Heat-resistive polyvinyl chloride (PCV)			
Cable length	2 m			
Minimum bending radius	57 mm			
Weight	Approx. 300 g (including cable)(Packed state: Approx. 450 g)			
Accessories	ZG2-WDC_1 : Large Ferrite Core (1 piece), Insure Lock (1 piece), Instruction Manual ZG2-WDC_1A : Large Ferrite Core (1 piece), Small Ferrite Core(2 pieces), Insure Lock (1 piece), Instruction Manual, Smart Monitor ZG2 (exclusive PC software, CD-ROM) (See note 2.), USB cable			

Note : 1. The measurement cycles stated here are values for FIXED/AUTO sensitivity modes. The measurement cycle increases when the MULTI sensitivity/high-speed MULTI sensitivity mode is selected and according to other settings. When the high power mode is set to ON, the shortest measurement cycle becomes 95 ms regardless of the CCD mode setting. Also, when gang-mounting Controllers and Data Storage Units, the measurement cycle increases approximately 22 ms. The actual measurement cycle can be checked by the ECO monitor in RUN mode.

Data Storage Unit

Item		ZG2-DSU11	ZG2-DSU41
Input/output type		NPN	PNP
No. of connectable Controllers		2 (See note 1.)	
Connectable Controllers		ZG2-WDC11/WDC41	
External interface	Input/output signal lines	Inputting starting/terminating logging	ON : 0 V short or 1.5 V max. OFF : Open (leakage current : 0.1 mA max.)
		Judgment output (HIGH/PASS/LOW/ERROR)	NPN open collector 30 VDC, 50 mA max. Residual voltage : 1.2 V max.
	Serial I/O	USB2.0	1 port, full speed (12 Mbps), MINI-B
		RS-232C	1 port, 115,200 bps max.
Functions	No. of logged data (See note 2.)	Memory of the main unit	Profiles saved : 5,120 profiles Measurement values saved : 65,000 values max. (See note 3.)
		Memory card(256 MB) (See note 4.)	Profiles saved : 35,328 profiles max. (256 profiles x 138 files) Measurement values saved : 7,150,000 values max. (65,000 values x 110 files)
		Logging trigger functions	External triggers, data triggers (self-triggers), and time triggers
		External banks functions	4096
		Other functions	Alarm output functions
Ratings	Power supply voltage	21.6 to 26.4 VDC (including ripple current)	
	Current consumption	0.5 A max.	
Environmental resistance	Ambient temperature	Operating : 0 to 50°C, Storage: 0 to 60°C (with no icing or condensation)	
	Ambient humidity	Operating and storage : 35 to 85% (with no condensation)	
Degree of protection		IP20(IEC60529)	
Material		Case : Polycarbonate (PC)	
Cable length		2 m	
Minimum bending radius		52 mm	
Weight		Approx. 280 g	
Accessories		Ferrite Core (1 piece), Instruction Manual	

Note : 1. The controller link unit is necessary for linking.
Note : 2. Data is saved in the memory of the main unit during logging. The data is automatically saved in a memory card after logging is completed. The maximum number of logging differs according to set conditions. For details, refer to the Users Manual.
Note : 3. Measurement values for 65,000 measurements can be saved even when two sensor controllers are connected and each performs eight tasks.
Note : 4. The value is the maximum number achieved in the following conditions.

- One sensor controller performs one measurement task.
- Either profiles or measurement values are logged.

Note : 2. SmartMonitor ZG2
System Requirements
OS: Windows 10 (32-bit/64-bit version)
Windows 7 (32-bit/64-bit version)
Windows XP (Service Pack3 or higher, 32-bit version)
CPU: Intel Pentium III 1 GHz or faster (2 GHz min. recommended.)
Memory: 1 GB min.
Display screen: 1,024 x 768 dots min., 16 million colors min.
- Window is registered trademarks of Microsoft Corporation in the USA and other countries.
- Other company names and product names in this document are the trademarks or registered trademarks or their respective companies.

Dimensions

Sensor Heads

ZG2-WDS3VT

<Regular reflection>

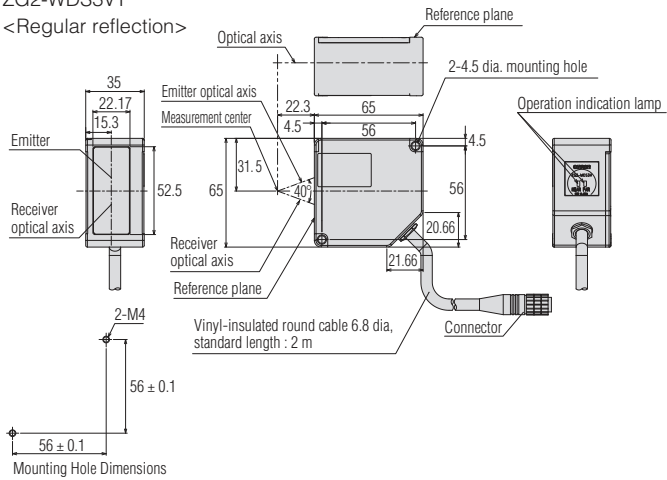

(Unit : mm)

<Diffuse reflective>

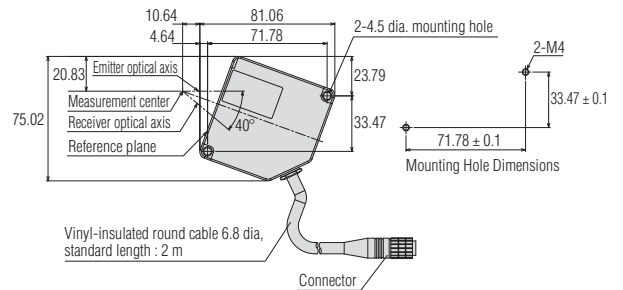

(Unit : mm)

Sensor Heads

ZG2-WDS8T/WDS22

<Diffuse reflective>

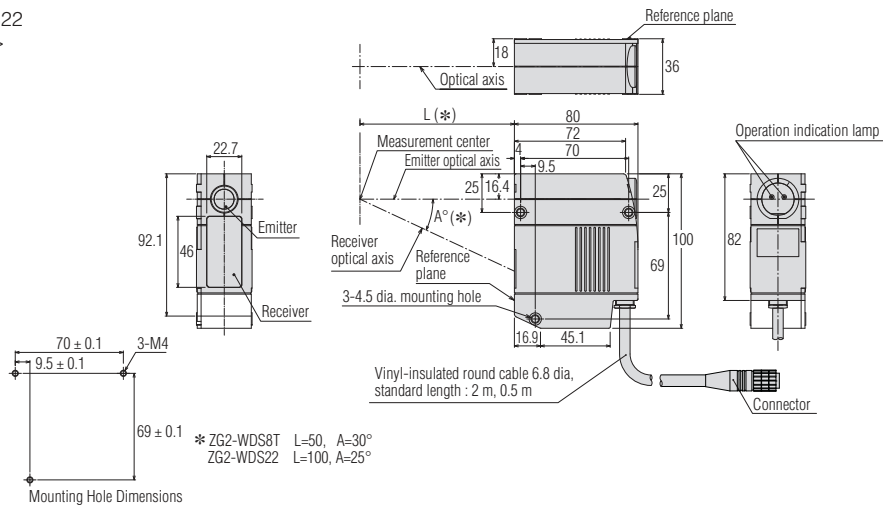

(Unit : mm)

Sensor Heads

ZG2-WDS8T

<Regular reflection>

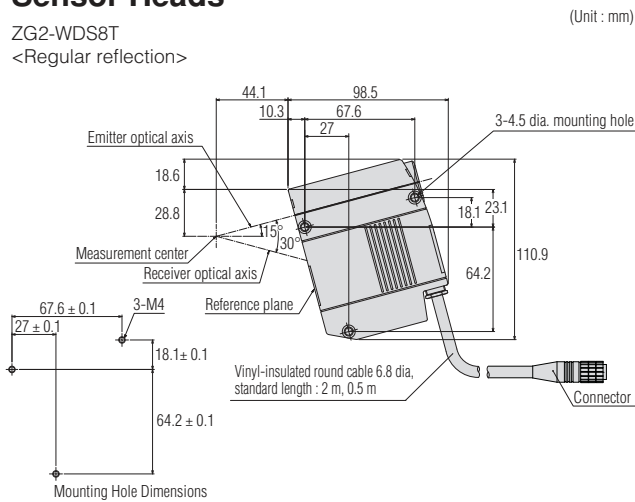

(Unit : mm)

ZG2-WDS22

<Regular reflection>

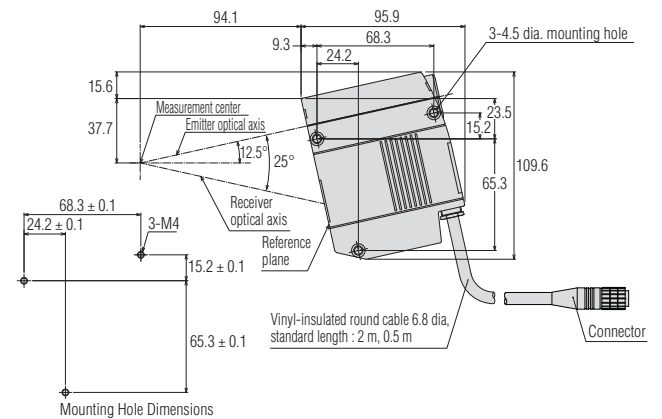

(Unit : mm)

Sensor Heads

ZG2-WDS70
<Diffuse reflective>

(Unit : mm)

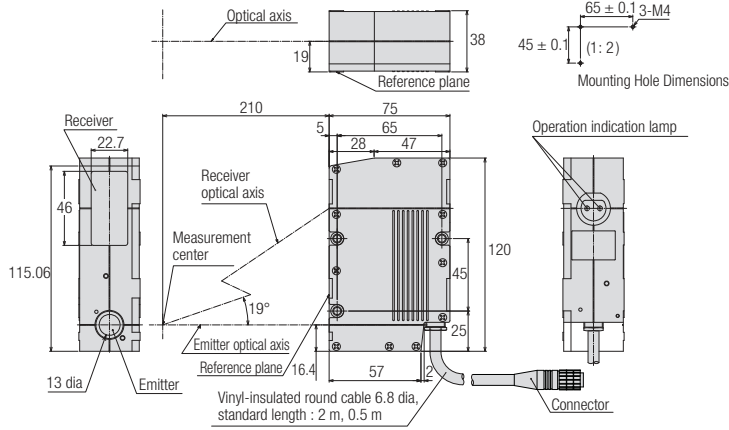

Sensor Controller

ZG2-WDC11/WDC41

(Unit : mm)

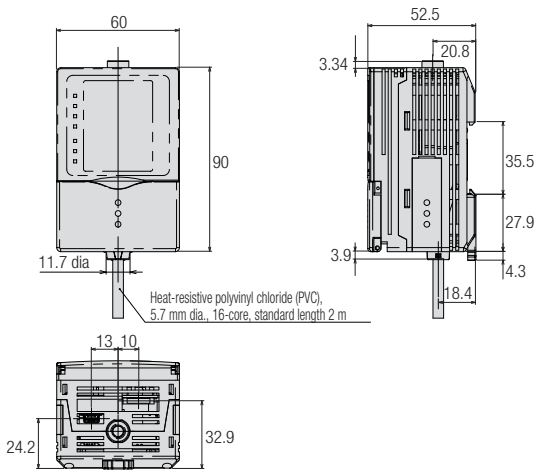

Data Storage Unit

ZG2-DSU11/DSU41

(Unit : mm)

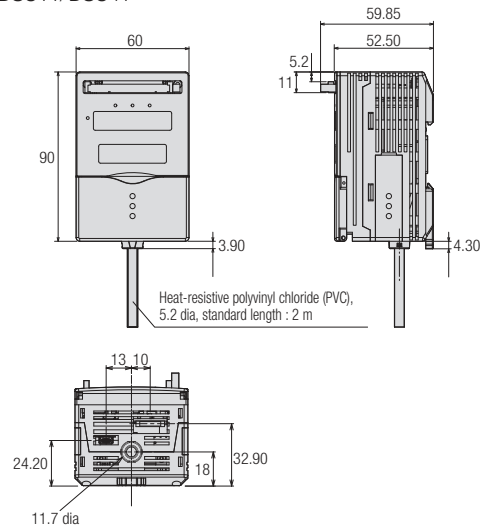

Panel Mounting Adaptor

ZS-XPM1/XPM2 (Dimensions for mounting on a control panel)

(Unit : mm)

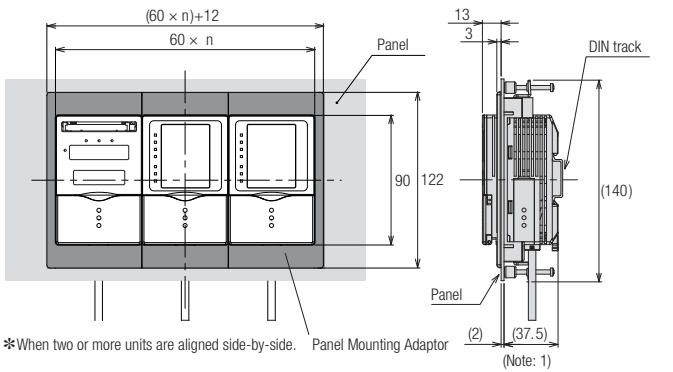

*When two or more units are aligned side-by-side. Panel Mounting Adaptor

Panel cutout dimensions

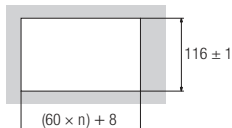

Note: 1. Dimensions are for a 2.0 mm thick panel.

Real-time Parallel Output Unit

ZG-RPD11-N/RPD41-N

(Unit : mm)

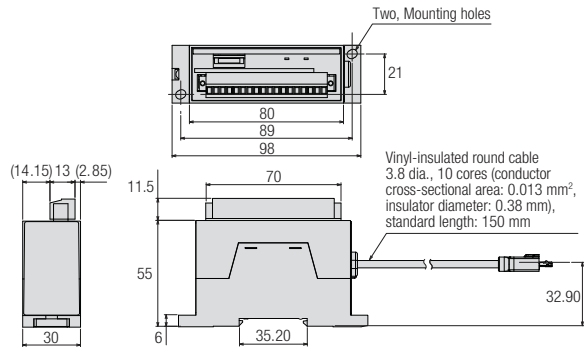

Terms and Conditions Agreement

Read and understand this catalog.

Please read and understand this catalog before purchasing the products. Please consult your OMRON representative if you have any questions or comments.

Warranties.

- (a) Exclusive Warranty. Omron's exclusive warranty is that the Products will be free from defects in materials and workmanship for a period of twelve months from the date of sale by Omron (or such other period expressed in writing by Omron). Omron disclaims all other warranties, express or implied.
- (b) Limitations. OMRON MAKES NO WARRANTY OR REPRESENTATION, EXPRESS OR IMPLIED, ABOUT NON-INFRINGEMENT, MERCHANTABILITY OR FITNESS FOR A PARTICULAR PURPOSE OF THE PRODUCTS. BUYER ACKNOWLEDGES THAT IT ALONE HAS DETERMINED THAT THE PRODUCTS WILL SUITABLY MEET THE REQUIREMENTS OF THEIR INTENDED USE.

Omron further disclaims all warranties and responsibility of any type for claims or expenses based on infringement by the Products or otherwise of any intellectual property right. (c) Buyer Remedy. Omron's sole obligation hereunder shall be, at Omron's election, to (i) replace (in the form originally shipped with Buyer responsible for labor charges for removal or replacement thereof) the non-complying Product, (ii) repair the non-complying Product, or (iii) repay or credit Buyer an amount equal to the purchase price of the non-complying Product; provided that in no event shall Omron be responsible for warranty, repair, indemnity or any other claims or expenses regarding the Products unless Omron's analysis confirms that the Products were properly handled, stored, installed and maintained and not subject to contamination, abuse, misuse or inappropriate modification. Return of any Products by Buyer must be approved in writing by Omron before shipment. Omron Companies shall not be liable for the suitability or unsuitability or the results from the use of Products in combination with any electrical or electronic components, circuits, system assemblies or any other materials or substances or environments. Any advice, recommendations or information given orally or in writing, are not to be construed as an amendment or addition to the above warranty.

See <http://www.omron.com/global/> or contact your Omron representative for published information.

Limitation on Liability; Etc.

OMRON COMPANIES SHALL NOT BE LIABLE FOR SPECIAL, INDIRECT, INCIDENTAL, OR CONSEQUENTIAL DAMAGES, LOSS OF PROFITS OR PRODUCTION OR COMMERCIAL LOSS IN ANY WAY CONNECTED WITH THE PRODUCTS, WHETHER SUCH CLAIM IS BASED IN CONTRACT, WARRANTY, NEGLIGENCE OR STRICT LIABILITY.

Further, in no event shall liability of Omron Companies exceed the individual price of the Product on which liability is asserted.

Suitability of Use.

Omron Companies shall not be responsible for conformity with any standards, codes or regulations which apply to the combination of the Product in the Buyer's application or use of the Product. At Buyer's request, Omron will provide applicable third party certification documents identifying ratings and limitations of use which apply to the Product. This information by itself is not sufficient for a complete determination of the suitability of the Product in combination with the end product, machine, system, or other application or use. Buyer shall be solely responsible for determining appropriateness of the particular Product with respect to Buyer's application, product or system. Buyer shall take application responsibility in all cases.

NEVER USE THE PRODUCT FOR AN APPLICATION INVOLVING SERIOUS RISK TO LIFE OR PROPERTY OR IN LARGE QUANTITIES WITHOUT ENSURING THAT THE SYSTEM AS A WHOLE HAS BEEN DESIGNED TO ADDRESS THE RISKS, AND THAT THE OMRON PRODUCT(S) IS PROPERLY RATED AND INSTALLED FOR THE INTENDED USE WITHIN THE OVERALL EQUIPMENT OR SYSTEM.

Programmable Products.

Omron Companies shall not be responsible for the user's programming of a programmable Product, or any consequence thereof.

Performance Data.

Data presented in Omron Company websites, catalogs and other materials is provided as a guide for the user in determining suitability and does not constitute a warranty. It may represent the result of Omron's test conditions, and the user must correlate it to actual application requirements. Actual performance is subject to the Omron's Warranty and Limitations of Liability.

Change in Specifications.

Product specifications and accessories may be changed at any time based on improvements and other reasons. It is our practice to change part numbers when published ratings or features are changed, or when significant construction changes are made. However, some specifications of the Product may be changed without any notice. When in doubt, special part numbers may be assigned to fix or establish key specifications for your application. Please consult with your Omron's representative at any time to confirm actual specifications of purchased Product.

Errors and Omissions.

Information presented by Omron Companies has been checked and is believed to be accurate; however, no responsibility is assumed for clerical, typographical or proofreading errors or omissions.

Safety Precautions for Laser Equipment

WARNING

Do not expose your eyes to laser radiation either directly or reflected from a mirrored surface. The emitted laser beams have a high power density and direct exposure may result in loss of eyesight.

The warning and explanatory label on the side of the Sensor Head in the ZG2 Series is in Japanese. Replace it with the English label that comes with the product.

Class2

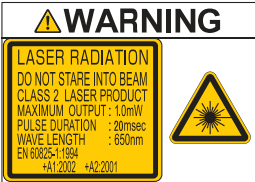

WARNING

LASER RADIATION
DO NOT STARE INTO BEAM
CLASS 2 LASER PRODUCT
MAXIMUM OUTPUT: 10mW
PULSE DURATION : 20msec
WAVE LENGTH : 650nm
EN 60825-1:1994
+A1:2002 +A2:2001

Class2M



WARNING

LASER RADIATION
DO NOT STARE INTO THE BEAM OR VIEW DIRECTLY WITH OPTICAL INSTRUMENTS (MAGNIFIERS)
CLASS 2M LASER PRODUCT
MAXIMUM OUTPUT: 50mW
MAXIMUM PULSE DURATION: 100msec
PULSE DURATION: 15msec
WAVE LENGTH: 650nm
VECTULUM SEMICONDUCTOR LASER
EN 60825-1:1994 +A2:2001 +A1:2002

This document provides information mainly for selecting suitable models. Please read the User's Manual carefully for information that the user must understand and accept before purchase, including information on warranty, limitations of liability, and precautions.

Note: Do not use this document to operate the Unit.

OMRON Corporation Industrial Automation Company
Tokyo, JAPAN

Contact: www.ia.omron.com

Regional Headquarters

OMRON EUROPE B.V.
Sensor Business Unit
Carl-Benz-Str. 4, D-71154 Nufringen, Germany
Tel: (49) 7032-811-0/Fax: (49) 7032-811-199

OMRON ELECTRONICS LLC
One Commerce Drive Schaumburg,
IL 60173-5302 U.S.A.
Tel: (1) 847-843-7900/Fax: (1) 847-843-7787

OMRON ASIA PACIFIC PTE. LTD.
No. 438A Alexandra Road # 05-05/08 (Lobby 2),
Alexandra Technopark,
Singapore 119967
Tel: (65) 6835-3011/Fax: (65) 6835-2711

OMRON (CHINA) CO., LTD.
Room 2211, Bank of China Tower,
200 Yin Cheng Zhong Road,
PuDong New Area, Shanghai, 200120, China
Tel: (86) 21-5037-2222/Fax: (86) 21-5037-2200

Authorized Distributor:

© OMRON Corporation 2008 All Rights Reserved.
In the interest of product improvement,
specifications are subject to change without notice.

CSM_6_6_0518
Cat. No. Q167-E1-01A

Printed in Japan
1208-1M(0109)(AS)