

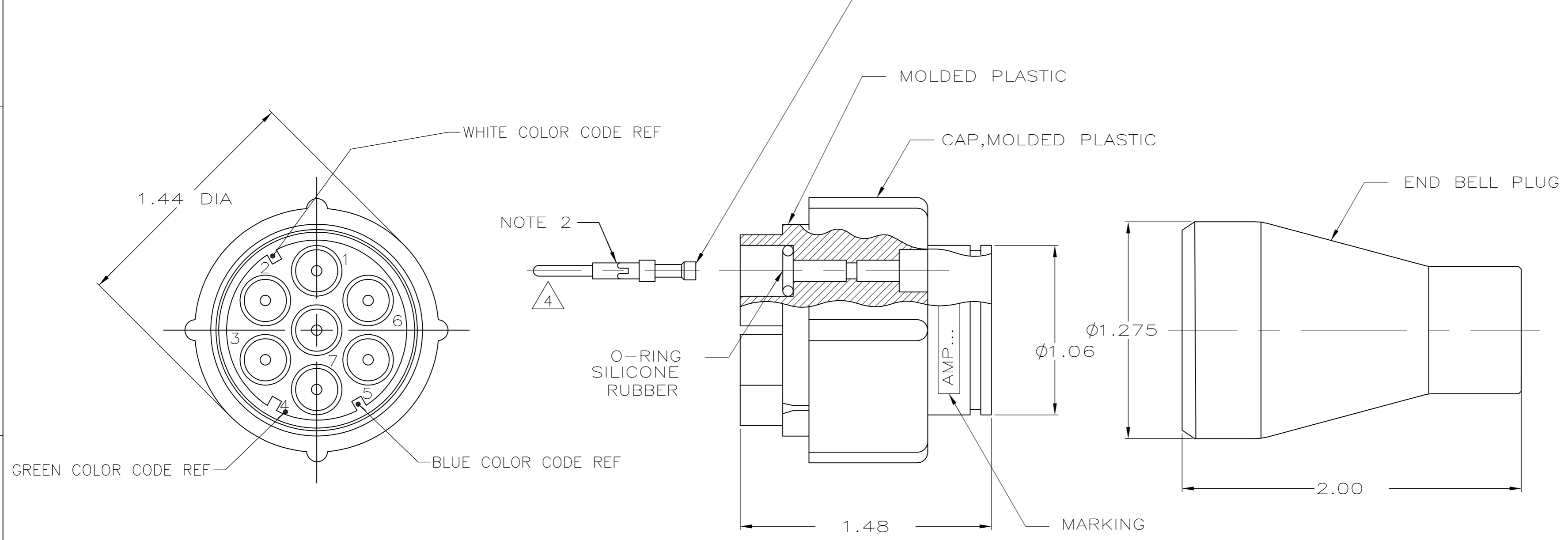

THIS DRAWING IS UNPUBLISHED.		RELEASED FOR PUBLICATION		
© COPYRIGHT - By -		ALL RIGHTS RESERVED.		
PART NO.	WIRE SIZE RANGE	COLOR CODE	REMARKS 	
863024-1	20,22,24	NO	200679-1	
863024-2	16,18	NO	200681-1	
863024-3	14	NO	201645-1	
863024-5	20,22,24	YES	-	OBSOLETE
863024-6	16,18	YES	200681-1	
863024-7	14	YES	-	OBSOLETE
863024-8	-	YES	NO PINS OR O-RINGS	

LOC	DIST	REVISIONS					
-	-	P	LTR	DESCRIPTION	DATE	DWN	APVD
		F		REV PER ECO-15-013197	13OCT15	KG	DM



1. PLUG ASSEMBLY WILL WITHSTAND WITHOUT BREAKDOWN 27KVDC PIN TO PIN AND 27KVDC PIN TO GROUND. WHEN MATED WITH RECEPTACLE 861647-1.
 2. TO REMOVE PINS USE EXTRACTION TOOL #861751-1.
 3. CAVITY TO ACCEPT AMP PINS TYPE II SIZE 16.
-  CRIMP CONTACTS PER TE 408-7516 AS SPECIFIED FOR EACH CONTACT PART NUMBER.

THIS DRAWING IS A CONTROLLED DOCUMENT.		DWN	J.E.BEATTY	25JAN00	 TE Connectivity																		
DIMENSIONS: INCHES		CHK	D.G.EABY	25JAN00																			
TOLERANCES UNLESS OTHERWISE SPECIFIED:		APVD	D.G.EABY	25JAN00																			
<table border="0"> <tr><td>0 PLC</td><td>±</td><td>-</td></tr> <tr><td>1 PLC</td><td>±</td><td>-</td></tr> <tr><td>2 PLC</td><td>±</td><td>.04</td></tr> <tr><td>3 PLC</td><td>±</td><td>.015</td></tr> <tr><td>4 PLC</td><td>±</td><td>-</td></tr> <tr><td>ANGLES</td><td>±</td><td>-</td></tr> </table>		0 PLC	±	-		1 PLC	±	-	2 PLC	±	.04	3 PLC	±	.015	4 PLC	±	-	ANGLES	±	-	PRODUCT SPEC	NAME	
0 PLC	±	-																					
1 PLC	±	-																					
2 PLC	±	.04																					
3 PLC	±	.015																					
4 PLC	±	-																					
ANGLES	±	-																					
MATERIAL	FINISH	WEIGHT	SIZE		CAGE CODE	DRAWING NO	RESTRICTED TO																
-	BLACK	-	A2		00779	C=863024	-																
CUSTOMER DRAWING			SCALE	2:1	SHEET	1 OF 1	REV																
							F																

863024